

SSU-2000e Synchronization Supply Unit and the SDU-2000e Synchronization Distribution Unit

User's Guide
Revision E.01 – January 2007
Part Number 12713140-002-2

Symmetricom, Inc.
2300 Orchard Parkway
San Jose, CA 95131-1017
U.S.A.

<http://www.symmetricom.com>

Copyright © 1999–2007 Symmetricom, Inc.
All rights reserved. Printed in U.S.A.

All product names, service marks, trademarks, and registered trademarks
used in this document are the property of their respective owners.

Contents

How to Use This Guide

Purpose of This Guide	14
Who Should Read This Guide	14
Structure of This Guide	15
Conventions Used in This Guide	15
Warnings, Cautions, Recommendations, and Notes	16
Related Documents and Information	17
Where to Find Answers to Product and Document Questions.	18
What's New in this Guide	18

Chapter 1 Product Overview

Overview	20
Typical System Configurations.	21
Timing Signal Generator (TSG) Configuration	22
Primary Reference Source (PRS) Configuration.	22
SSU-2000e Configured as a Monitor-Only System.	23
System Architecture	23
Input Section	24
Output Section.	27
Clock Section	28
Communications Section.	28
Alarms and Events	29
System Components	31
SSU-2000e Main Shelf (Chassis)	31
SSU-2000e Family of Modules	40
Clock and Communications Modules	41
Input Modules	42
Output Modules.	43
Communications Protocol	44
Software Interface	44
Software Versions	45
Basic System Load	46
Graphical User Interface	46
Overview of SSU-2000e Operation	47
Synchronization Status Messages (SSMs).	47
Indicators and Controls	47
SDU-2000e Synchronization Distribution Unit	48
Functional Overview	50
Expansion Shelf Features	51
Setting the Expansion Shelf Address	53
Buffered Clocks.	53

SDU Module Features	53
Connector Panel Features	54
Controls and Indicators	56

Chapter 2 Installing the SSU-2000e

Unpacking and Inspecting the Shelf	58
Preliminary Procedures	58
Installation Tools and Materials	59
Electromagnetic Interference (EMI) Considerations	59
Ventilation Considerations	60
Rack Mounting the SSU-2000e	60
Making Ground and Power Connections	62
Making Ground Connections	62
Making Power Connections	62
Making Communications Connections	63
Making EIA-232 Serial Port Connections	64
Changing Communications Settings	65
Making Ethernet Connections	65
Making Communications Module Connections	66
Making Signal Connections	67
Making Input Connections	67
Making Output Connections	70
Terminating SDU-2000e Interface Connections	70
Making Alarm Connections	71
Connecting Antennas	73
Handling Modules	73
Installing a Module	75
Exchanging a Module	75
Disabling a Module	76
Removing Modules	77
Installing the SDU-2000e	78
Rack Mounting the SDU-2000e	78
Making Ground Connections	79
Making Power Connections	79
Connecting the Main Shelf	80
Setting the Shelf Address	81
Connecting SDU Clock Outputs	82
Installing SDU Modules	83
Installation Checklist	84
SSU-2000e Turn-Up Procedures	85
SDU-2000e Turn-Up Procedures	86
SDU-2000e Power Control	86
Normal System Indications During Turn-Up	87
After Turn-Up	87

Chapter 3 Provisioning and Operating the SSU-2000e

Controls and Indicators	90
SSU-2000e Status LED Indicators	90
SSU-2000e Operating Controls.	90
Establishing a Connection With the SSU-2000e	90
Communicating by Serial Port.	91
Communicating by Ethernet	92
Overview of the SSU-2000e Security System	93
Adding An Administrator User	95
Adding Users	96
Setting Security Parameters	98
Logging In to the SSU-2000e	102
Logging In with an Expired Password	103
Logging Off of the SSU-2000e	105
Initial Provisioning	105
Provisioning General Parameters	105
Adding or Enabling a Module	106
Disabling a Module	107
Removing a Module	107
Provisioning GPS Input Modules.	108
Provisioning Other Input Modules	109
Provisioning Output Modules	111
Saving the Provisioning Setup	112
Checking Alarm Status.	113
Factory Default (Basic) Configuration	113
Retrieving Factory Defaults	113
Changing Factory Defaults	114
Restoring Factory Defaults	114
Customizing Other Configuration Options.	114
Retrieving the User Configuration	115
Backing Up and Restoring Configurations	115
Backing Up the Configuration	116
Using ICS Commands.	116
Restoring the Configuration	116
Using ICS Commands.	117

Chapter 4 Commissioning the SSU-2000e

Readiness to Test Checklist.	120
Equipment Requirements.	121
Commissioning Tests.	121
Testing the Ethernet Communications Interface	121
Testing the EIA-232 Ports	122
Testing The Minor Alarms	122
Testing the Major Alarms	123

Testing the Critical Alarms	123
Testing the Reference Signals and Selection	124
Testing the Clock Section	124
Testing the Output Section	125
Testing the System Stability and Accuracy (Optional)	125
Commissioning Test Data Sheet	126
Commissioning the SDU 2000e	126
Readiness to Test Checklist	127
Equipment Requirements	127
Commissioning Tests	128
Commissioning Test Data Sheet	129

Chapter 5 Maintenance and Troubleshooting

Responding to Alarms	132
Preventive Maintenance	132
Corrective Maintenance	133
Troubleshooting	135
Establishing a Connection	135
Troubleshooting Guide	136
Interpreting Status Messages	137
Troubleshooting the SDU-2000e	140
Re-ordering Information	141
Equipment Return Procedure	141
Repacking	141
Contacting Technical Support	142

Chapter 6 Clock and Communications Module Reference Data

Stratum 2E Clock Module	144
Functional Overview	144
Functional Block Diagram	145
Status LED Indicators	146
Functional Specifications	147
Configuration Data	148
Stratum 3E Clock Module	148
Functional Overview	148
Functional Block Diagram	149
Status LED Indicators	150
Performance Specifications	151
Configuration Data	152
Type I Clock Module	152
Functional Overview	152
Functional Block Diagram	153
Status LED Indicators	154
Functional Specifications	155
Configuration Data	155

Communications Module	156
Functional Overview	156
Functional Block Diagram	158
Status LED Indicators	158
Alarm Logic	160
Configuration Data	161
EIA-232 Ports	162
Ethernet Port	162
Resetting the Module	162

Chapter 7 Input Module Reference Data

1-Port and 3-Port E1 Input Modules	164
Functional Overview	164
Functional Block Diagram	164
Status LED Indicators	170
Configuration Settings	172
Software Options	172
1-Port and 3-Port DS1 Input Modules	174
Functional Overview	174
Functional Block Diagram	174
Status LED Indicators	180
Configuration Settings	182
Software Options	182
GPS Input Module	184
GPS Input Module Functional Overview	184
Functional Block Diagram	184
Status LED Indicators	186
Configuration Settings	187
Composite Clock Input Module	188
Functional Overview	188
Functional Block Diagram	189
Status LED Indicators	190
Configuration Settings	191

Chapter 8 Output Module Reference Data

E1 Output Module	194
Functional Overview	194
Functional Block Diagram	195
Status LED Indicators	196
Performance Specifications	197
DS1 Output Module	198
Functional Overview	198
Status LED Indicators	199
Performance Specifications	200
Composite Clock Output Module	201
Composite Clock Output Module Overview	201

Functional Block Diagram	202
Status LED Indicators	203
Performance Specifications.	204
E1/2048 kHz Output Module	205
Functional Overview	205
Provisioning the Signal Type.	205
Output Squelching.	205
Bypass Clock (CLK-C) Alarms	208
Functional Block Diagram	210
Status LED Indicators	211
Performance Specifications.	212
2048 kHz Output Module	213
Functional Overview	213
Output Squelching.	213
Functional Block Diagram	216
Status LED Indicators	217
Performance Specifications.	219
RS-422 Output Module	219
Functional Overview	219
Provisioning Output Frequencies	220
Output Squelching.	220
Functional Block Diagram	223
Status LED Indicators	224
Performance Specifications.	225
Buffer Module.	225
Status LED Indicators	226

Chapter 9 Hardware Configuration Guide

Configuring a Conventional SSU/TSG System	228
Configuring a Primary Reference Source (PRS) System.	228
Configuring a Monitor-Only System	229
Configuring a Subtending SSU	230
Functional Description.	230
Input Section	231
Output Section.	232
Setting Subtending Parameters	233
Changing to Subtending SSU Mode	234
Required Hardware	234
Installing Software.	235
Changing From Subtending SSU Mode	235
SSU-2000e Configuration Chart	236
SDU-2000e Configuration Chart	240

Index	243
------------------------	------------

Figures

1-1	SSU-2000e Synchronization Supply Unit.	20
1-2	SSU-2000e in TSG Configuration	22
1-3	SSU-2000e Configured as a Primary Reference Source.	22
1-4	SSU-2000e Configured as a Monitor Only System	23
1-5	Block Diagram of the SSU-2000e	24
1-6	SSU-2000e Module Chassis Slot Assignments	32
1-7	SSU-2000e Upper Front Panel Connections	33
1-8	Clock Input Connector Groups	34
1-9	SSU-2000e Input Connector Scheme	35
1-10	SSU-2000e Power Connections	38
1-11	Serial Port Connector Pins	39
1-12	SDU-2000e Synchronization Distribution Unit	48
1-13	SDU-2000e Block Diagram	50
1-14	SDU-2000e Expansion Chassis Components	52
1-15	Backup Clock Terminator, Side and Front Views	53
1-16	SDU-2000e Connection Features	55
1-17	Expansion Chassis Cabling	56
2-1	Equipment Mounting Cabinet.	62
2-2	SSU-2000e Power Input Connector.	63
2-3	DE9 Connector Detail.	64
2-4	Serial Port DTE/DCE Switch	65
2-5	Communications Module Serial Connection	66
2-6	Clock Input Connector Pinout	68
2-7	Non-Payload E1 and DS1 Input Termination	68
2-8	Through Payload E1 and DS1 Input Termination.	69
2-9	Clock Output Connector Pinout	70
2-10	SSU Expansion Terminator (J8).	71
2-11	SSU Backup Clock Terminator (J9) Side and Front View	71
2-12	Alarm Contact Closures and Pin Assignments.	72
2-13	Equipment Mounting Cabinet.	80
2-14	SSU-2000e Expansion Terminator.	81
2-15	Backup Clock Terminator, Side and Front View.	81
2-16	Shelf Address Selector.	82
3-1	Direct Connection Using the Serial Port.	91
5-1	Alarm and Event Status Breakdown.	137
6-1	Block Diagram of the Stratum 2E Clock Module	145
6-2	Front Panel of the Stratum 2E Clock Module.	146
6-3	Block Diagram of the Stratum 3E Clock Module	149
6-4	Front Panel of the Stratum 3E Clock Module.	150
6-5	Block Diagram of the Type I Clock Module	153
6-6	Front Panel of the Type I Clock Module	154
6-7	Block Diagram of the Communications Module	158
6-8	Front Panel of the Communications Module	159

7-1	Block Diagram of the 1-Port and 3-Port E1 Input Modules	165
7-2	Front Panel of the E1 Input Module	171
7-3	Block Diagram of the 1-Port and 3-Port DS1 Input Module	175
7-4	Front Panel of the DS1 Input Module	181
7-5	Block Diagram of the GPS Input Module	185
7-6	Front Panel of the GPS Input Module	186
7-7	Block Diagram of the Composite Clock Input Module	189
7-8	Front Panel of the Composite Clock Input Module	190
8-1	Block Diagram of the E1 Output Module	195
8-2	Front Panel of the E1 Output Module	196
8-3	Block Diagram of the DS1 Output Module	198
8-4	Front Panel of the DS1 Output Module	199
8-5	Block Diagram of the Composite Clock Output Module	202
8-6	Front Panel of the Composite Clock Output Module	203
8-7	Using the Hex Number to Identify Output Ports	207
8-8	Block Diagram of the E1/2048 kHz Output Module	210
8-9	Front Panel of the E1/2048 kHz Output Module	211
8-10	Using the Hex Number to Identify Output Ports	214
8-11	Block Diagram of the 2048 kHz Output Module	217
8-12	Front Panel of the 2048 kHz Output Module	218
8-13	Using the Hex Number to Identify Output Ports	221
8-14	Block Diagram of the RS-422 Output Module	223
8-15	Front Panel of the RS-422 Output Module	224
8-16	Front Panel of the Buffer Module	226
9-1	Timing Sync Generator (TSG) System Configuration	228
9-2	SSU-2000e Configured as PRS System	229
9-3	SSU-2000e Configured as Monitor-Only System	229
9-4	SSU-2000e Main Shelf, Front View	236
9-5	SDU-2000e Expansion Shelf, Front View	240

Tables

1-1	Module Slot Locations	31
1-2	Clock Input Connector to Input Module Relationship	34
1-3	Clock Output Connector to Output Module Relationship	36
1-4	Local and Remote Alarm Connector Pin Assignments	37
1-5	Serial Port Connector Pin Assignments	39
1-6	Ethernet Connector Pinouts	40
1-7	Communications Module Software Versions	46
1-8	Expansion Shelf Addressing	53
2-1	Communications Port Assignments	64
2-2	Ethernet Connector (J3) Pinouts	66
2-3	Communication Requirements for Control Input and Output	67
2-4	Input Module Slot to Connector Relationship	69
2-5	Output Module Slot to Connector Relationship	70
2-6	Alarm Contact Pin Assignments	72
2-7	Module Slot Addresses in the Main Shelf	73
2-8	Clock Output DE9 Connector Pin Assignments	82
2-9	Output Module Slot to Connector Relationship	83
2-10	Module Slot Addresses	83
2-11	Power LED Indications	85
3-1	Communications Port Assignments	90
3-2	Firmware Requirements for Security Features	94
3-3	User Access Levels	95
4-1	SSU-2000e Readiness Checklist	120
4-2	Commissioning Test Data Sheet - SSU	126
4-3	SDU-2000e Readiness Checklist	127
4-4	Commissioning Test Data Sheet - SDU	129
5-1	SSU Corrective Action Table	134
5-2	SDU Corrective Action Table	134
5-3	SSU-2000e Troubleshooting Procedures	138
5-4	SDU-2000e Troubleshooting Procedures	140
6-1	Stratum 2E Clock Module Status LED Indicators	146
6-2	Stratum 2E Clock Module Specifications	147
6-3	Stratum 2E Clock Module Options/Defaults	148
6-4	Stratum 3E Clock Module Status LED Indicators	150
6-5	Stratum 3E Clock Module Performance Specifications	151
6-6	Stratum 3E Clock Default Values and Ranges	152
6-7	Type I Clock Module Status LED Indicators	154
6-8	Type I Clock Module Specifications	155
6-9	Type I Clock Module Options/Defaults	156
6-10	Communications Module Status LED Indicators	159
6-11	Communications Module Alarms	161
6-12	Communications Module Configuration Data	161

7-1	E1 Input Module Alarm Modes	167
7-2	E1 Input Module Event Reporting	170
7-3	E1 Input Module Status LED Indicators	171
7-4	E1 Input Module Configuration	172
7-5	DS1 Input Module Alarm Modes	177
7-6	DS1 Input Module Event Reporting	180
7-7	DS1 Input Module Status LED Indicators	181
7-8	DS1 Input Module Configuration	182
7-9	GPS Input Module Status LED Indicators	186
7-10	GPS Input Module Configuration Settings	187
7-11	Composite Clock Input Module Status LED Indicators	190
7-12	Composite Clock Input Module Configuration Settings	191
8-1	E1 Output Module Status LED Indicators	196
8-2	E1 Output Module Performance Specifications	197
8-3	DS1 Output Module Status LED Indicators	200
8-4	DS1 Output Module Performance Specifications	200
8-5	Composite Clock Output Module Status LED Indicators	203
8-6	Composite Clock Output Module Performance Specifications	204
8-7	Identifying Failed Ports from the Hex Digit	207
8-8	E1/2048 kHz Output Module Status LED Indicators	211
8-9	E1/2048 kHz Output Module Specifications	212
8-10	Identifying Failed Ports from the Hex Digit	215
8-11	2048 kHz Output Module Status LED Indicators	218
8-12	2048 kHz Output Module Specifications	219
8-13	Identifying Failed Ports from the Hex Digit	222
8-14	RS-422 Output Module Status LED Indicators	224
8-15	RS-422 Output Module Performance Specifications	225
8-16	Buffer Module Status LED Indicators	226
9-1	Minimum Software Versions for Subtending Operation	234
9-2	Files Required for Upgrading the Firmware	235
9-3	SSU-2000e System Components	237
9-4	SDU-2000e System Components	241

How to Use This Guide

This section describes the format, layout, and purpose of this guide.

In This Preface

- [Purpose of This Guide](#)
- [Who Should Read This Guide](#)
- [Structure of This Guide](#)
- [Conventions Used in This Guide](#)
- [Warnings, Cautions, Recommendations, and Notes](#)
- [Related Documents and Information](#)
- [Where to Find Answers to Product and Document Questions](#)
- [What's New in this Guide](#)

Purpose of This Guide

The *SSU-2000e User's Guide* describes the procedures for unpacking, installing, using, maintaining, and troubleshooting the Symmetricom SSU-2000e Synchronization Supply Unit (SSU-2000e). An accompanying document, the *SSU-2000e Technical Reference* (12713140-003-2) describes default alarms and events, the languages you use to communicate with the SSU-2000e, default values, and other information.

Who Should Read This Guide

[Chapter 1, Product Overview](#), is written for non-technical audiences who need general information about the product. [Chapter 2, Installing the SSU-2000e](#), and subsequent chapters contain technical information about the product. Other chapters describe installation, maintenance, and configuration instructions or details primarily intended for qualified maintenance personnel.

This *User's Guide* is designed for the following categories of users:

- **Systems Engineers** – [Chapter 1](#) provides an overview of the SSU-2000e. Cross-references in this chapter direct you to detailed system information in other chapters as appropriate.
- **Installation Engineers** – [Chapter 2](#) through [Chapter 9](#) provide detailed information and procedures to ensure proper installation, turn-up, operation, configuration, and testing of the SSU-2000e.
- **Maintenance Engineers** – [Chapter 5](#) provides preventive and corrective maintenance guidelines, as well as procedures for diagnosing and troubleshooting fault indications and alarms.

While [Chapter 1](#) is written for non-technical audiences who need information about the SSU-2000e system, others, such as [Chapter 2](#) through [Chapter 9](#) contain detailed information and instructions which are intended to be performed by *qualified personnel only*.

Structure of This Guide

This guide contains the following sections:

Chapter, Title	Description
Chapter 1, Product Overview	Provides an overview of the product, describes the major hardware and software features, and lists the system specifications.
Chapter 2, Installing the SSU-2000e	Contains procedures for unpacking and installing the product, and for powering up the unit.
Chapter 3, Provisioning and Operating the SSU-2000e	Describes the ICS and TL1 commands required to provision the SSU-2000e after installing the unit.
Chapter 4, Commissioning the SSU-2000e	Provides checklist-based commissioning tests that should be performed after completing turn-up and software configuration to ensure the system is ready for normal operation.
Chapter 5, Maintenance and Troubleshooting	Contains preventive and corrective maintenance, and troubleshooting procedures for the product.
Chapter 6, Clock and Communications Module Reference Data	Provides detailed information on the Communications module and the various Clock modules available for use in the SSU-2000e.
Chapter 7, Input Module Reference Data	Contains detailed information on the Input modules available for use in the SSU-2000e.
Chapter 8, Output Module Reference Data	Describes the Output modules available for use in the SSU-2000e and in the SDU-2000e.
Chapter 9, Hardware Configuration Guide	Describes how to configure the SSU-2000e in several modes, and lists part number for shelves, modules, and accessories.
Index	Provides references to individual topics within this guide.

Conventions Used in This Guide

This guide uses the following conventions:

- **Acronyms and Abbreviations** – Terms are spelled out the first time they appear in text. Thereafter, only the acronym or abbreviation is used.
- **Revision Control** – The title page lists the printing date and versions of the product this guide describes.
- **Typographical Conventions** – This guide uses the typographical conventions described in the table below.

When text appears this way...	... it means:
<i>SSU-2000e User's Guide</i>	The title of a document.
SSU CRITICAL	An operating mode, alarm state, status, or chassis label.
Select File , Open...	Click the Open option on the File menu.
Press Enter Press ;	A named keyboard key. The key name is shown as it appears on the keyboard. An explanation of the key's acronym or function immediately follows the first reference to the key, if required.
SSU Username :	Text in a source file or a system prompt or other text that appears on a screen.
PING STATUS	A command you enter at a system prompt or text you enter in response to a program prompt. You must enter commands for case-sensitive operating systems exactly as shown.
<i>A re-timing application</i>	A word or term being emphasized.
Symmetricon does not recommend...	A word or term given special emphasis.

Warnings, Cautions, Recommendations, and Notes

Warnings, Cautions, Recommendations, and Notes attract attention to essential or critical information in this guide. The types of information included in each are explained in the following examples.



Warning: To avoid serious personal injury or death, *do not* disregard warnings. All warnings use this symbol. Warnings are installation, operation, or maintenance procedures, practices, or statements, that if not strictly observed, may result in serious personal injury or even death.



Caution: To avoid personal injury, *do not* disregard cautions. All cautions use this symbol. Cautions are installation, operation, or maintenance procedures, practices, conditions, or statements, that if not strictly observed, may result in damage to, or destruction of, the equipment. Cautions are also used to indicate a long-term health hazard.



ESD Caution: To avoid personal injury and electrostatic discharge (ESD) damage to equipment, *do not* disregard ESD cautions. All ESD cautions use this symbol. ESD cautions are installation, operation, or maintenance procedures, practices, conditions, or statements that if not strictly observed, may result in possible personal injury, electrostatic discharge damage to, or destruction of, static-sensitive components of the equipment.



Electrical Shock Caution: To avoid electrical shock and possible personal injury, do not disregard electrical shock cautions. All electrical shock cautions use this symbol. Electrical shock cautions are practices, procedures, or statements, that if not strictly observed, may result in possible personal injury, electrical shock damage to, or destruction of components of the equipment.



Recommendation: All recommendations use this symbol. Recommendations indicate manufacturer-tested methods or known functionality. Recommendations contain installation, operation, or maintenance procedures, practices, conditions, or statements, that provide important information for optimum performance results.



Note: All notes use this symbol. Notes contain installation, operation, or maintenance procedures, practices, conditions, or statements, that alert you to important information, which may make your task easier or increase your understanding.

Related Documents and Information

Other helpful documents and software tools are listed below. See your Symmetricom representative or sales office for a complete list of available documentation.

- *SSU-2000e Technical Reference* (12713140-003-2)
- SynCraft management software
- TimePictra management software



Note: Symmetricom offers training courses designed to enhance your knowledge of the SSU-2000e. Contact your local representative or sales office for a complete list of courses and outlines.

Where to Find Answers to Product and Document Questions

For additional information about the products described in this guide, please contact your Symmetricom representative or your local sales office. You can also contact us on the web at www.symmetricom.com.

What's New in this Guide

Revision E.01 of this guide contains the following new information:

- Added two new sections: [Retrieving Factory Defaults](#), on page 113, and [Retrieving the User Configuration](#), on page 115.
- Removed the tables in [Synchronization Status Messages \(SSMs\)](#), on page 47 and added a reference to ITU-T G.781.
- Added CC Input Module to Module Replacement section in [Table 5-1](#).
- Added [Configuring a Subtending SSU](#), on page 230.

Chapter 1 Product Overview

This chapter describes the SSU-2000e and provides a theory of operation for the unit. The SDU-2000e expansion shelf is also introduced and described.

In This Chapter

- [Overview](#)
- [Typical System Configurations](#)
- [System Architecture](#)
- [System Components](#)
- [Communications Protocol](#)
- [Overview of SSU-2000e Operation](#)
- [Indicators and Controls](#)
- [SDU-2000e Synchronization Distribution Unit](#)

Overview

The SSU-2000e Synchronization Supply Unit, shown in [Figure 1-1](#), provides a Stratum 1 network synchronization solution for central office (CO), end office, customer premises equipment (CPE) sites, controlled equipment vaults (CEV) and telecommunications and data communications network operations. The SSU-2000e family of products consists of:

- SSU-2000e Synchronization Supply Unit
- SSU-2000e family of modules
- SDU-2000e Expansion Shelf (up to four units), shown in [Figure 1-12](#)
- Various mounting accessories, cabling accessories and other accessories as described in the SSU-2000e Technical Reference

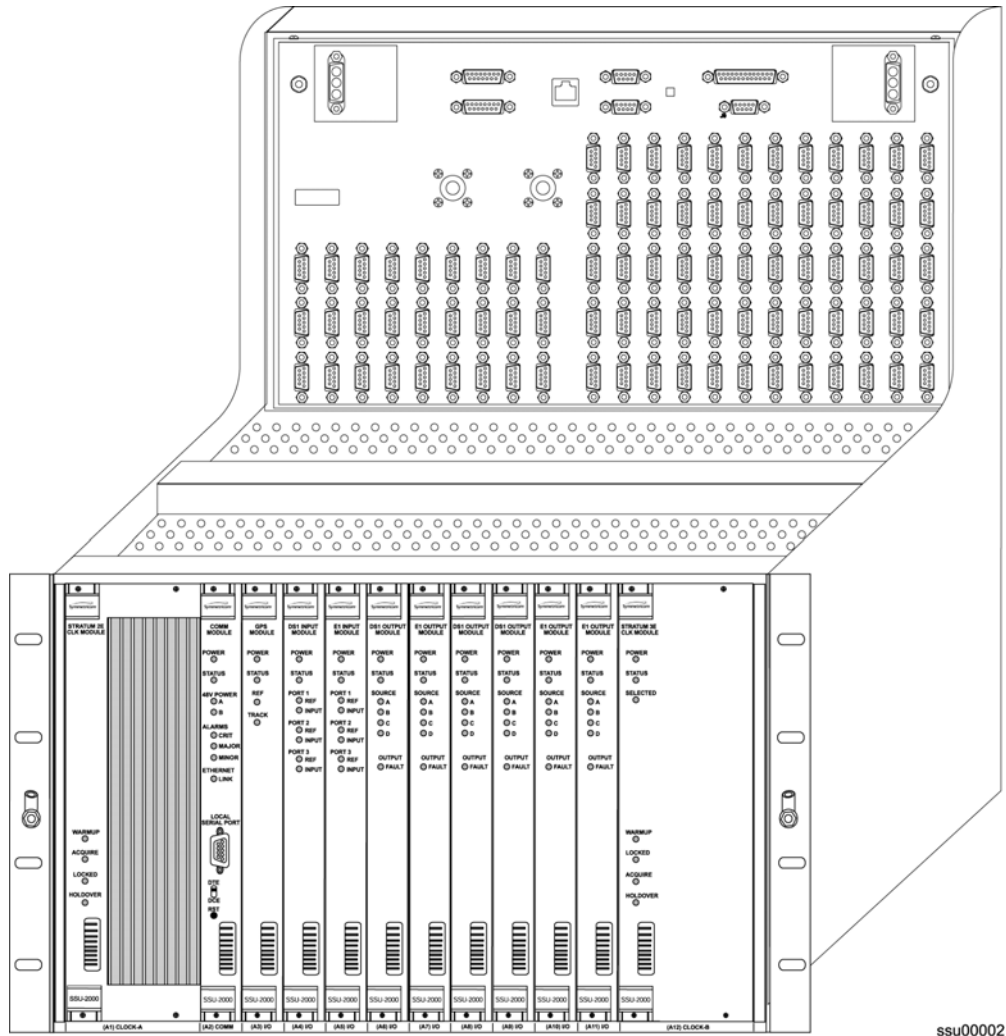

Figure 1-1. SSU-2000e Synchronization Supply Unit

The SSU-2000e Synchronization Supply Unit (SSU-2000e) is a high-performance Synchronization Status Messaging (SSM)-compliant Timing Signal Generator (TSG) or Synchronization Supply Unit (SSU) that provides network synchronization signals for the telephone and telecommunications industry. The SSU-2000e features an integral front-access input/output (I/O) adapter panel for ease of access, connections, and maintenance.

The SSU-2000e conforms to specifications for International, European and North American applications as a Primary Reference Source (PRS), Synchronization Supply Unit, and Timing Signal Generator. The SSU-2000e allows for the integration of a variety of synchronization reference schemes including GPS and land line DS1/E1. As a slave clock, the SSU-2000e meets or exceeds performance requirements outlined in Telcordia Technologies (formerly Bellcore) ITU-T G.812 Stratum 2 and ETSI Type II Transit Node clocks.

The SSU-2000e is designed to comply with the application flexibility and redundancy concepts introduced in Telcordia Technologies GR-2830. A selection of hot-swappable modules and powerful software allow users to easily reconfigure, upgrade, or expand the SSU-2000e to meet a variety of telecommunications synchronization application requirements. The SSU-2000e fully supports Synchronization Status Messaging as defined by ITU, ETSI, and ANSI requirements in accordance with Telcordia Technologies.

The SSU-2000e is fully user-configurable and manageable through the use of a software interface. Modules can be inserted into or removed from the SSU-2000e while the system is operational without any degradation of output signals. Each module supports the local and remote management of critical, major and minor alarms. Output modules and clock modules can be configured in redundant pairs, further increasing system availability.

The SSU-2000e has extensive event detection, reporting, alarming, and storage capabilities that permit monitoring of the system from external sites. Events are defined as changes in conditions within the unit, or at the interfaces of the unit, which may indicate abnormal operation or a change in the unit's operational status. For example, an event may be a parameter which exceeds a settable threshold. Most events can be assigned by the user to one of the following modes: IGNORE, REPORT, MINOR, MAJOR, or CRITICAL.

Typical System Configurations

The modular design of the SSU-2000e permits a great deal of flexibility in configuring the system components for a variety of applications. Three of the more common configurations include:

- Time Signal Generator (TSG) configuration
- Primary Reference Source (PRS) configuration
- Monitor-only configuration

Timing Signal Generator (TSG) Configuration

The Timing Signal Generator (TSG) configuration shown in [Figure 1-2](#) allows for input of external references to which the Clock modules are phase and frequency locked. This configuration allows for monitoring of several inputs, and for synchronization of output signals.

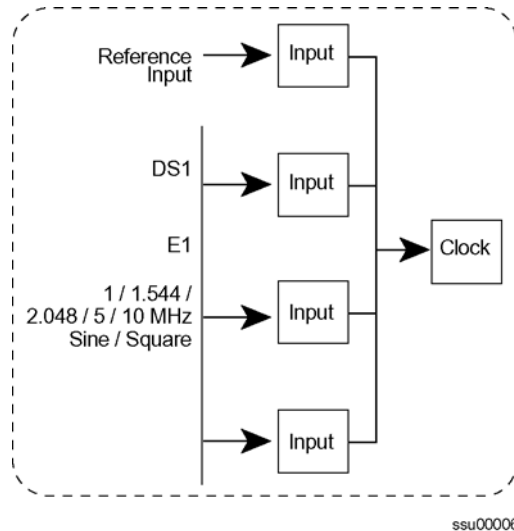

Figure 1-2. SSU-2000e in TSG Configuration

Primary Reference Source (PRS) Configuration

In a Primary Reference Source (PRS) configuration ([Figure 1-3](#)), the SSU-2000e meets the specifications defined for ETSI Type II Transit Node Clocks in American National Standards Institute (ANSI) T1.101-1999. ANSI defines a Primary Reference Source as “equipment that provides a timing signal whose long term accuracy is maintained at 1×10^{-11} or better, with verification to Universal Coordinated Time (UTC), and whose timing signal may be used as the basis of reference for the control of other clocks within a network”. If standard Input modules are installed in the remaining input slots, this configuration also allows for monitoring of up to 24 external signals, such as DS1, E1, Composite Clock, and various clock frequencies. Time-of-day functionality is available through an Ethernet port employing NTP.

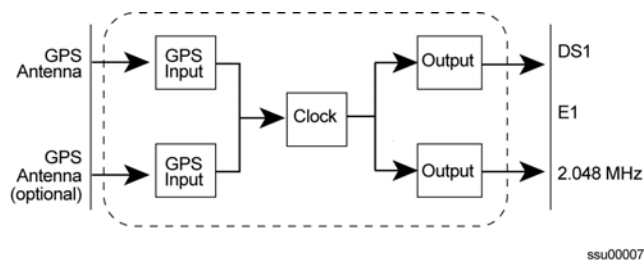

Figure 1-3. SSU-2000e Configured as a Primary Reference Source

SSU-2000e Configured as a Monitor-Only System

The SSU-2000e can also be configured as a monitor-only system (Figure 1-4) in which one of the inputs is designated as the reference, and a clock module is locked directly to this signal. The remaining input signals are then compared to the phase-locked oscillators (and indirectly to the designated input reference).

The SSU-2000e continuously monitors incoming timing signal integrity. The operator defines input acceptance criteria and sets parameters for alarming. If the incoming signal is acceptable (within the performance limits set by the operator), the SSU-2000e phase-locks to the signal on a priority basis.

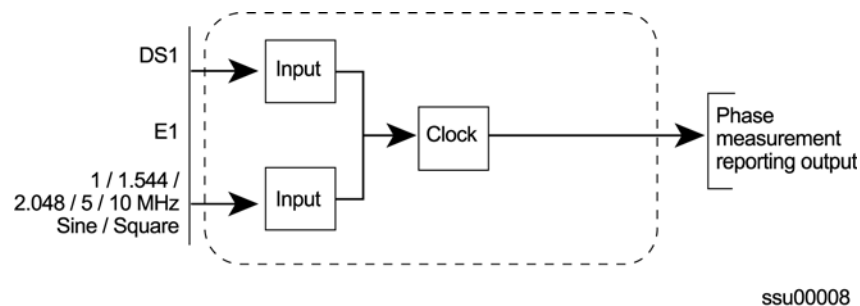

Figure 1-4. SSU-2000e Configured as a Monitor Only System

System Architecture

The SSU-2000e system is a Timing Signal Generator that controls, monitors, generates, and distributes network synchronization signals. The I/O signals can be DS1, E1, Composite Clock (CC), sinusoids, or square waves. The SSU-2000e continuously monitors incoming timing signal integrity. The operator defines input acceptance criteria and sets parameters for alarming. If a reference signal is acceptable (within the performance limits set by an operator), the SSU-2000e frequency-locks to the signal on a priority basis. System holdover and filtering performance is dependent on the quality of oscillators used in the SSU-2000e's internal clock modules (Stratum 2E or Stratum 3E).

A selection of hot-swappable modules and system software allow users to easily configure, upgrade, or expand the SSU-2000e system to meet a variety of telecommunications synchronization application requirements. Modules can be inserted or removed from the SSU-2000e while the system is operational without degradation of output signals. Each module supports the management of critical, major, and minor alarms. Output modules and clock modules can be configured in redundant pairs for increased reliability.

A simplified system block diagram for the SSU-2000e is shown in Figure 1-5.

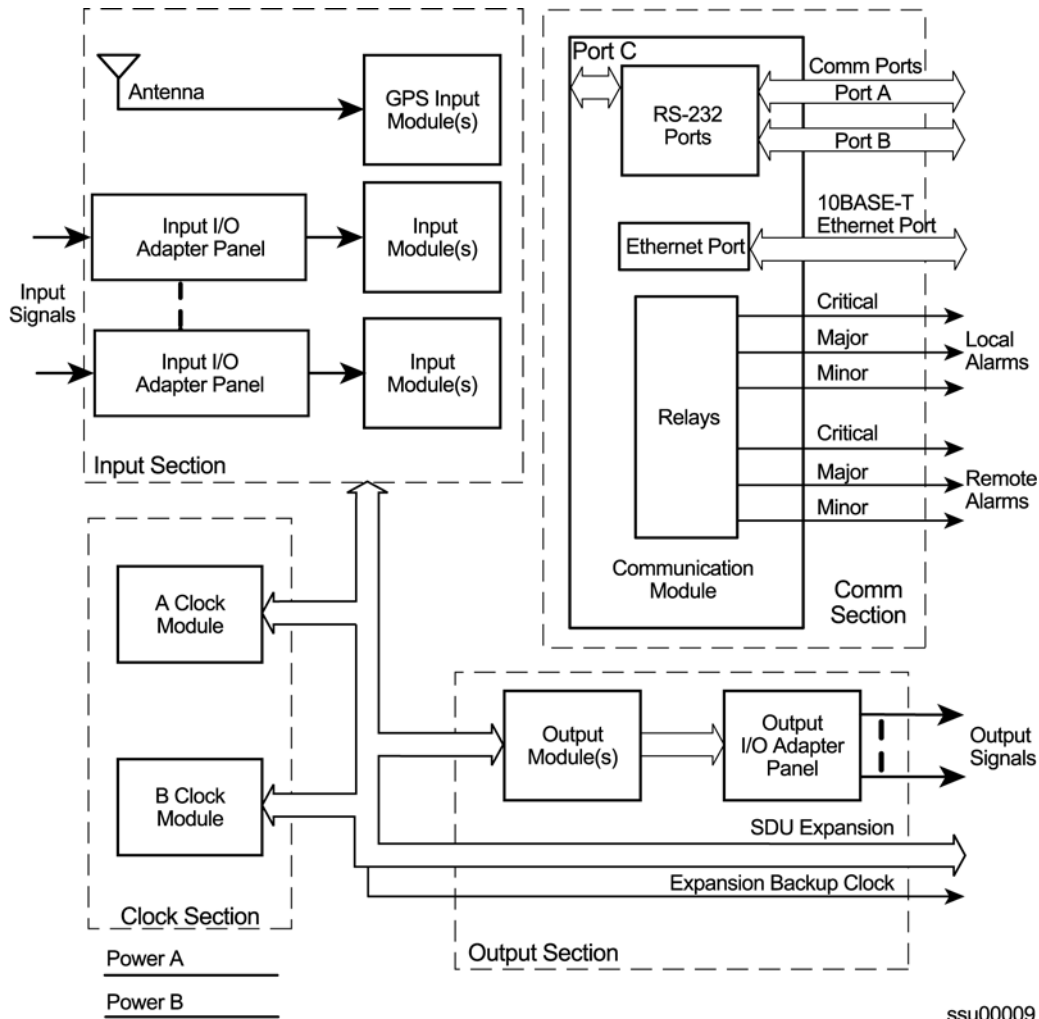

ssu00009

Figure 1-5. Block Diagram of the SSU-2000e

As indicated in [Figure 1-5](#), the SSU-2000e consists of four major sections:

- Input section
- Clock section
- Output section
- Communications section

Input Section

The input section consists of one or more (maximum of three) Input modules that are connected to reference signals and are tested for signal integrity. The Input modules are described in [Chapter 7, Input Module Reference Data](#). You provision each input using the INPUT and REF commands or the SET-PRMTR-INPUT and SET-INPUT-REF commands.

The Input modules make phase measurements between the input signal and the clock oscillator(s). From these phase measurements, the Input modules compute frequency offset and wander of the input signals. Wander is reported in terms of Maximum Time Interval Error (MTIE) and Time Deviation (TDEV). The data is then stored for use in the SSU-2000e and reported through the Communications module. You can install one or two GPS input modules that use the satellite-based Global Positioning System signals as a synchronization reference. The input signal types supported are:

- DS1/Clock (unframed)
- E1/Clock (unframed)
- GPS
- Composite Clock

Selecting the Input

Many factors influence which input reference the SSU-2000e uses:

- Priority
- PQL/SSM
- Switching mode
- User-assigned Input State
- Active alarms on an input

You can provision the SSU-2000e to automatically select the highest-quality input signal, or you can manually select the input signal you want to use. Two factors determine the quality of the input: the user-defined Priority level, and the PQL/SSM. These factors are used to determine which input is used, and what happens if that input becomes disqualified.

Priority Level

You can assign a Priority level to each input; this value helps determine which input is used as the system reference. The range is 0 to 10; the lower the Priority level, the higher the priority. Use the TL1 command SET-PRMTR-INPUT or the ICS command INPUT to provision these parameters. See [Setting the Input Selection Mode](#), on page 26, for details on using the Priority level.

SSMs and Quality Level

Synchronization Status Messages (SSMs) may be included in the bit stream of the incoming signal to indicate its quality level. To read the incoming SSM, you must provision the input to read the SSM; for E1 signals, you must provision the bit position of the incoming SSM. Use the TL1 command SET-PRMTR-INPUT or the ICS command INPUT to provision these parameters.

If the incoming signal does not include SSMs, or if you disable them, then you can provision the Quality Level to an appropriate value. The PQL value is used in the same manner as the incoming SSM to determine which input is used when the active input is disqualified. SSMs are described in more detail in [Synchronization Status Messages \(SSMs\)](#), on page 47.

Setting the Reference Switching Mode

There are two reference selection modes available: Revertive and Non-revertive. In the Revertive mode, if an input used as the system reference is disqualified (for any reason), the reference switches to the next-highest input and reverts to the initial input when that input is re-qualified. In this mode, the reference switches two times: once when the disqualifying event occurs, and again when the initial input is re-qualified. In the Non-revertive mode, the system reference switches to the next-highest input but does not revert to the initial input when the initial input is re-qualified. The system reference switches only once when the disqualifying event occurs.

The ICS command REF and the TL1 command SET-INPUT-REF allows you to set the reference switching mode to AutoReturn, AutoSwitch, or OFF. The AutoReturn mode is Revertive, and enables automatic switching with automatic return to the input with the highest Priority or PQL level. The AutoSwitch mode is Non-revertive; the reference automatically switches to the next-highest input on failure of the selected input. When set to OFF, only manual switching is allowed. If the selected reference input is disqualified for any reason, the clock enters the Holdover mode and you must correct the fault and re-provision the reference input.

Setting the Input Selection Mode

The ICS command REF and the TL1 command SET-INPUT-REF determine what type of reference input selection and reference switching is used. You can set the input selection to either Priority or PQL. The reference switching mode is either Autoreturn, Autoswitch, or No switching.

After you select the reference switching mode, the Input module reads and processes the Priority level and PQL value to determine the traceability of inputs. This traceability information is then used by the Clock modules in selecting a reference signal and for embedding the SSM into the outputs.

If you select *Priority* mode, the SSU-2000e selects the input reference with the highest user-defined Priority setting; if all inputs have the same Priority level, then the input with the highest PQL (quality level, SSM) is used.

If you select *PQL* mode, the SSU-2000e selects the input reference with the highest assigned PQL level or associated SSM; if all inputs have the same PQL/SSM value, then the input with the highest Priority levels is used. In either case, error conditions such as Loss of Signal (LOS), Out of Frame (OOF), MTIE, TDEV, and Phase performance data collected at the inputs are used to disqualify inputs (prevent input selection) based on user defined thresholds.

In either mode, when the Priority and PQL values are equal for each input, the physical location of the Input module determines the priority for selecting the input reference. Port 1 on the Input module in the leftmost slot has the highest priority; the priority decreases to port 1 on the Input module in the rightmost slot. Port 2 on the module in the leftmost slot has the next lower priority, decreasing to Port 2 on the Input module in the rightmost slot. Port 3 on the module in the leftmost slot has the next lower priority, and Port 3 on the module in the rightmost slot has the lowest priority.

If the Input module is configured for provisioned mode, it reports the user-assigned SSM. If it is configured for automatic mode, the Input module uses the most recent valid SSM. If a valid SSM is not received, the module uses the user-assigned SSM.

Setting an Input Alarm Strategy

You can provision the SSU-2000e to elevate input alarms to the next higher level after a specified amount of time. You can also specify that an alarm clears automatically after a specified period of time without the alarm condition. For more information on alarms, see [Alarms and Events](#), on page 29.

Bypass Clock (Clock C)

In the event that both Clock modules fail, an input connected to a DS1, E1, or Composite Clock Input module can serve as the system reference. The input must be a valid reference, and it must have a Priority setting. When the Bypass clock is the active reference, then the output signal is not filtered and any wander or jitter on the input signal appears on the outputs. The Bypass clock is intended only for short-term use; you should resolve the failures on the Clock modules as quickly as possible.

Output Section

The output section is implemented with one or more Output modules (up to 6, in the main chassis and up to 46 Output modules in a fully expanded system with four SDU-2000e expansion chassis). Each Output module type provides 20 independent or 10 paired output synchronization signals. Output modules are available to support the following formats:

- DS1, SF (D4) and ESF
- E1
- 2048 kHz
- Composite Clock (CC) (64/8 kHz)
- Other typical clock frequencies

Clock Section

The clock section consists of one or two Clock modules that provide the internal reference signals for generating TSG output timing signals. The primary Clock module (Clock A) is configured as the master clock and is normally a higher stratum level than the back-up clock (Clock B). If a problem occurs in Clock A, the control is automatically passed to the back-up clock module (Clock B). The frequency of each clock is locked to a valid reference input signal (one that is free from input faults while meeting acceptable frequency and MTIE specifications).

The SSU-2000e controls clock frequency by adjusting the control value of the Direct Digital Synthesis (DDS) function in each Clock module. The adjustments are processor-controlled and based on measurements performed and computed in the input module(s). Internal clock modules may be Stratum 2E, Stratum 3E, and Type I. Outputs are maintained by the active input reference signal if both clocks should ever fail or be removed from the system.

Communications Section

The Communications section consists of one Communications module, which contains hardware and software that allows the user to configure, monitor, and control the SSU-2000e system and generate local and remote alarms when fault conditions are detected. The SSU-2000e can continue to function seamlessly without the Communications module (Clock modules assume the system controller function), but all communications and alarm reporting functions are interrupted.

The master controller function for the SSU-2000e can reside in either the Communications module or in either of the Clock modules. The priority of the selection of the module that will provide the master controller function rests with the Communications module, Clock A, and Clock B, in that order. In the event of removal of the module designated as the master controller, that function automatically and seamlessly switches to the next module in priority order.

The Communications module communicates with the other modules in the SSU-2000e to read configuration data, set operational parameters, and determine what type of modules are installed. When a module is replaced, the controller loads the correct operational parameters into the replacement module.

The Communications module is installed in slot A2 and provides an interface between the user and the SSU-2000e system. This interface allows the user to display and control much of the activity in the SSU-2000e system and within the optional SDU-2000e expansion system. The Communications module supports three serial ports and one Ethernet port, and allows communication over each of them independently in one of several possible modes (ICS, TL1, SNMP, or packet).

The software in the Communications module allows for on-site reprogramming of the flash ROM and all programmable logic devices. The software on all other module types installed in the SSU-2000e system can be updated by downloading it through the Communications module.

When the Communications module is installed, it performs an initial software verification test to verify operation. If the module is being installed in the SSU-2000e with power already applied and with other modules installed, the Communications module reads the configuration of the modules in the SSU-2000e and the modules in all installed SDU-2000e expansion shelves. This information is saved in nonvolatile memory on the Communications module. If power is applied to the SSU-2000e after the Communications module is installed, it initializes before any of the other modules and provides configuration information to the individual modules.



Note: The clock modules also store configuration information and can download this information to the various modules, if the Communications module is not installed in the system.

Alarms and Events

The SSU-2000e has extensive event detection, reporting, and alarm generation and storage capabilities that permit monitoring of the system from external sites.

Alarms are conditions within the unit or at the interfaces of the unit which may indicate abnormal operation or a change in the unit's operational status. For example, an alarm may be generated when a parameter exceeds a user-settable threshold. Most alarms can be assigned by the user to one of the following modes: IGNORE, REPORT, MINOR, MAJOR, or CRITICAL.

All Alarms detected in the SSU-2000e system are reported by three methods, including:

- Display on the module LEDs
- Relay contact closures on the back of the SSU-2000e chassis
- Messages transmitted on all communications ports

All Alarm indications clear when the condition(s) that caused them no longer exist. In a case where a module in alarm is unplugged from the system, the ICS command CONFIG xAy REMOVE clears the module's active alarms. In addition, normal operating status is indicated by green LEDs on the modules.

Events are conditions within the unit, or at the interfaces of the unit, which may indicate abnormal operation or a change in the unit's operational status. Recurring events may be escalated to alarm status and may require action by the user. Conversely, alarms may be de-escalated and corrected automatically. See the *SSU-2000e Technical Reference* for details.

Although every alarm is considered to be an event, not every event is an alarm. For example, a *login* is recorded as an event but is not considered to be an alarm. In this case, no action is required by the user.

Ignore Mode

IGNORE means that appropriate information on the event is transmitted on all of the communications ports when the event occurs, and on demand, but no alarm is generated. For example, the status of the SSM at each input port and at the output ports is reported when it changes and when the user sends an inquiry but no alarm is generated.

Report Mode

The REPORT mode option is used to report alarm indications only.

An ALARM command is available in the SSU-2000e firmware that allows a user to view the current status of alarm indications on the unit and set alarm delay intervals and activation levels. Only active alarm indications are displayed unless an option is specified.

The DELAY option sets the length of time in seconds an alarm must be active before generating a hardware indication. This option also allows the user to set the level of any alarms:

- **IGNORE** – ignore any alarm indication
- **REPORT** – report only alarm indications
- **MINOR** – sets alarm level to MINOR
- **MAJOR** – sets alarm level to MAJOR
- **CRITICAL** – sets alarm level to CRITICAL

See the *SSU-2000e Technical Reference* for details on the DELAY option.

Alarm Mode

The user sets the alarm to one of three levels of alarm severity: MINOR, MAJOR or CRITICAL. In general, events that are classified as ALARMS are those for which user or Craft intervention is required. MINOR and MAJOR alarms can be elevated automatically to the next higher level after a user-settable time period.

For Input Ports to be disqualified as possible system references, the alarm level must be Major (it can elevate from a Minor) or Critical. Additionally, the system can select a redundant component when the currently selected module/component indicates a Major or Critical Alarm, for example a Clock Module Alarm set to Major allows the system to select the Secondary Clock Module.

The unit is capable of generating reports to include: local oscillator being switched, log in/out, restart, board removed/inserted, events cleared, PLL loop control, user image clear/set, phase samples, frequency control, and a keep-alive output every 5 minutes. See the *SSU-2000e Technical Reference* for information on commands.

Alarms and all events are reported over the communication ports and contain details of the event in a single message including the time of the event. All ALARM indications clear when the conditions that caused them no longer exist. In addition, normal operating status is indicated by green LEDs on the front panel of modules.

Fail Mode (Critical)

In the FAIL mode, the SSU-2000e removes the failed module from service or usability to prevent interruption of the system. For example, a FAIL event detected in Clock A causes a switchover from Clock A to Clock B, effectively removing Clock A from the system. The FAIL event is reported on all communications ports and an alarm is generated.

System Components

The fully expanded SSU-2000e system contains the following physical components:

- SSU Main Chassis populated with various combinations of Clock, Input, Output and Communications modules
- Up to four SDU-2000e Expansion shelves containing buffer and output modules



Note: For additional information about each of the module types, see [Chapter 6, Clock and Communications Module Reference Data](#), [Chapter 7, Input Module Reference Data](#), and [Chapter 8, Output Module Reference Data](#). Also see [Chapter 9, Hardware Configuration Guide](#) for component part numbers and guidelines for configuring a new system.

SSU-2000e Main Shelf (Chassis)

The SSU-2000e main shelf (shown in [Figure 1-6](#)) contains a metal chassis and a motherboard with provisions for supporting up to 12 hot-swappable modules. Filler panels are available for use in chassis that are not fully populated.

Module Assignments

All SSU-2000e modules are equipped with card ejectors and plug in from the front of the chassis. Each module is secured in the chassis with captive fasteners. The module assignments for the SSU-2000e main chassis are listed in [Table 1-1](#) and shown in [Figure 1-6](#).

Table 1-1. Module Slot Locations

Slot	Module
A1	Clock Module A
A2	Communications Module

Table 1-1. Module Slot Locations (Continued)

Slot	Module
A3-A5	Input Module
A6-A11	Output Module
A12	Clock Module B

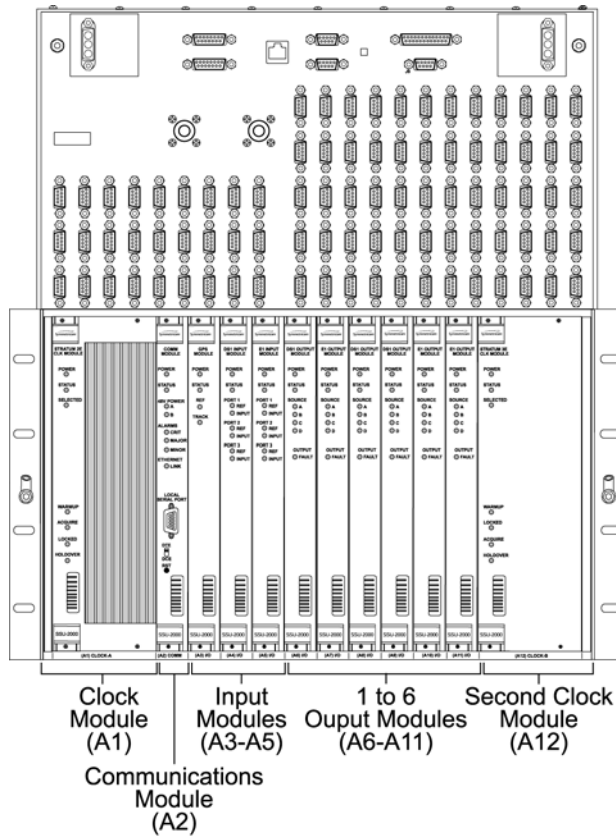

ssu00015

Figure 1-6. SSU-2000e Module Chassis Slot Assignments

As indicated in [Figure 1-6](#), the SSU-2000e modules are assigned slots A1 through A12, numbered left to right as viewed from the front of the chassis. The first or left-most slot, A1, is assigned to the primary Clock module (Clock A). Slot A2 is assigned to the Communications module and slots A3 through A11 are assigned to various combinations of Input modules and Output modules. Slot A12 is reserved for the B Clock module.

Main Shelf Connections

All connections to and from the SSU-2000e are made on the upper front panel of the SSU-2000e main shelf, as shown in [Figure 1-7](#).

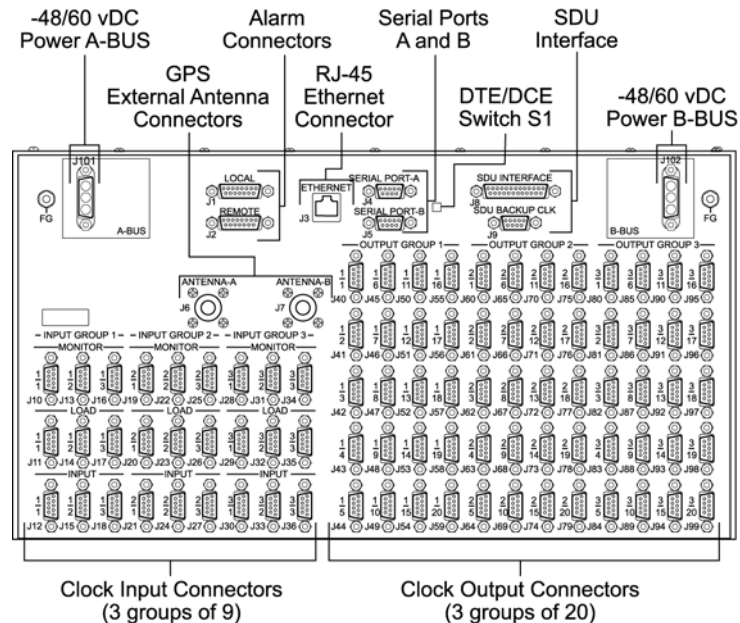

ssu00016

Figure 1-7. SSU-2000e Upper Front Panel Connections

The SSU-2000e main shelf contains the following connection features:

- **Three groups of Clock input connectors** – each group of nine Clock input connectors (9-pin, Micro-D female) is associated with a specific Input module slot.
- **Three groups of 20 output connectors** – each group of 20 outputs connect through internal summing circuits to two Output modules. In the event of the failure of one module, the second module continues supplying output signals. The first module can be electrically disconnected from the output circuitry with relays activated by the software.
- **Dual set of power terminals and dual set of grounding lugs** – for connecting external power and grounding to the SSU-2000e system.
- **Three communications ports** – two serial port connections, Serial Port-A and Serial Port-B, and one RJ-45 ethernet connector (10-base-T). Another serial communication port, Serial Port-C, is available on the front of the Communications module.
- **DTE/DCE switch** – this slide switch (S1) allows the user to select either data terminal equipment (DTE – default, PC connection) or data communication equipment (DCE – modem connection) type of serial port interface for SERIAL PORT-A and SERIAL PORT-B. The right position is labeled A and the left position is labeled B.
- **Local and remote alarm connectors** – each 15-pin Micro-D female connector is electrically connected to the relays on the Communications module.
- **Two antenna connectors** – for attaching radio receiver antennas.

- **SDU-2000e optional interface connector** – up to four expansion shelf can be connected in daisy-chain fashion to an SSU-2000e. A termination plug must be installed on this connector if not using the output signal expansion shelf system.
- **SDU Backup Clock (D-Clock) connector** – supplies a backup clock to any attached expansion shelf.

Clock Input Connectors

The upper half of the SSU-2000e contains three groups of nine Clock input connectors, as shown in Figure 1-8. Each group of nine connectors includes three monitor connectors, three load connectors and three input connectors. Connections for Input Group 1 are made in connectors J10 through J18. Connections for Input Group 2 are made in connectors J19 through J27, and the connections for Input Group 3 are made in connectors J28 through J36.

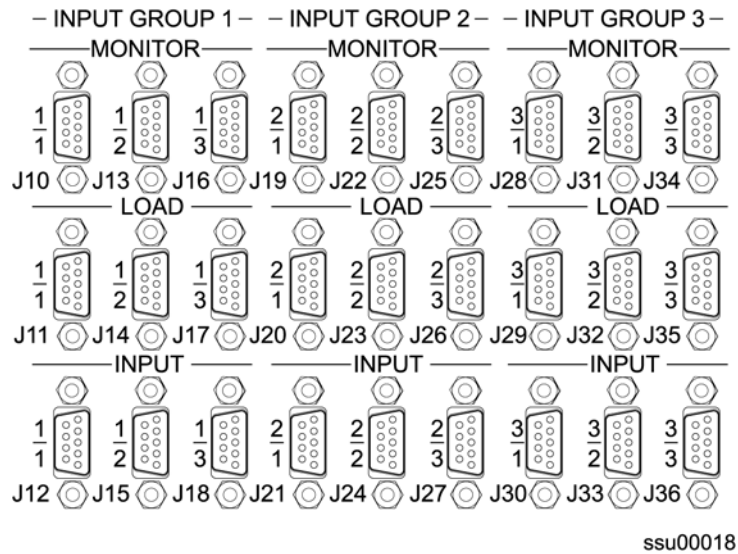

Figure 1-8. Clock Input Connector Groups

The three input groups map directly to the Input modules installed in slots A3 through A5 as listed in Table 1-2.

Table 1-2. Clock Input Connector to Input Module Relationship

Slot Label (Name)	Plug-in Module Slot	Module Input Port	Connector Reference Description		
			Monitor	Load	Input
INPUT-1	A3	1	J10	J11	J12
		2	J13	J14	J15
		3	J16	J17	J18

Table 1-2. Clock Input Connector to Input Module Relationship (Continued)

Slot Label (Name)	Plug-in Module Slot	Module Input Port	Connector Reference Description		
			Monitor	Load	Input
INPUT-2	A4	1	J19	J20	J21
		2	J22	J23	J24
		3	J25	J26	J27
INPUT-3	A5	1	J28	J29	J30
		2	J31	J32	J33
		3	J34	J35	J36

The Load and Input connectors are cross-wired as four wire, east-west connections. The Input connectors are used to connect the clock reference inputs to the associated input ports on the installed Input modules. Termination plugs are available to install in the load connectors if the reference signal is to be terminated.

The Monitor connectors are connected as 20 dB monitors to each attached clock reference input signal, as shown in [Figure 1-9](#).

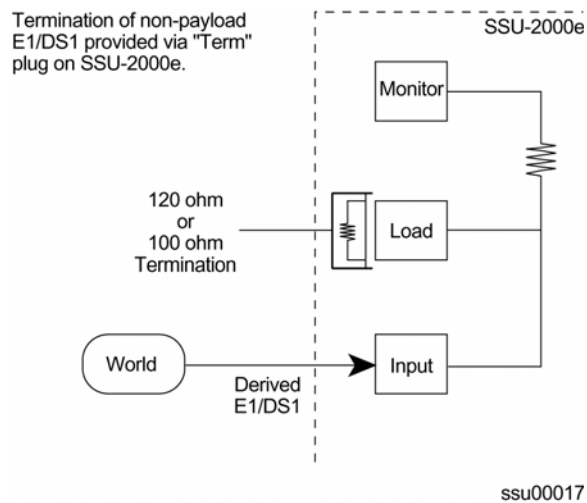

Figure 1-9. SSU-2000e Input Connector Scheme

Output Clock Connectors

The SSU-2000e connector panel contains three groups of 20 summed output clock connectors. The groups are labeled OUTPUT GROUP 1 that are installed in A6 and A7, OUTPUT GROUP 2 that are installed in A8 and A9, and OUTPUT GROUP 3 that are installed in A10 and A11. See [Table 1-3](#) for additional information.

The signal outputs from each pair of Output modules are summed internal to the unit and all outputs are connected to the output connectors through software-controlled relays in the Output modules. If one of a redundant pair of Clock modules fails, the software can electrically disconnect the faulty module without interrupting the clock outputs.

Table 1-3. Clock Output Connector to Output Module Relationship

Slot Label (Name)	Plug-in Module Slot	Group	Output Connector (Module Port) Reference Description
OUTPUT-1	A6	1	J40 (1) through J59 (20)
OUTPUT-2	A7		
OUTPUT-3	A8	2	J60 (1) through J79 (20)
OUTPUT-4	A9		
OUTPUT-5	A10	3	J80 (1) through J99 (20)
OUTPUT-6	A11		

Alarm Closure Contacts

The SSU-2000e shelf has two filtered DA15P male connectors that are electrically tied to the alarm relay contacts on the Communications module. One connector (labeled J1) is designated the local alarm connector and the second connector (labeled J2) is the remote alarm connector.

Each connector provides connections for normally open (NO), common or wiper (COM) and normally closed (NC) for each of the following alarm categories:

- **CRITICAL** – Indicates an immediate, service-affecting condition that requires immediate user intervention, such as loss of the Communications module, loss of input power to the shelf, and so forth.

When a critical alarm condition is detected, the CRITICAL ALARM relay is activated (the alarm condition) and the CRITICAL ALARM indicator (LED) on the front of the Communications module turns red unless both power inputs are interrupted. In this case the unit is not running.

- **MAJOR** – Indicates a condition that may require immediate user intervention.

When a major alarm condition is detected, the major alarm relay at the back of the SSU-2000e is activated and the MAJOR ALARM indicator (LED) on the front of the Communications module turns red.

- **MINOR** – Indicates the unit performance may be degrading.

The minor alarm relay is activated and the MINOR ALARM indicator (LED) turns on.

Table 1-4 lists the local and remote alarm connector pin assignments.

Table 1-4. Local and Remote Alarm Connector Pin Assignments

Signal	Pin
MINOR – Normally Open Contact	7
MINOR – Wiper Contact	15
MINOR – Normally Closed Contact	8
MAJOR – Normally Open Contact	4
MAJOR – Wiper Contact	12
MAJOR – Normally Closed Contact	5
CRITICAL – Normally Open Contact	1
CRITICAL – Wiper Contact	9
CRITICAL – Normally Closed Contact	2
Frame Ground	10
Frame Ground	11
Frame Ground	13
Not Used	3
Not Used	6



Note: In an alarm condition or loss of DC power, the contact between the NO and COM closes and the contact between the NC and COM opens.

Main Shelf Power Connections

The main shelf accepts redundant –48/60 VDC power inputs from external supplies and makes these inputs available to the modules through the motherboard connectors.

There is no power ON/OFF switch on the SSU-2000e because power to the shelf is controlled by external power supplies.

Main Shelf Communications Ports

The SSU-2000e main shelf contains four communication ports including:

- Two EIA-232 communication ports (Port A, J4; Port B, J5) on the upper front panel
- One shielded RJ-45 ethernet connector J3 (10baseT) on the upper front panel for network connection
- One EIA-232 port on the face of the Communications module (Local Port)

The user interface provides various levels of password-protected access for configuration and detailed performance monitoring and diagnostics. Use either the ASCII interactive command set or the TL1 user interface to configure and view detailed performance monitoring, see the *SSU-2000e Technical Reference*. The operator assigns an interface type to the remote EIA-232 ports, either interactive or TL1. When assigned, this information is retained in NVRAM. The Local port on the Communications module is always in Interactive mode when the module restarts.

Serial Port Pinouts

Figure 1-11 shows the EIA-232 connector pin assignments for the serial ports.

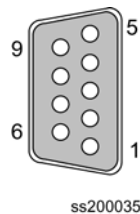

Figure 1-11. Serial Port Connector Pins

Table 1-5 describes the EIA-232 connector pin assignments for the serial ports.

Table 1-5. Serial Port Connector Pin Assignments

Signal	Pin
DCD (Data Carrier Detect) Control Line	1
RXD (Received Data)	2
TXD (Transmitted Data)	3
DTR (Data Terminal Ready Control Line)	4
Ground	5
DSR (Data Set Ready Control Line)	6
RTS (Request to Send Control Line)	7
CTS (Clear to Send Control Line)	8
RI (Ring Indicator Control Line)	9



Note: The DCE setting allows direct connection of the unit to a standard PC communications port using a 1:1 cable. The DTE setting requires a null modem cable. If connecting to a modem, use DTE.

Ethernet Connector Pinouts

The Ethernet (10baseT) pinouts are provided in [Table 1-6](#).

Table 1-6. Ethernet Connector Pinouts

Signal Name	Pin
TX+ (Positive Side of Transmitted Data)	1
TX- (Negative Side of Transmitted Data)	2
RX+ (Positive Side of Received Data)	3
RX- (Negative Side of Received Data)	6
Not Used	4, 5, 7, 8

SSU-2000e Family of Modules

The SSU-2000e family of modules includes the following:

- Stratum 2E Clock Module
- Stratum 3E Clock Module
- Type 1 Clock Module
- Communications Module
- 1-Port and 3-Port E1 Input Modules
- 1-Port and 3-Port DS1 Input Modules
- GPS Input Module
- Composite Clock Input Modules
- E1 Output Module
- DS1 Output Module
- Composite Clock Output Module
- E1/2048 kHz Output Module
- 2048 kHz Output Module
- RS-422 Output Module
- Buffer Modules

Some of the features common to each module include:

- Any module can be inserted or removed while power is applied without affecting the operation of other modules in the system.
- All modules are individually fused to protect the system in case of a short circuit on any one module.
- All modules have status LEDs on their front panel.
- All modules are equipped with ejector tabs for ease of installation and removal and secured in place with captive screws to provide module security and reduce the occurrence of unauthorized removal.
- All SSU-2000e modules have an integrated CPU with firmware and are software configurable.
- Each module slot also has three pins connected together on its assigned hybrid DIN connector which permits the system to detect when a particular module is removed. More information is available for each of these modules in [Chapter 6, Clock and Communications Module Reference Data](#), [Chapter 7, Input Module Reference Data](#), and [Chapter 8, Output Module Reference Data](#).

Clock and Communications Modules

Stratum 2E Clock Module

The Stratum 2E Clock module uses a Rubidium oscillator and meets the ITU-T and ETSI specifications for Type II Transit Node clocks. This clock also meets the requirements of ANSI and Telcordia Industries (Bellcore) for Stratum 2 clocks.

The module reads measurement data from the input modules, provide frequency control of its oscillator through DDS circuitry, and generates a reference signal used by the input and output modules. The clock module also maintains phase synchronization with the redundant clock module. For more information, see [Stratum 2E Clock Module](#), on page 144.

Stratum 3E Clock Module

The Stratum 3E Clock module meets or exceeds performance requirements for ITU and ETSI Type III Local Node clocks and ANSI and Bellcore Stratum 3E.

The Stratum 3E Clock Module reads measurement data from the Input modules, provide frequency control of the oscillators through DDS circuitry, and generates a reference signal used by the Input and Output modules. The Clock module maintains phase synchronization with the redundant Clock module. Its hardware and software also provides for temperature compensation, aging compensation for quartz oscillators, an initial offset adjustment, and frequency adjustment resolution of 1×10^{-13} or better. For more information, see [Stratum 3E Clock Module](#), on page 148.

Type I Clock Module

The Type I Clock module uses a quartz oscillator which meets or exceeds the performance requirements for ITU and ETSI Type I Slave clocks.

The Type I Clock module reads measurement data from the Input modules, provides frequency control of the oscillator through DDS circuitry, and generates reference signals used by the Input and Output modules. For more information, see [Type I Clock Module](#), on page 152.

Communications Module

The Communications module serves as the user interface to the SSU-2000e. The module command interface supports three EIA-232-C connections and one Ethernet interface for communication with the SSU-2000e system. This module also logs the unit events into non-volatile memory for inspection at a later date and reports alarms as they occur. For more information, see [Communications Module](#), on page 156.

Input Modules

1-Port and 3-Port DS1/E1 Input Modules

The DS1 and E1 Input modules are available with both 1-Port and 3-Port configurations. These modules receive signals and perform phase measurement comparisons with the Clock modules that are installed in the SSU-2000e. The Clock modules use this information to phase and frequency lock to the incoming signal. The data may also be used for monitoring the frequency of incoming signals.

The DS1 and E1 Input modules accept the following signals: sine or square wave (with frequency of 1, 1.544, 2.048, 5 or 10 MHz) or framed communications type DS1 or E1. If the input signal is a communications type, the module monitors the following errors:

- Alarm Indication Signaling (AIS)
- Bipolar Violations (BPV)
- Cyclic Redundancy Check (CRC)
- Loss of Signal (LOS)
- Out Of Frame (OOF)

The module also extracts Synchronization Status Messages (SSM) from incoming data. For more information, see [1-Port and 3-Port E1 Input Modules](#), on page 164, and [1-Port and 3-Port DS1 Input Modules](#), on page 174.

GPS Input Module

The GPS Input module is a one-port card that can only be installed in the SSU-2000e main shelf. The module is used to correct the frequency of the oscillator on the Clock module. It monitors and reports the status and performance of the module and radio signals that it receives. See [GPS Input Module](#), on page 184, for more information.

You must install this module in slot A3 or A5; the antenna connectors J6 and J7 on the rear panel are connected to these slots, respectively.

Composite Clock Input Module

The Composite Clock Input module conditions a composite clock input signal that is used to control the frequency of the Clock modules. For more information, see [Composite Clock Input Module](#), on page 188.

In Subtending mode (either ANSI or Japanese), the module also produces a 4 kHz synchronization signal that determines the phase of the composite clock signals generated by Composite Clock Output modules. This signal ensures that the phase of the composite clock output signals follows the phase of the composite clock input reference signal.

Output Modules

E1 Output Module

The E1 Output module uses one of three 4 kHz clocks from the SSU-2000e main shelf backplane to generate a phase-locked signal of 2.048 MHz. If the unit is inserted into an SDU-2000e expansion shelf, a fourth 4 kHz clock (D clock) is available. The phase-locked 2.048 MHz signal is used to generate a set of 20 output signals for distribution to large networks. See [E1 Output Module](#), on page 194, for more information.

DS1 Output Module

The DS1 Output module generates a phase-locked signal of 1.544 MHz using one of three 4 kHz clocks from the backplane of the SSU-2000e main shelf. If the module is inserted into the SDU-2000e Synchronization Distribution Unit (expansion shelf), a fourth 4 kHz clock is available. The phase-locked signal generates a set of 20 output signals for distribution to large networks. [DS1 Output Module](#), on page 198, contains detailed information on the module.

Composite Clock Output Module

The Composite Clock (CC) Output module can be installed in the SSU-2000e to generate and monitor CC signals, monitor input reference signals, accept new configuration data, and report status. This module provides 20 signal pairs (TTIP and TRING signal pairs), which are referenced to the selected clock signal. For more information, see [Composite Clock Output Module](#), on page 201.

E1/2048 kHz Output Module

The E1/2048 kHz Output module can be installed in the SSU-2000e to generate and monitor 20 independent E1/2048kHz output signals. If the module is inserted into an SDU-2000e expansion shelf, a fourth 4 kHz clock (D clock) is available. If the input signal PQL drops below a user-specified level, then the outputs can be squelched. For more information, see [E1/2048 kHz Output Module](#), on page 205.

2048 kHz Output Module

The 2048 kHz Output module plugs into selected input/output slots in the SSU-2000e main shelf or one of the output slots on the expansion shelf. The module generates and monitors 20 independent 2048 kHz signals that are referenced to a selected clock module. The 2048 kHz Output module receives a set of three (four if installed in an expansion shelf) 4 kHz clocks from the Clock modules and uses these clocks to develop an 8.192 MHz phase-locked signal. This phase-locked signal is then used to generate 20 sets of 2048 kHz clock outputs. For more information, see [2048 kHz Output Module](#), on page 213.

RS-422 Output Module

The RS-422 Output module generates 10 balanced square-wave outputs (TTIP and TRING signal pairs) and 10 single-ended (Ring) square-wave outputs. Each output can be turned off independently of other ports; relays on each output disconnect the driver output from the output pins. A squelch feature turns off selected ports when the input signal falls below predetermined quality levels. See [RS-422 Output Module](#), on page 219.

Buffer Module

The Buffer module buffers the backplane and clock signals sent from the main shelf; the modules are installed in slots 15 and 16 of the SDU-2000e. Symmetricom recommends a minimum of one Buffer module in each expansion shelf; a second Buffer module provides redundancy.

Communications Protocol

This section summarizes the methods of controlling the SSU-2000e and the available software features, depending upon the system functionality required.

Software Interface

There are four methods of controlling the SSU-2000e. The interfaces are:

TL1 – Transaction Language One

TL1 provides command sets to support all operation, administration, maintenance, and provisioning tasks required to maintain and control an SSU-2000e system. These tasks include configuring and provisioning security, monitoring system performance, configuring hardware, locating and handling faults, and performing equipment diagnosis and testing. Refer to the *SSU-2000e Technical Reference* for more information.

ICS – Interactive Command Set

ICS also provides command sets to support all operation, administration, maintenance, and provisioning tasks required to maintain and control an SSU-2000e system from a terminal connected to one of the SSU-2000e EIA-232 serial ports. ICS commands are designed in a more readable interface for users with an instructional help facility. Refer to the *SSU-2000e Technical Reference*.

NTP – Network Time Protocol

The Network Time Protocol (NTP) is used to synchronize the time of a computer client or server to another server or reference time source, such as a GPS receiver or local timing source.

The SSU-2000e implements the NTP v.3 (RFC 1305) version. It can run as a server application and a client application. In addition, a broadcast mode may be implemented as either a server or client. The NTP server always runs and the client and broadcast modes are enabled independently by assignment of addresses and setting of timers. Refer to the *SSU-2000e Technical Reference* for more information.

SNMP – Simple Network Management Protocol

The SSU-2000e offers two versions of SNMP: v2 and v3. SNMP v3 software offers additional security with authentication and privacy parameters. The security feature allows secure transactions to provide protection against modification of information, masquerade, and message stream modification.

Simple Network Management Protocol (SNMP) is based on a client-server query-response mode. A manager is the client generating the queries, while an agent is the server generating the responses.

The SSU-2000e SNMP is an SNMP agent that requires Ethernet connectivity. If SNMP is present, port 161 becomes the port of standard SNMP interactive communications, while port 162 becomes the trap port. Since the SSU-2000e SNMP supports all existing functions, full system control of the SSU-2000e is maintained through SNMP.

The SSU-2000e implements an SNMP agent. A Management Information Base (MIB) browser or the SNMP Manager is used to access, retrieve, and query information defined by the MIB.

All reports, queries, autonomous messages, control, provisioning, and administration (except for communication port parameters, Set User ID/Password, Set IP assignments, Reset connection, and SNMP community settings) are available through SNMP. Refer to the *SSU-2000e Technical Reference* for more information.

Software Versions

There are six different versions of software available for the SSU-2000e, as shown in [Table 1-7](#). The functionality and commands that are available vary from one version of software version to the next, depending on the specific features of the software package; see the *SSU-2000e Technical Reference* for more information.

Table 1-7. Communications Module Software Versions

Version	TL1	ICS	NTP	SNMP v2	SNMP v3
Basic System Load	X	X			
Basic w/NTP Support	X	X	X		
Basic w/SNMP v2 Support	X	X		X	
Basic w/SNMP v2 and NTP Support	X	X	X	X	
Basic w/SNMP v3 Support	X	X		X	X
Basic w/SNMP v3 and NTP Support	X	X	X	X	X

Basic System Load

The basic system load includes all TL1 and ICS support software. TL1 provides command sets to support all operation, administration, maintenance, and provisioning tasks required to maintain and control an SSU-2000e system. These tasks include configuring and provisioning security, monitoring system performance, configuring hardware, locating and handling faults, and performing equipment diagnosis and testing. Refer to the *SSU-2000e Technical Reference* for more information.

ICS also provides command sets to support all operation, administration, maintenance, and provisioning tasks required to maintain and control an SSU-2000e system from a terminal connected to one of the serial ports. ICS commands are designed in a more readable interface for users, and includes an instructional help facility. Refer to the *SSU-2000e Technical Reference* for more information.

Graphical User Interface

SynCraft is a software interface program that is available to provide monitoring and configuration functionality in a Microsoft Windows graphical user interface. Contact your Symmetricom Sales Representative for more information on the *SynCraft Graphical User Interface*, part number 14113245-000-0. For more information on control interfaces and the software commands available for each, see the *SSU-2000e Technical Reference*.

Overview of SSU-2000e Operation

After initial installation and configuration is completed, the SSU-2000e is capable of unattended operation. After power-up, where the external power supplies are turned on so that they supply power to the main shelf, the SSU-2000e performs a self-diagnostic test routine and properly initializes the hardware. Any active Alarms are time tagged and reported as Events. All Events are time tagged and the last 500 Events are stored in NVRAM. All Events can be cleared by the user with the appropriate access level. Several optional levels of password protection are available for system protection as described in [Chapter 2, Installing the SSU-2000e](#).

After the internal oscillators on any installed Clock modules have warmed up, the SSU-2000e enters the ACQUIRE mode to phase lock the oscillators to the external references. After the SSU-2000e reaches the LOCKED mode on at least one of the Clock modules, any change of state is reported as an Event.

Synchronization Status Messages (SSMs)

The SSU-2000e supports input and outputs SSMs. SSMs provide clock quality information to any equipment that uses synchronization inputs.

The SSU-2000e handles SSMs in accordance with T1X1.3 TR33, T1.101-1999, GR-253, 379-CORE, and ITU-T G.781.

Indicators and Controls

All modules installed in the SSU-2000e main shelf and the SDU-2000e expansion shelf contain status indicator lamps for displaying status. The LED indicators for each module are described in [Chapter 6, Clock and Communications Module Reference Data](#), [Chapter 7, Input Module Reference Data](#), and [Chapter 8, Output Module Reference Data](#). In addition, the Communications module collects status information from all installed modules, sets the alarm relays, and sends communications status alerting users of any Events that exceed alarm thresholds.

The user controls these operating limits and collects measurement data through the use of a peripheral device connected to one of three EIA-232 ports, or through the optional Ethernet connector on the front of the unit.

SDU-2000e Synchronization Distribution Unit

The SDU-2000e Synchronization Distribution Unit (Figure 1-12) is an expansion chassis that attaches to an SSU-2000e Synchronization Supply Unit and is used to generate additional output signals. The expansion chassis uses the framing and synchronization features of the SSU-2000e main chassis to drive an array of Output modules. Communication with the expansion chassis is performed through one of the three serial ports, or through the ethernet port on the main chassis front panel.

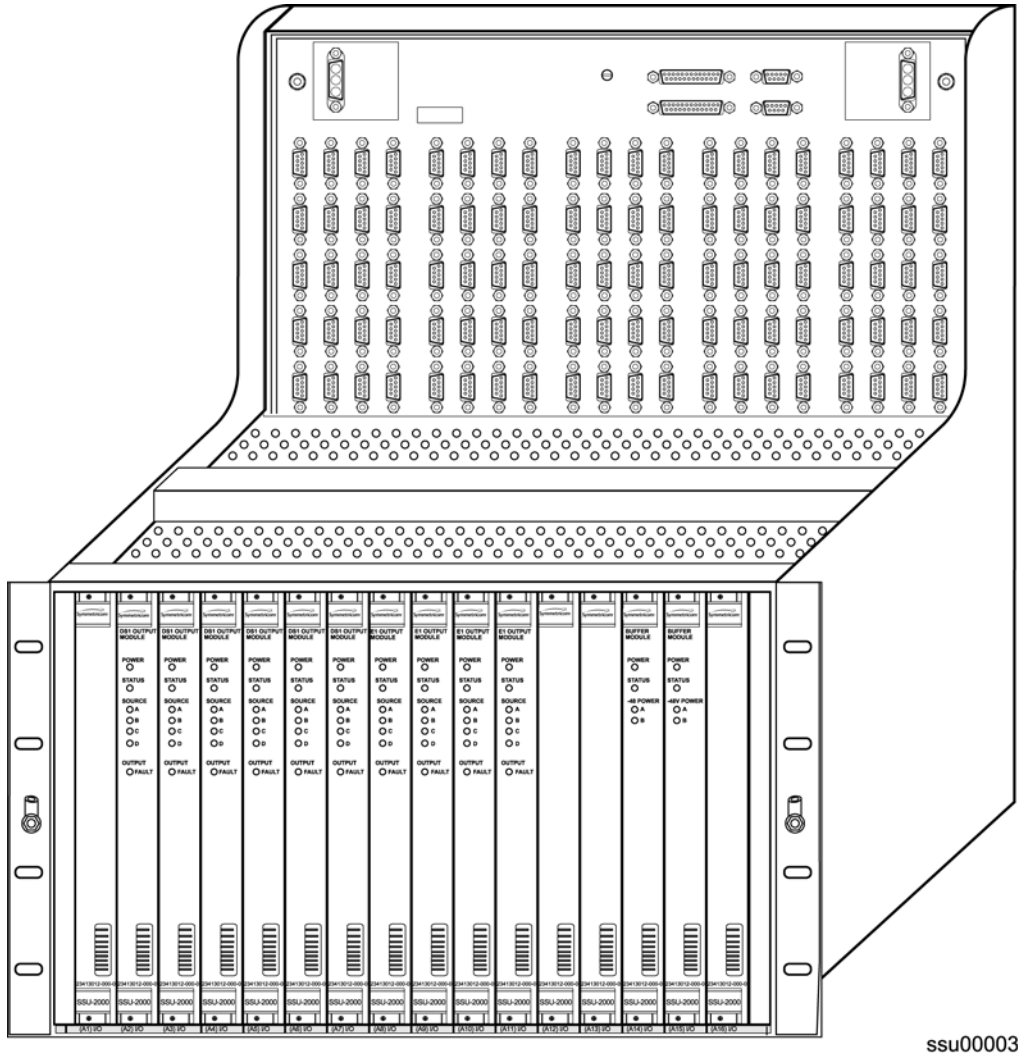

Figure 1-12. SDU-2000e Synchronization Distribution Unit

Each expansion shelf in the system can support an additional 10 summed pair Output modules, 2048 kHz, Composite Clock (CC) or framed 2048 kbit/s (E1) or DS1 Output modules in any combination and two Buffer modules. Each pair of Output modules produces 20 redundant or protected outputs. Each expansion chassis can provide 100 summed (1:1 protected) output signals. Up to four expansion chassis can be daisy chained together to produce 400 summed output signals for large scale system applications.

All output signals generated by the Output modules in each expansion shelf conform to specifications for International, European and North American applications as a primary reference source (PRS) and slave clock (SSU/TSG). The SSU-2000e, which drives the SDU-2000e expansion chassis, allows the integration of a variety of synchronization reference schemes including GPS and land line 2048 kbit/s (E1)/DS1 network sources.

The expansion chassis is designed to be compatible with international environmental, safety and electromagnetic compliant (EMC) standards for -48/60 VDC powered telecommunication transmission equipment installed in telecommunication centers with inside telecom signal connections. The farthest expansion chassis may be located up to 61 meters from the SSU-2000e main shelf.

[Figure 1-13](#) shows a simplified functional block diagram of the SDU-2000e expansion chassis.

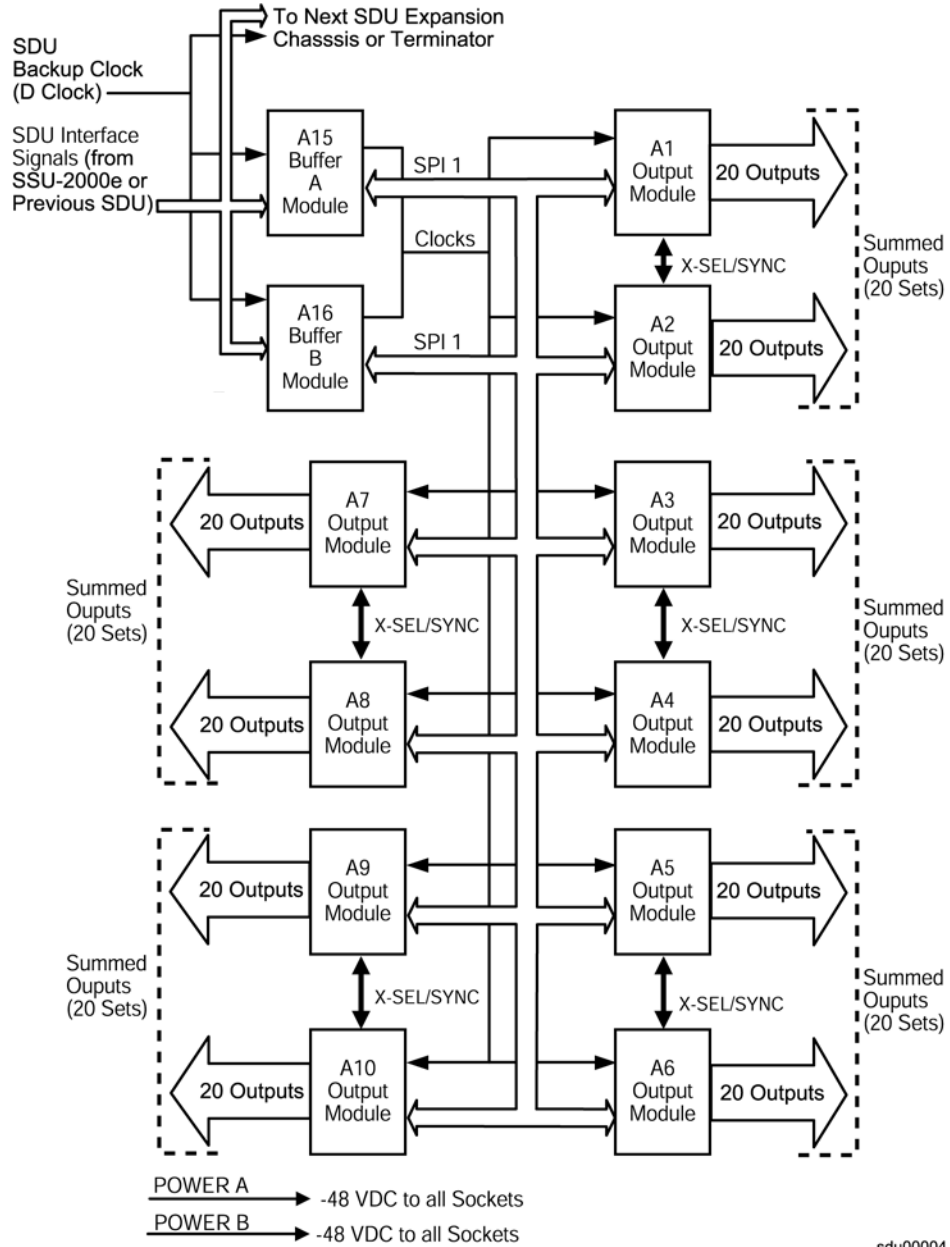

sdu00004

Figure 1-13. SDU-2000e Block Diagram

Functional Overview

The SDU-2000e interfaces with the main shelf in two-way communication through the SSSU/SDU interface cable. The SDU-2000e receives buffered synchronization clock signals that are used to produce the differential output signals at the connector panel, as shown in the functional block diagram in [Figure 1-13](#). A second interface cable supplies the SDU-2000e chassis with a backup clock (D Clock) which can sustain the expansion shelf even if the main cable is accidentally disconnected. An address switch on the connector panel of the expansion shelf identifies each additional shelf to the main shelf for status and firmware downloading purposes.

Each expansion shelf extends the expansion bus and D clock to the next chassis in the daisy chain. The last expansion shelf uses a set of termination plugs on the Expansion Bus Connector and the Backup-Clock Connector.

Each expansion shelf can support any combination of up to ten 2048 kHz, Composite Clock (CC), or framed 2048 kbit/s (E1) or DS1 modules, each capable of generating 20 output signals for distribution to large networks. Each Output module generates a phase-locked signal of 1.544 Mbps (DS1) or 2048 kbit/s (E1) using one of three 4 KHz clocks supplied by the clock oscillators in the SSU-2000e main shelf. The phase locked clock signal is buffered and summed with a companion Output module in redundant pairs to generate a set of 20 independent output clock signals for distribution to large networks.

Output modules are available to support the following formats:

- 2048 Kbit/s (E1)
- DS1, SF (D4) and ESF
- 2048 kHz
- Composite Clock (64/8 kHz)
- RS-422

Expansion Shelf Features

The SDU-2000e expansion shelf consists of the following major components and is shown in [Figure 1-14](#).

- Expansion chassis
- One or two Buffer Modules; where two provide a more robust system
- Up to 10 Output modules, which can be a combination of Output module types
- Connector panel with five groups of output connectors, SDU interface connector group, dual power connectors, dual frame ground connectors, and a shelf address switch

Clock Source

The clock inputs for the first SDU-2000e expansion chassis in an SSU-2000e system are supplied by the A and B Clock modules in the main chassis. A multi-pin connector on the front panel of the SSU-2000e (labeled J8 EXPANSION) provides the reference signals from the main shelf Clock modules for use by the SDU-2000e expansion shelves.

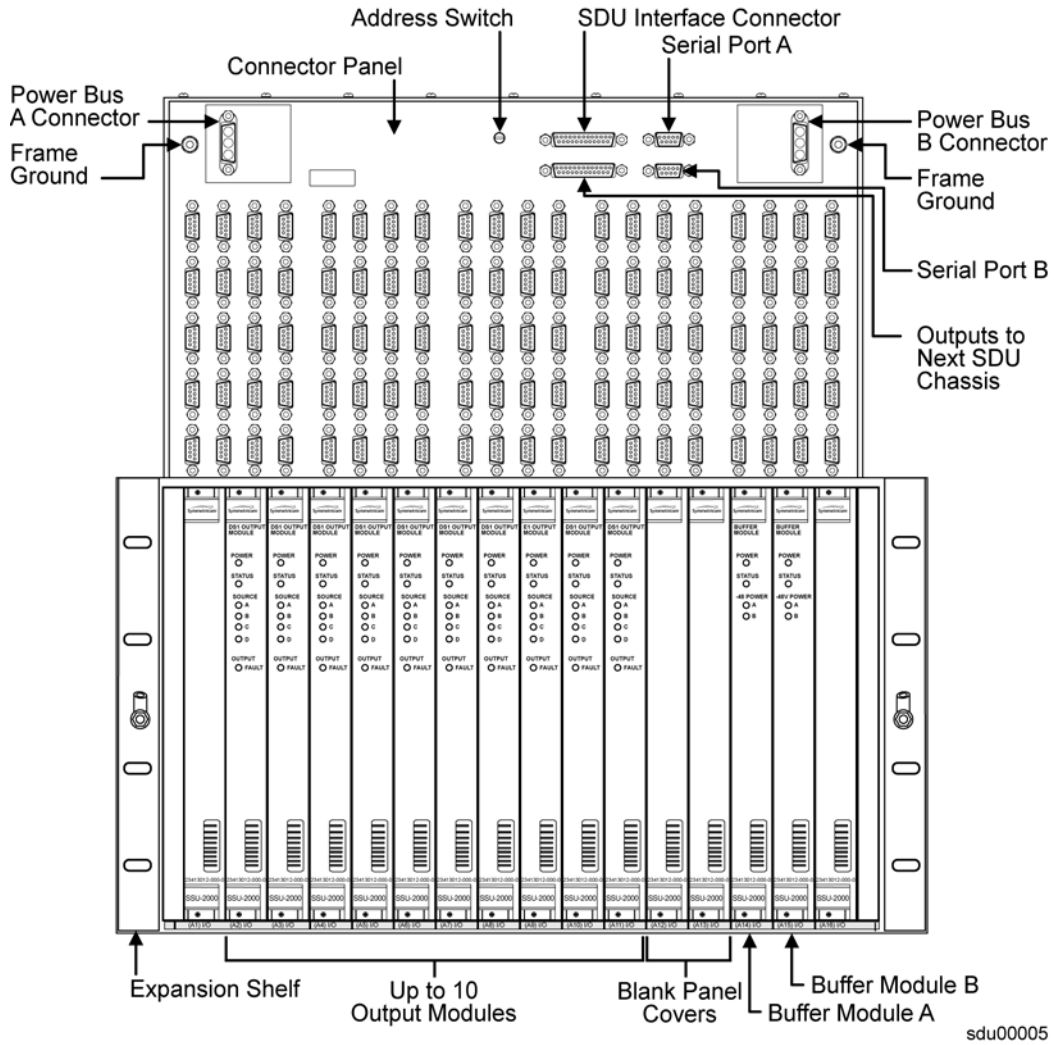

Figure 1-14. SDU-2000e Expansion Chassis Components

SDU Backup Clock

For redundancy, a backup clock, labeled SDU BACKUP CLK, is supplied to each expansion chassis to allow each expansion chassis to continue operating if the main expansion bus (cable) is accidentally disconnected or dislodged.

The SDU Backup Clock terminals, labeled J104 and J106, are 9 Pin D-type female connectors that are connected in parallel. Connector J104 is used to connect to a source unit, such as the SSU-2000e or to connector J106 on another expansion shelf. Connector J106 drives an additional SDU-2000e shelf, or it is terminated using an SDU backup clock terminator.

When installing an expansion chassis, move the clock terminator from J9 on the SSU-2000e, or connector J106 from a previous SDU-2000e expansion chassis, and install the terminator on J106 of the last expansion chassis in the daisy chain, see [Figure 1-15](#).

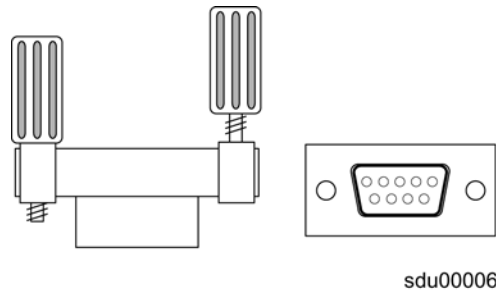

Figure 1-15. Backup Clock Terminator, Side and Front Views

Setting the Expansion Shelf Address

Each SDU-2000e expansion chassis must be correctly configured for its position in the daisy chain. The main shelf's address is 1. The SDU shelf address selector is numbered from two to five. Set the first expansion shelf address to 2. Set the address on additional shelves sequentially, as shown in [Table 1-8](#).

Table 1-8. Expansion Shelf Addressing

Shelf	Address
Main Shelf	1
Expansion Shelf 1	2
Expansion Shelf 2	3
Expansion Shelf 3	4
Expansion Shelf 4	5

Buffered Clocks

The signals that are provided by the main shelf Clock modules to the Buffer modules in the expansion shelf are isolated versions of the signals used by the Output modules in the main chassis. This prevents the expansion shelf and its cabling from affecting the outputs of the main shelf.

SDU Module Features

The SDU-2000e expansion chassis family of modules include the E1 Output module, DS1 Output module, 2048 kHz Output module, Composite Clock module, and Buffer modules. The SDU-2000e expansion chassis may have up to 12 modules installed.

- One or two Buffer modules, assigned to chassis slots A15 and A16
- One to ten Output modules; a mixture of Output module types, where each group of two modules must be identical

The last two module slots in the expansion shelf, labeled A15 and A16, contain the Buffer modules that buffer the corresponding Clock and Communications module signals from the main shelf. The buffered signals from these modules are distributed through the motherboard to 10 Output modules.

Other common module features include:

- Any module can be inserted or removed while power is applied without affecting the operation of other modules in the system
- All modules are individually fused to protect the system in case of a short circuit on any one module
- The SSU-2000e and the SDU-2000e share common Output modules
- All modules have front panel LED status indicators
- All modules are equipped with ejector tabs for ease of installation and removal
- All modules are secured in place with captive screws to provide module security and reduce the occurrence of unauthorized removal
- All modules, except the Buffer module, have an integrated CPU with firmware and are software configured through the SSU-2000e, see [Configuring a Conventional SSU/TSG System](#), on page 228, for additional information
- Each module slot has two associated hybrid DIN connectors on the chassis backplane. The hybrid contacts of these connectors are used for Power, Logic Ground, and Frame Ground connections
- Each module slot has three pins on each Hybrid DIN connector that allow the system firmware to detect module removal and insertion. This provides plug-and-play capability.

Connector Panel Features

The expansion chassis provides front-accessible connections for external power, grounding, clock inputs, and output connections. All modules plug in from the front of the chassis.

Power Input and Grounding

The SDU-2000e expansion chassis has redundant –48/60 VDC power input connections, labeled A-BUS and B-BUS (J101 and J102). Both the A-BUS and B-BUS are fed to the individual module slots through the chassis backplane.

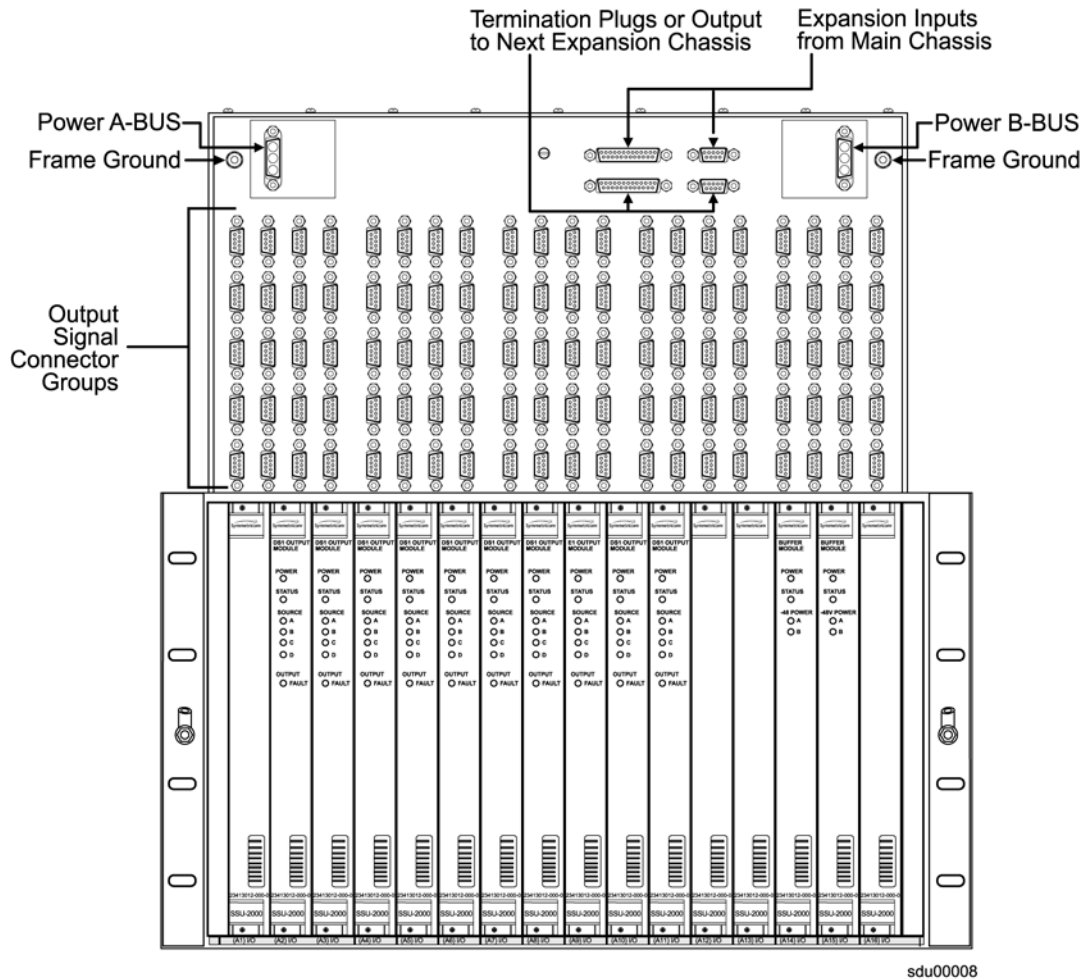

Figure 1-16. SDU-2000e Connection Features

Expansion Connectors

Up to four SDU-2000e expansion shelves can be attached to the SSU-2000e main shelf. The two terminators (SSU Expansion Terminator and SDU Backup Clock Terminator) must be moved from the SSU-2000e chassis (connectors J8 and J9) to connectors J105 and J106, respectively, on the last expansion chassis in the daisy chain. A simplified expansion cabling diagram is shown in [Figure 1-17](#).

Output Module Redundancy Configurations

For each A/B pair of Output modules, the outputs of module B are connected to the corresponding outputs of module A. This provides for 1:1 output protection (1:1 redundancy).

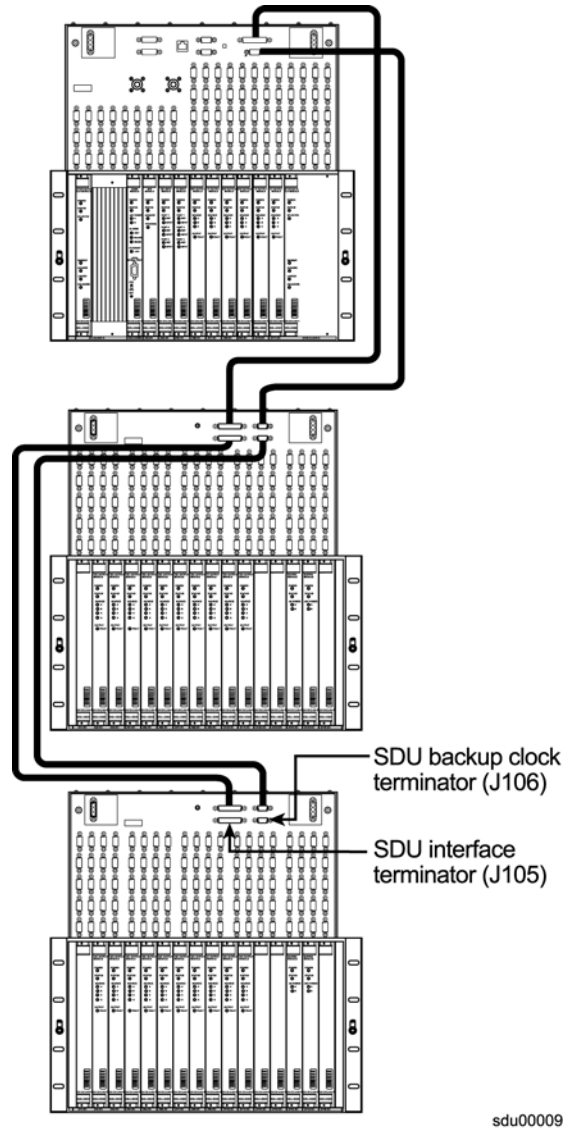

Figure 1-17. Expansion Chassis Cabling

Controls and Indicators

All modules installed in the SDU-2000e expansion shelf contain LED status indicators for displaying status. Any faults from the installed modules are sent to the SSU-2000e Communications module through the buffer modules; the appropriate alarm relays are set and communication status is sent to alert users of any events that exceed specified alarm thresholds.

Chapter 2 Installing the SSU-2000e

This chapter provides guidelines and procedures for installing the SSU-2000e Synchronization Supply Unit and the SDU-2000e Expansion shelf, and for bringing the unit on-line after installing it.

In This Chapter

- [Unpacking and Inspecting the Shelf](#)
- [Preliminary Procedures](#)
- [Rack Mounting the SSU-2000e](#)
- [Making Ground and Power Connections](#)
- [Making Communications Connections](#)
- [Making Signal Connections](#)
- [Making Alarm Connections](#)
- [Connecting Antennas](#)
- [Handling Modules](#)
- [Installing the SDU-2000e](#)
- [Installation Checklist](#)
- [SSU-2000e Turn-Up Procedures](#)
- [SDU-2000e Turn-Up Procedures](#)
- [After Turn-Up](#)

Unpacking and Inspecting the Shelf

The SSU-2000e is packaged to protect it from normal shock, vibration, and handling damage. To avoid damaging the unprotected unit, caution is advised during unpacking and installation.



Caution: To avoid damage, use proper static control precautionary measures when handling the modules. Protect the equipment against electrostatic discharge (ESD) by using a protective wrist-strap attached to ground and normal equipment grounding.

1. Unpack all equipment carefully and check it against the purchase order.
2. Inspect the equipment for shipping damage, including bent or loose hardware, broken connectors, or other visible defects. Notify Symmetricom and the carrier who delivered the equipment if you suspect damage occurred during transit.

If any items are missing, contact Symmetricom Global Services.



Recommendation: Keep all packaging materials in the event the system or components must be returned or shipped to another location.

Preliminary Procedures

Make sure that the following preparations are in place before installation.

- Ensure that standard installation tools and materials are available, see [Installation Tools and Materials](#), on page 59.
- The installation site is secured:
 - Access to the location can only be gained by service personnel or users who have been instructed about the reasons for the restrictions applied to the location and about any precautions that shall be taken; and
 - Access is through use of a tool or lock and key, or other means of security, and is controlled by the authority responsible for the location
- Ensure that the system location does not cause electromagnetic interference with other equipment in the area, see [Electromagnetic Interference \(EMI\) Considerations](#), on page 59.
- Ensure that adequate ventilation space is available in rack or equipment cabinet to safely operate the system, see [Ventilation Considerations](#), on page 60.
- The SSU-2000e is suitable for installation over concrete or other non-combustible surfaces only.

- Ensure that the mounting rack or equipment cabinet is properly grounded and has power available, see [Making Ground Connections](#), on page 62.



Caution: To avoid electrostatic discharge (ESD) damage to equipment, follow the ESD precautions as listed in this guide.



Recommendation: Symmetricom recommends that you follow all applicable local building electrical codes when installing the SSU-2000e.

Installation Tools and Materials

The following required standard tools and materials are required, but not supplied for installing the SSU-2000e system.

- Standard tool kit
- Cable ties or acceptable cable clamps
- 1.31 mm² (minimum) wire for –48V, RTN, and frame ground
- 0.326 mm² shielded twisted pair wire-wrap cable (Amp #640433-7 or equivalent)
- Screws, flat washers, and locking washers for mounting the equipment rack
- DA3W3P mating connectors for mounting the power input
- Digital Voltmeter (DVM)
- Straight-through RS-232 cable
- Laptop computer or PC with a terminal emulation program such as HyperTerminal or ProComm Plus

Electromagnetic Interference (EMI) Considerations

Electromagnetic interference (EMI) from one instrument can adversely affect the operation of nearby equipment. To prevent the SSU-2000e from interfering with other equipment, it must be installed and operated as described in the following paragraphs.

All cables connected to the SSU-2000e should be shielded with metal connector shells. The connectors on the front of the chassis are shielded, with the shields connected to frame ground. Follow local procedures for shield grounding. The screws on all cables must be securely fastened to their corresponding connectors on the unit. While the unit is in operation, there must be a module or blank filler panel installed in every slot. Ensure that the captive screws located at the top and bottom of the module panel are properly secured.



Caution: To maintain EMC compliance, use only properly shielded cabling on all telecom signal wiring, including I/O, clocks, and Ethernet connections. Ensure that connections are properly grounded.

Ventilation Considerations

For proper ventilation, there should be at least 76 mm (2 RU) of free space below the shelf.



Caution: To avoid excessive heat build-up resulting in equipment damage, provide proper ventilation and cooling of the equipment.

Rack Mounting the SSU-2000e

The SSU-2000e shelf is passive and contains all the necessary interconnecting signals to support a combination of plug-in modules. For example, the SSU-2000e may be configured to contain two Clock modules, a Communications module, three Input modules, and six Output modules configured with three pairs of summed outputs.



Warning: To avoid serious personal injury or death, exercise caution when working near high voltage lines. In particular:

- Use extreme caution when installing the GPS antenna near, under or around high voltage lines.
 - Follow local building electrical codes for grounding the antenna system that is used with the SSU-2000e unit.
-



Caution: For continued fire protection, fuse the interface “A” power feeds at the power distribution source for (5A @ 60 VDC).

This unit must be grounded. Refer all servicing to qualified personnel.

The SSU-2000e shelf also provides specific connections for the following:

- Grounding, see [Making Ground Connections](#), on page 62
- External Power Inputs, see [Making Power Connections](#), on page 62
- Communications Interfaces, see [Making Communications Connections](#), on page 63
- Alarm Contact Closures, see [Making Alarm Connections](#), on page 71
- Clock Inputs, see [Making Input Connections](#), on page 67

- Clock Outputs, see [Making Output Connections](#), on page 70

All SSU-2000e modules are equipped with card ejectors and plug in from the front of the chassis. Each module is secured in the chassis with captive screws.

The SSU-2000e may be mounted in either a 300 mm or 600 mm deep equipment cabinet. The SSU-2000e chassis occupies 500 mm vertically, 229 mm depth, and a width of 431.8 mm. Included are 530 mm ETSI compatible rack mounting ears. Optional 480 mm rack mounting ears are available for 480 mm EIA racks and cabinets.

The front panel of the chassis mounts flush to the rack or at a distance of 25 mm from the front of the rack. An SSU-2000e equipment cabinet mounting diagram is shown in [Figure 2-1](#).

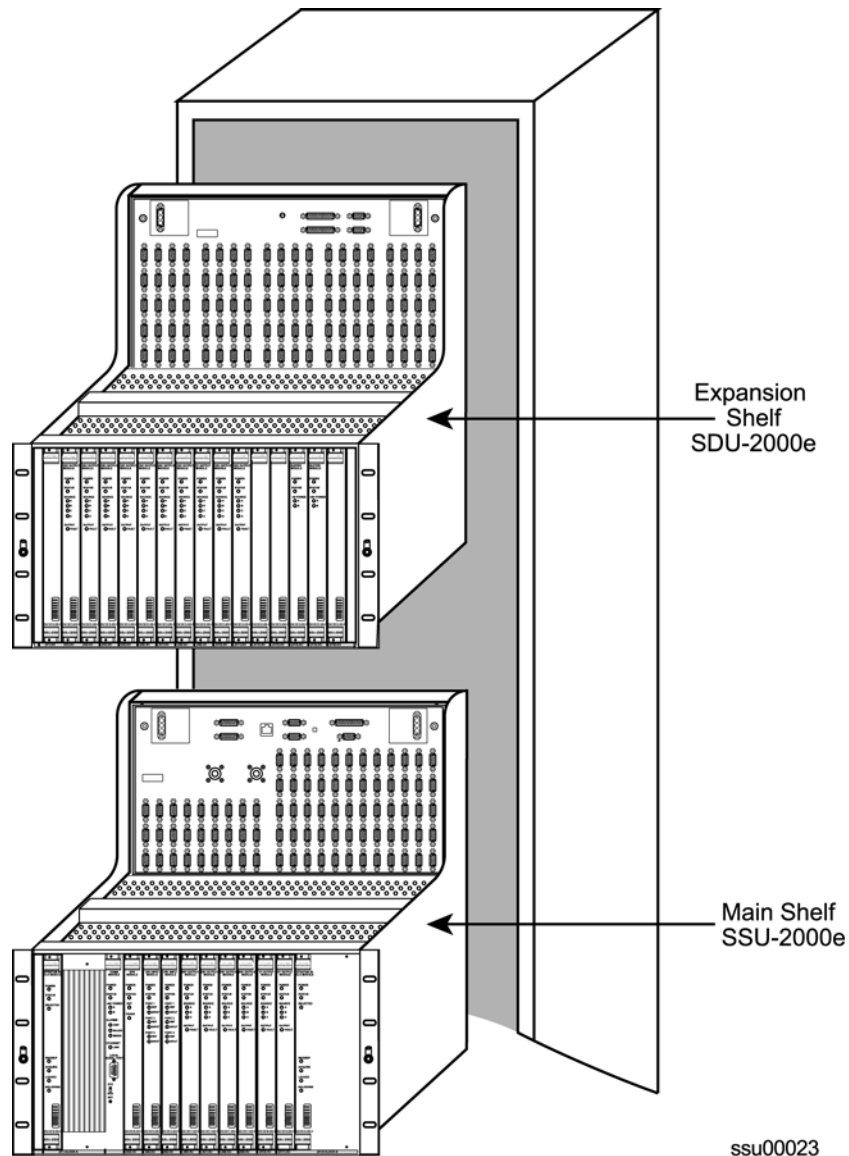

Figure 2-1. Equipment Mounting Cabinet

To install the SSU-2000e in the mounting rack:

1. Attach a mounting bracket to each side of the chassis by aligning two columns (three holes per column) of the bracket with the holes on the side of the chassis. Use appropriate screws for attaching the mounting bracket. Ensure that both brackets are attached at equal distances from the front of the unit.
2. Mount the SSU-2000e to the front of the rack rails with the appropriate number of screws and washers for the rack.



Recommendation: To aid in viewing and when connecting cables, install the SSU-2000e chassis at eye level whenever possible.

Making Ground and Power Connections

Making Ground Connections

After installing the SSU-2000e in a suitable equipment cabinet, connect the chassis to a proper earth ground. This can best be accomplished by running a cable from the frame ground lug and connecting it to the equipment cabinet. Keep this cable as short as possible. Frame ground connections are made through two M5 studs labeled *FG* located next to the power connectors in the upper right and left corners of the shelf. Frame and logic ground are connected together on the backplane to form a multi-point ground system.

Using a digital voltmeter, measure between the ground and chassis and verify that no voltage potential exists between them.

Making Power Connections

The SDU-2000e Main shelf has redundant $-48/60$ VDC power input connections, labeled J101 A-BUS and J102 B-BUS. The A-BUS connection is a DA3W3P connector located in the upper left corner and the B-BUS connection is another DA3W3P connector located in the upper right corner.

Refer to [Figure 2-2](#) for power connections. Pin 1 of each connector is not used. Pin 2 of each connector is $-48/60$ VDC and pin 3 is the Return. The $-48/60$ VDC power inputs have feed-through Pi-filters on each line through the front panel and DC Isolated from Frame and Logic ground. The power return connections are connected to Frame and Logic ground. Both the A-BUS and B-BUS power are fed to the individual module slots through the backplane.



Caution: To damage to the shelf requiring return of the shelf to the factory, **do not** reverse the polarity on the power connectors. The SSU-2000e chassis is not protected from reverse polarity.

To connect the power input, perform the following steps:

1. Remove the power supply fuse(s) that feed the SSU-2000e. You install the fuses after you make all power, signal, and alarm connections.
2. Attach 1.29 mm² (minimum) stranded wire to two DA3W3P connectors (supplied) as shown in [Figure 2-2](#).
3. Attach the connectors to the A-bus and B-bus power terminal blocks on the upper corners of the front panel.

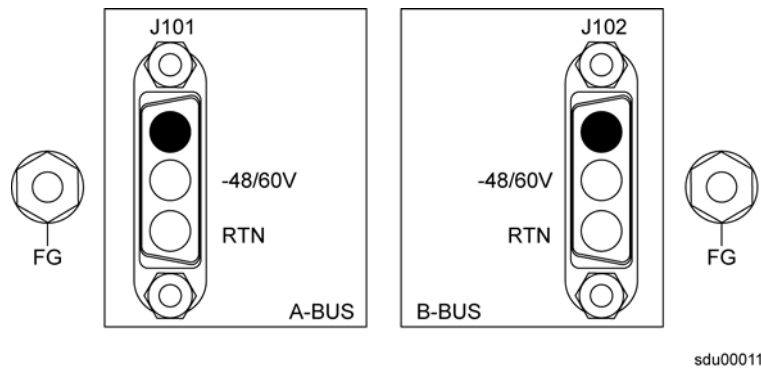

Figure 2-2. SSU-2000e Power Input Connector

Making Communications Connections

The SSU-2000e shelf has connections for three communication interfaces: two EIA-232 serial ports and one Ethernet port. There is also a 2PDT slide switch, labeled S1, associated with the serial ports. Refer to [Table 2-1](#) for the serial and Ethernet communications port assignments.



Note: A third EIA-232 serial port may be connected via the Communications module. Refer to [Chapter 6, Clock and Communications Module Reference Data](#), for more information on the Communications Module.

Table 2-1. Communications Port Assignments

Port #	Function	Protocol
Serial Ports (EIA-232)		
A (J4)	This port is user selectable as either an ICS or a TL1 interface. The port defaults to ICS upon initialization	ICS (Default), TL1
B (J5)	This port is user selectable as either an ICS or a TL1 interface. The port defaults to ICS upon initialization	ICS (Default), TL1
Local (Comms Module)	This port is user selectable as either an ICS or a TL1 interface. The port defaults to ICS upon initialization	ICS (Default), TL1
Ethernet Ports (Telnet)		
23	This port is user selectable as either an ICS or a TL1 interface. The port defaults to ICS upon initialization	ICS (Default), TL1
123	This port is designated for NTP only	NTP
161	This port is designated for SNMP Interactive	SNMP Interactive
162	This port is designated for SNMP Trap transmission	SNMP Trap
2000	This port is designated for TL1 only	TL1

Making EIA-232 Serial Port Connections

Both EIA-232 serial port connections are made through filtered DE9S female connectors on the front panel. These ports allow connection to a dumb terminal or PC using a terminal emulation software package for remote monitoring and control. One port is in connector J4 and is labeled SERIAL PORT-A, the other port is in connector J5 and is labeled SERIAL PORT-B. When connecting to these ports, use a shielded cable EIA-232 direct connect cable with the cable shield connected to pin 1, see [Figure 2-3](#).

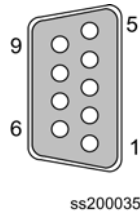

Figure 2-3. DE9 Connector Detail

The default EIA-232 settings for both serial ports are 9600 baud, no parity, 8 data bits, 1 stop bit, echo on, ASCII mode, and handshaking disabled.

Using the EIA-232 Serial Port DTE and DCE Switch

The serial port DTE and DCE switch is located on the right side of the serial ports A and B on the front panel. Each port may be configured as either DCE (default, connection to PC) or DTE (connection to modem). The upper position is labeled A and the lower position is labeled B as shown in [Figure 2-4](#).



Note: The DCE setting allows direct connection of the unit to a standard PC communication port using a 1:1 cable. The DTE setting requires a null modem cable. If connecting to a modem, use DTE.

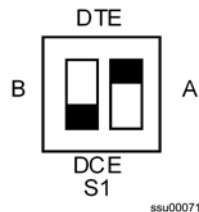

Figure 2-4. Serial Port DTE/DCE Switch

Changing Communications Settings

The default EIA-232 settings for both serial ports (Port A, J4 and Port B, J5) are 9600 baud, no parity, 8 data bits, 1 stop bit, echo on, ASCII mode, and handshaking disabled. To change these settings, perform the following steps.

1. Connect the serial communication cable from the DE-9 female connector on the PC or laptop to the interface remote terminal PORT-A (J5).
2. Verify that the slide switch is set to the appropriate equipment type, either data terminal equipment (DTE) or data communications equipment (DCE).
3. Connect a PC or laptop with terminal emulation software (such as Microsoft HyperTerminal) or ASCII terminal to the port.
4. Log in to the SSU-2000e at user level 2 or higher.
5. Use the COMM command to change the communications settings for the port. Refer to the *SSU-2000e Technical Reference* for a complete description of the Transition Language One (TL1) command interface mode and the Interactive Command Set (ICS) ASCII mode.

Making Ethernet Connections

The Ethernet 10-Base-T connection is a shielded RJ-45 receptacle, labeled Ethernet 10baseT (J3) on the front panel. The RJ-45 is the standard 10-Base-T connector. To attach the SSU-2000e to an Ethernet network, connect a standard unshielded twisted pair (UTP) Ethernet RJ-45 cable to J3 on the front panel.

Table 2-2 lists the Ethernet communications port signal connections.

Table 2-2. Ethernet Connector (J3) Pinouts

Name	Pin
TX+ (Positive Side of Transmitted Data)	1
TX- (Negative Side of Transmitted Data)	2
RX+ (Positive Side of Received Data)	3
RX- (Negative Side of Received Data)	6
Not Used	4, 5, 7, 8

Making Communications Module Connections

The Communications module serves as the user interface to the SSU-2000e. This module's command interface supports three EIA-232-C serial connections and one Ethernet interface for communication with the SSU-2000e. Figure 2-5 shows an example of connecting to the local port on the front of the communication module. The PC or terminal must be configured for 8 data bits, no parity, 1 stop bit, and 9600 baud rate.

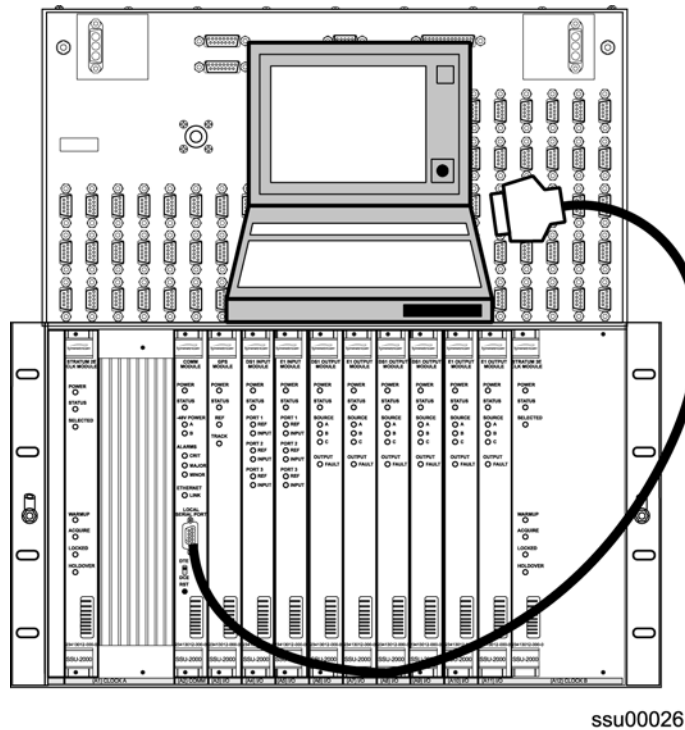

Figure 2-5. Communications Module Serial Connection

Communication control input and output requirements are listed in [Table 2-3](#).

Table 2-3. Communication Requirements for Control Input and Output

Parameter	Requirements
EIA-232	
EIA-232, 2 each	1 (PORT-A J15) designated as remote 1 (COMMS J1) designated as local
Type	Remote PORT-A is DTE or DCE, switch selectable. Local COMMS (J1) is fixed DCE.
Connector	9 pin D-Type female connector
Ethernet	
Ethernet (10baseT)	TCP/IP Telnet connections for communication and control Telnet session ICS Port Network Time Protocol (NTP) for Time of Day
Connector	RJ-45

Making Signal Connections

Making Input Connections

The SSU-2000e Main shelf has nine sets of reference clock input connections on DE9P male connectors for connecting input telecom signals. There are three connectors in each set; each set is arranged vertically and labeled top to bottom Monitor, Load, and Input, as shown in [Figure 2-6](#). There are three sets associated with each input module, creating three groups for a total of 27 connectors.

Connections for group one are made in connectors J10 through J18, group two in connectors J19 through J27, and group three in connectors J28 through J36. The Load and Input connectors are cross-wired as four-wire east-west connections. The Input connector is used for the reference input to the unit. The Load connector is used for termination of the input in a two-wire input connection and is used as a bridge or bypass connector in a four-wire or bridging connection. The Monitor connector is connected as a 20 dB monitor to the reference input signal.

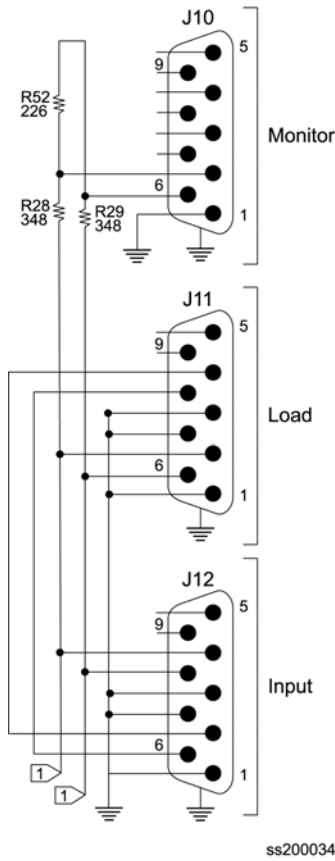

Figure 2-6. Clock Input Connector Pinout

Figure 2-7 shows the non-payload E1 (2048 kbit/s) and DS1 (1544 kbit/s) input termination.

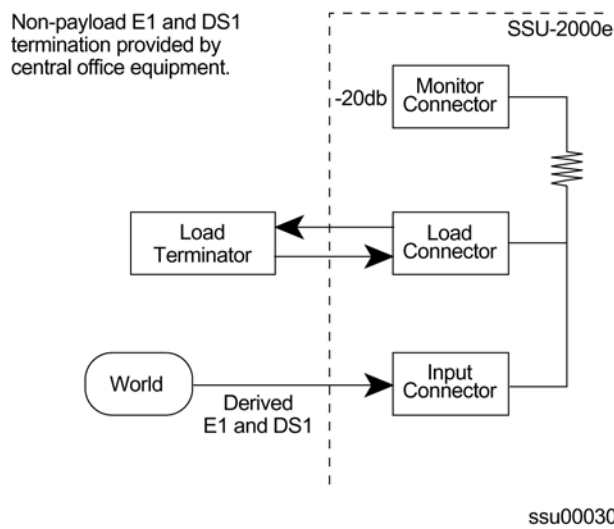

Figure 2-7. Non-Payload E1 and DS1 Input Termination

Figure 2-8 shows the *through payload* E1 and DS1 input termination.

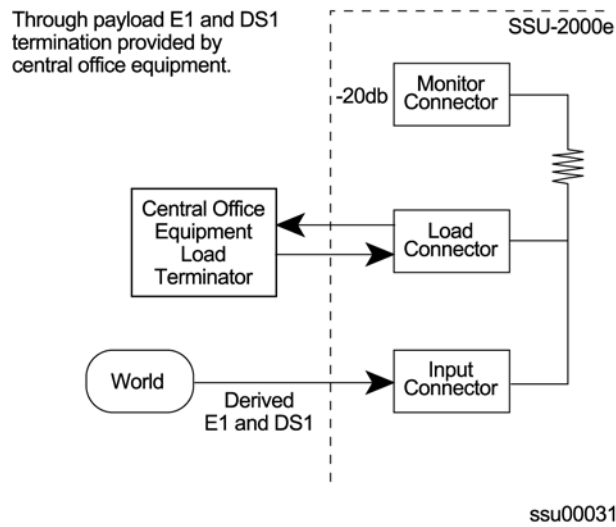

Figure 2-8. Through Payload E1 and DS1 Input Termination

Each connector is associated with a specific input plug-in module slot. Table 2-4 describes the relationship between the connectors and the Input module slot connectors. The signal connections on these connectors are set up in differential pairs as Tip and Ring connections. Plugs are available for termination of input reference.

Table 2-4. Input Module Slot to Connector Relationship

Slot Label (Name)	Plug-in Module Slot	Module Input Port	Connector Reference Description		
			Monitor	Load	Input
INPUT-1	A3	1	J10	J11	J12
		2	J13	J14	J15
		3	J16	J17	J16
INPUT-2	A4	1	J19	J20	J21
		2	J22	J23	J24
		3	J25	J26	J27
INPUT-3	A5	1	J28	J29	J30
		2	J31	J32	J33
		3	J34	J35	J36

Making Output Connections

The SSU-2000e main shelf has three groups of summed clock output connections on DE9P male connectors for connecting output telecom signals, see [Figure 2-9](#). There are twenty connectors in each group for a total of sixty output connections. The connectors in each group are arranged vertically in a five by four matrix and labeled from top to bottom, and from left to right. Connections for group one are made in connectors J40 through J59, connections for group two are made in connectors J60 through J79, and connections for group three are made in connectors J80 through J99.

Each connector is associated with a specific pair of output plug-in module slots. [Table 2-5](#) describes the relationship between the connectors and the Output module slot connectors. The signal connections on these connectors are set up in differential pairs as Tip (pin 6) and Ring (pin 2) connections, with pin 1 as ground.

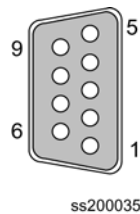

Figure 2-9. Clock Output Connector Pinout

Table 2-5. Output Module Slot to Connector Relationship

Slot Label (Name)	Plug-in Module Slot	Group	Output Connector (Module Port) Reference Description
OUTPUT-1	A6	1	J40 (1) through J59 (20)
OUTPUT-2	A7		
OUTPUT-3	A8	2	J60 (1) through J79 (20)
OUTPUT-4	A9		
OUTPUT-5	A10	3	J80 (1) through J99 (20)
OUTPUT-6	A11		

Terminating SDU-2000e Interface Connections

If you are installing an SDU-2000e expansion shelf, follow the procedures in [Installing the SDU-2000e](#), on page 78. If you are not installing an expansion shelf:

1. Install the BUS Termination Assembly (12013049-000-0-1, shown in [Figure 2-10](#)) on connector J8 of the main shelf.
2. Install an SDU Backup Clock terminator (551021-0040, shown in [Figure 2-11](#)) on connector J9.



Notes:

If you are not installing expansion shelves, you *must* install the Expansion and Backup Clock Terminators on connectors J8 and J9 on the SSU-2000e.

The signals on connectors J8 and J9 are in differential pairs. Each pair is terminated with a series 1000 pf capacitor (J8) and a 120 Ω resistor (J9) on external plug-on terminators with locking slide latch.

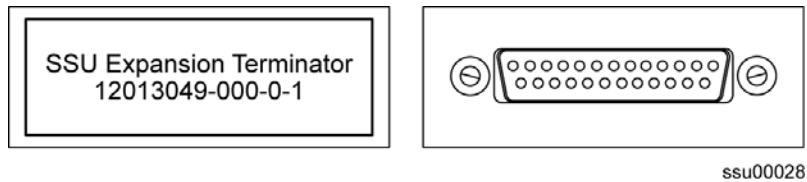

Figure 2-10. SSU Expansion Terminator (J8)

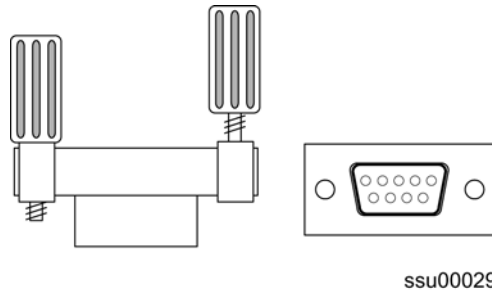

Figure 2-11. SSU Backup Clock Terminator (J9) Side and Front View

Making Alarm Connections

The SSU-2000e Shelf has two filtered DA15P male connectors for local and remote alarm contact closure connections, as shown in [Figure 2-12](#). The local connections are made on J1 and the remote connections are made on J2. The connectors are labeled ALARM CLOSURES, LOCAL (J1) and REMOTE (J2). They each have connections for normally open (NO), common or wiper (COM), and normally closed (NC) for each of these alarm categories: CRITICAL, MAJOR and MINOR.

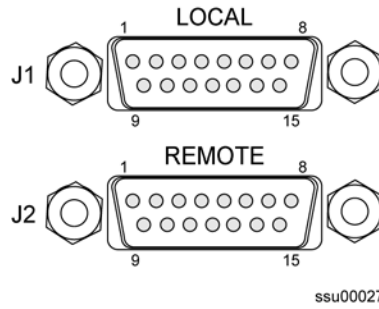

Figure 2-12. Alarm Contact Closures and Pin Assignments

Alarm contact pin assignments are listed in [Table 2-8](#).

Table 2-6. Alarm Contact Pin Assignments

Signal	Pin
MINOR – Normally Open Contact	7
MINOR – Wiper Contact	15
MINOR – Normally Closed Contact	8
MAJOR – Normally Open Contact	4
MAJOR – Wiper Contact	12
MAJOR – Normally Closed Contact	5
CRITICAL – Normally Open Contact	1
CRITICAL – Wiper Contact	9
CRITICAL – Normally Closed Contact	2
Frame Ground	10
Frame Ground	11
Frame Ground	13
Not Used	3
Not Used	6



Note: In an alarm condition or with the loss of DC power, the contact closes between NO and COM, and the contact opens between NC and COM.

Connecting Antennas

The SSU-2000e chassis has two antenna connections located on the front panel. The antenna connections are made via a Type-N connector J6 labeled ANTENNA-A and isolated TNC connector J7 labeled ANTENNA-B. These connections are used for radio receiver antenna connections only. Refer to the *SSU-2000e Technical Reference* for installation procedures and additional instructions.



Warning: To avoid serious injury to personnel or damage to equipment, exercise caution when working near high voltage lines. In particular:

- Use extreme caution when installing the GPS antenna near, under, or around high voltage lines.
- Follow local building electrical codes for grounding using the frame ground lugs integrated with the SSU-2000e chassis.
- The in-line amplifier receives 5 VDC power from the GPS radio receiver, and is supplied on the center conductor of the LMR-400 or equivalent coaxial cable. If the application requires an in-line amplifier, mount the amplifier/plate assembly where the transient eliminator would normally be mounted.
- Symmetricom does not recommend cutting the antenna cables provided in the GPS Antenna Kit.

Handling Modules

The SSU-2000e main shelf has twelve plug-in module slots. The module slots are numbered from left to right looking at the front of the shelf, A1 through A12. Each module slot has a specific address as listed in [Table 2-7](#). Each module slot has two hybrid DIN connectors associated with it on the backplane. The hybrid contacts of these connectors are used for power, logic ground, frame ground, and radio frequency (RF) connections. Each module slot has three pins connected together on each Hybrid DIN connector which are used for module removal detection. Signals on the back panel are configured as differential pairs unless they are considered static, or because of the signal type, they are required to be single ended.

Table 2-7. Module Slot Addresses in the Main Shelf

Module Type	Slot	Address
Clock Module A	A1	1A01
Communications Module	A2	1A02
I/O Module	A3	1A03

Table 2-7. Module Slot Addresses in the Main Shelf (Continued)

Module Type	Slot	Address
I/O Module	A4	1A04
I/O Module	A5	1A05
I/O Module	A6	1A06
I/O Module	A7	1A07
I/O Module	A8	1A08
I/O Module	A9	1A09
I/O Module	A10	1A10
I/O Module	A11	1A11
Clock Module B	A12	1A12



Caution: To avoid equipment damage due to poor ventilation and EMI considerations, each slot in the SSU-2000e must be filled. Filler panels are available from Symmetricom for unpopulated slots.

When handling the modules, observe the following precautions:

- Use proper static control precautions when handling modules. Protect the equipment against electrostatic discharge (ESD) by using a grounded protective wrist strap and normal equipment grounding.



Note: Two frame ground connectors, one on each mounting bracket on the sides of the unit, provides a ground connection for the protective wrist straps.

- Avoid touching component leads and the module's edge connectors.
- Avoid placing the module on any ungrounded surface.
- Avoid allowing the module to come in contact with insulated surfaces.



Caution: To avoid the possibility of the lithium battery exploding if replaced incorrectly in the Communications or Clock modules, **do not** replace the battery. Return the entire module to Symmetricom Global Services for battery replacement and disposal.

Installing a Module

The following procedure is common for all modules in the SSU-2000e and SDU-2000e.



Note: Modules can be removed and installed while system power is applied without damage to the modules and without affecting system operation, unless otherwise indicated.

Install the modules by performing the following steps.

1. Align the module card edges with the plastic card guides of the selected slot.
2. Slide the module into the chassis until it seats fully into its rear panel edge connector.
3. Tighten the captive screws located at the top and bottom of the module front panel.



Caution: Ensure that you have completely inserted the module into the system and that you have securely tightened the captive screws. A partially inserted module can become easily damaged and cause intermittent failures.

4. Enable the module using either ICS or TL1 commands. The following example commands enable the module in slot 3 in the main shelf.

ICS command:

Type `CONFIG 1A3 ENABLE`, then press **Enter**.

TL1 command:

`ACT-MODULE::S1A3:123;`

Exchanging a Module

Use this procedure to exchange one type of module with the same type or a different type of module in the same slot. The example commands are for slot 3 in the main shelf.

1. Connect to the SSU-2000e using one of the methods described in [Establishing a Connection With the SSU-2000e](#), on page 90. The system prompts for a user name.
2. Log in to the system using your user name and password.
3. Disable the module using either ICS or TL1 commands. The example commands are for slot 3 in the main shelf.

ICS command:

Type `CONFIG 1A3 DISABLE`, then press **Enter**.

TL1 command:

`DISC-MODULE::S1A3:123;`

4. Loosen the captive screws located at the top and bottom of the module front panel.
5. Pull up on the top extractor and down on the bottom extractor to unseat the module from the connector on the backplane.
6. Slide the module out of the shelf.
7. Insert the new module into slot 3 of the main shelf. Tighten the captive screws on the front panel of the module. Wait for the “module installed” message to appear.



Note: Be sure that the I/O Adapter port is of the proper type and impedance for the new module.



Caution: To avoid possible damage and intermittent failures, ensure that you have completely inserted the module into the system and that you have securely tightened the captive screws.

8. Enable the module using either TL1 or ICS commands:

ICS command:

Type `CONFIG 1A3 ENABLE`, then press **Enter**.

TL1 command:

`ACT-MODULE::S1A3:123;`

9. Verify that the module is entered in the registry:

ICS command:

Type `CONFIG`, then press **Enter**.

TL1 command:

`RTRV-INV:::123;`

Disabling a Module

Use this command to temporarily disable a module without removing it from the SSU-2000 registry. All outputs from the disabled module will turn off, unless a summer adapter is installed on the I/O connector on the rear panel of the shelf. The example commands are for slot 3 in the main shelf.

1. Connect to the SSU-2000e using one of the methods described in [Establishing a Connection With the SSU-2000e](#), on page 90. The system prompts for a user name.
2. Log in to the system using your user name and password.
3. Disable the module using either ICS or TL1 commands:

ICS command:

Type `CONFIG 1A3 DISABLE`, then press **Enter**.

TL1 command:

`DISC-MODULE::S1A3:123;`

Removing Modules

This procedure describes how to permanently remove a module from the shelf.



Note: Modules can be removed and inserted while system power is supplied without damaging modules or affecting system operation.

1. Connect to the SSU-2000e using one of the methods described in [Establishing a Connection With the SSU-2000e](#), on page 90. The system prompts for a user name.
2. Log in to the system using your user name and password.
3. Disable the module using either ICS or TL1 commands. The example commands are for slot 3 in the main shelf.

ICS command:

Type `CONFIG 1A3 DISABLE`, then press **Enter**.

TL1 command:

`DISC-MODULE::S1A3:123;`

4. Loosen the captive screws located at the top and bottom of the module front panel.
5. Pull up on the top extractor and down on the bottom extractor to unseat the module from the connector on the backplane.
6. Slide the module out of the shelf.
7. Install a blank filler panel to cover the empty slot.
8. Remove the module from the registry using either ICS or TL1 commands:

ICS command:

Type `CONFIG 1A3 REMOVE`, then press **Enter**.

TL1 command:

`RMV-MODULE::S1A3:123;`

9. Verify that the module is not in the registry:

ICS command:

Type `CONFIG`, then press **Enter**.

TL1 command:

`RTRV-INV:::123;`

Installing the SDU-2000e

This section provides guidelines and procedures for installing and cabling the SDU-2000e expansion chassis to the SSU-2000e main chassis. Before proceeding with the SDU-2000e installation, ensure that the procedures in [Preliminary Procedures](#), on page 58, have been performed.

The SDU-2000e chassis occupies 500 mm of vertical space, has a depth of 229 mm, and a width of 431.8 mm. Included are 530 mm ETSI compatible rack mounting ears. Optional 480 mm rack mounting ears are available for 480 mm EIA racks and cabinets. The SDU-2000e may be mounted on either a standard ETSI mounting rack or 300 mm deep equipment cabinet.



Caution: To avoid excessive heat build-up resulting in equipment damage, ensure that there is at least 76 mm (2 RU) of free space below the chassis.

Rack Mounting the SDU-2000e

The front panel of the chassis mounts flush to the rack or at distances of 100.5 mm from the front of the rack. An SDU-2000e equipment cabinet mounting diagram is shown in [Figure 2-13](#). To install the SDU-2000e in the rack, perform the following:

1. Determine and locate the appropriate mounting brackets to be used.
2. Attach a mounting bracket to each side of the chassis by aligning two columns (three holes per column) of the bracket with the holes on the side of the chassis. Use the appropriate screws to attach the mounting bracket. Ensure that both brackets are attached at equal distances from the front of the unit.
3. Mount the chassis to the front of the rack rails using the appropriate number of screws and washers for the rack.

4. If you are not connecting additional Expansion shelves, verify that the Bus Termination Assembly is inserted into the last SDU Interface (J105) and last SDU Backup Clock (J106) of the main SDU-2000e shelf, see [Figure 2-14](#).



Caution: To maintain EMC compliance, use only properly shielded cabling on all telecom signal wiring, including I/O, clocks, and Ethernet connections. Ensure that connections are appropriately grounded.



Recommendation: To aid in viewing and when connecting cables, install the SDU-2000e chassis at eye level whenever possible.

Making Ground Connections

The procedures for making ground connections for the SDU-2000e are the same as for the SSU-2000e. Refer to [Making Ground Connections](#), on page 62, and follow the procedures for grounding the SDU-2000e.

Making Power Connections

The procedures for making power connections for the SDU-2000e are the same as for the SSU-2000e. Refer to [Making Power Connections](#), on page 62, and follow the procedures to connect power to the SDU-2000e.

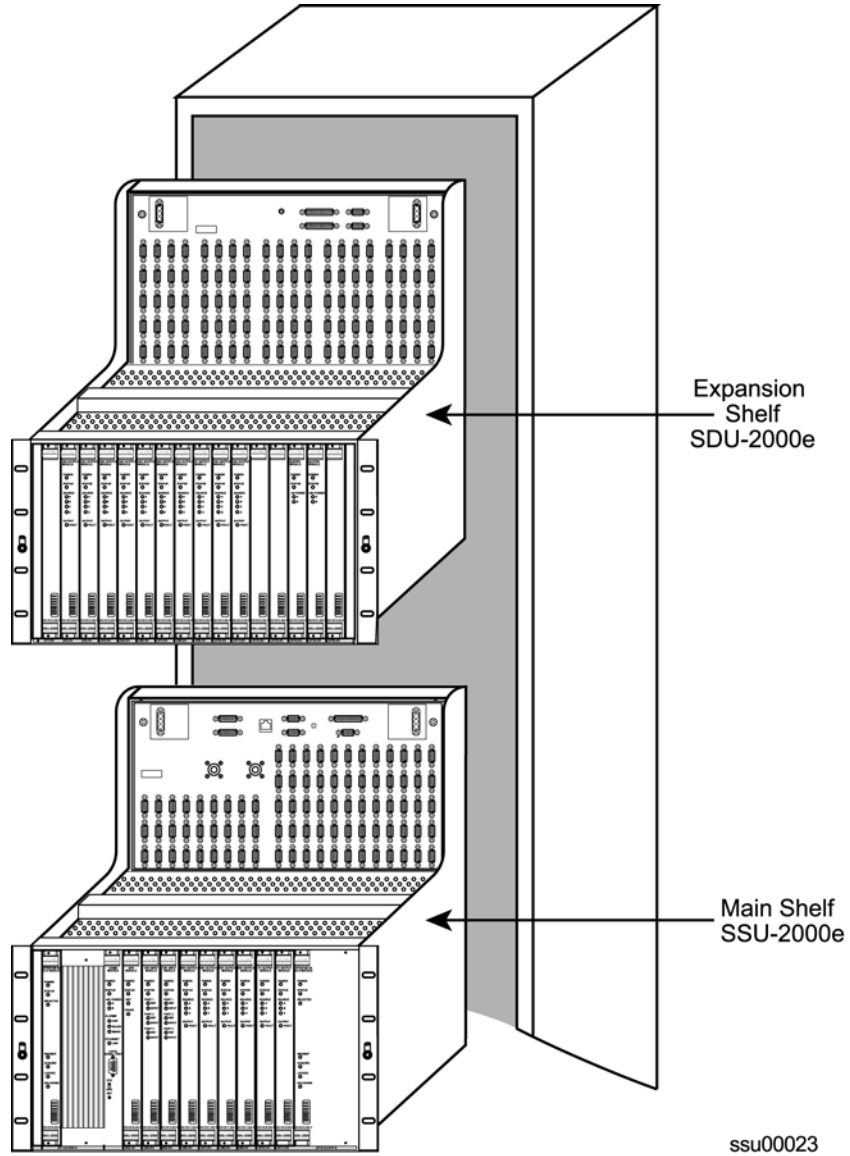

Figure 2-13. Equipment Mounting Cabinet

Connecting the Main Shelf

The SDU-2000e Expansion Chassis has interface connections on the front panel for connecting to an SSU-2000e Synchronous Supply Unit. Connections include the SDU Interface (J103 and J105) and the SDU Backup Clock Terminal (J104 and J106). [Figure 2-14](#) shows SDU-2000e expansion unit cabling.

SDU-2000e Interface Connector

Connection to the SSU-2000e is made through the SDU Interface Connectors. The SDU Interface Connections, J103 and J105, are 25 Pin D-Type female connectors with locking posts. The signals are differential pairs and connected in parallel. One connector is used to connect to a source unit, and the other is used for either a terminator or for feeding an additional SDU-2000e shelf. Up to four SDU-2000e shelves can be daisy-chained together. See [Figure 2-14](#) for expansion unit cabling.

[Figure 2-14](#) shows an SSU-2000e Expansion Terminator (part number 12013049-000-0). Install this terminator to the last expansion chassis in the daisy chain.

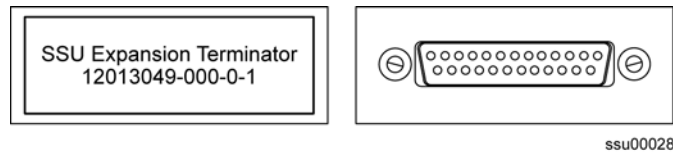

Figure 2-14. SSU-2000e Expansion Terminator

SDU Backup Clock Terminal

The SDU Backup Clock terminals (J104 and J106) are 9 pin D-type female connectors labeled SDU BACKUP CLK. They are connected in parallel. If the SDU is first in the daisy chain, J104 is used to connect to a source unit (SSU-2000e) and J106 is used to connect to an additional SDU-2000e shelf.

Install the backup clock terminator on the SDU BACKUP CLK connector J106 on the last expansion chassis in the daisy chain, see [Figure 2-15](#).

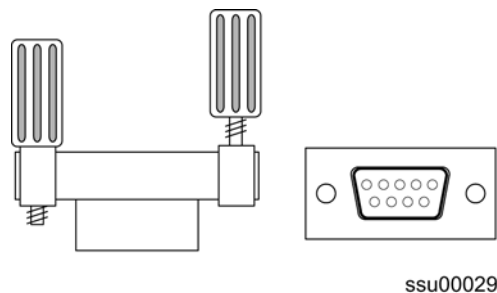
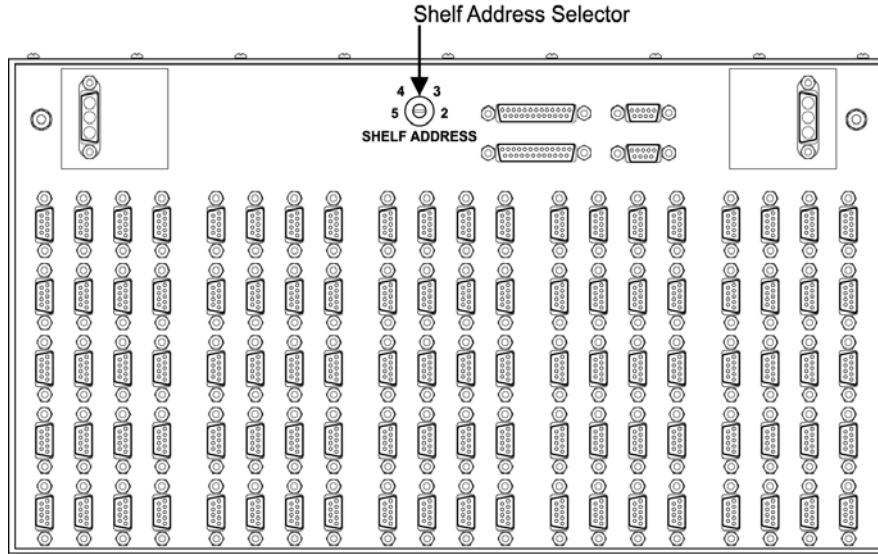

Figure 2-15. Backup Clock Terminator, Side and Front View

Setting the Shelf Address

Each SDU-2000e expansion chassis must be correctly configured for its position in the daisy chain. The shelf address selector is located on the top center of the expansion chassis connector panel, see [Figure 2-16](#). The settings range from 2 to 5. Using a common screwdriver, set the first expansion chassis to 2. If more expansion chassis are added, set them sequentially up to 5.



sdu00025

Figure 2-16. Shelf Address Selector

Connecting SDU Clock Outputs

The SDU-2000e Shelf has five groups of summed clock output connections on DE9P male connectors for connecting output telecom signals. There are twenty connectors in each group for a total of 100 outputs. The connectors in each group are arranged vertically in a five by four matrix and are labeled from top to bottom and left to right. Connections for group one are made using J1 through J20, connections for group two are made using J21 through J40, connections for group three are made using J41 through J60, connections for group four are made using J61 through J80, and connections for group five are made using J81 through J100.

Each connector is associated with a specific pair of output plug-in module slots, see [Table 2-9](#) below for the plug-in module slot connector relationship. The signal connections on these connectors are set up in differential pairs as Tip and Ring connections, see [Table 2-8](#).

Table 2-8. Clock Output DE9 Connector Pin Assignments

Pin	Signal
2	Tip
6	Ring
1	Sleeve
3,4,5, and 7-9	Unused

Table 2-9. Output Module Slot to Connector Relationship

Slot Label (Name)	Plug-in Module Slot	Group	Output Connector (Module Port) Reference Description
OUTPUT-1	A1	1	J1 (1) through J20 (20)
OUTPUT-2	A2		
OUTPUT-3	A3	2	J21 (1) through J40 (20)
OUTPUT-4	A4		
OUTPUT-1	A5	3	J41 (1) through J60 (20)
OUTPUT-2	A6		
OUTPUT-3	A7	4	J61 (1) through J80 (20)
OUTPUT-4	A8		
OUTPUT-5	A9	5	J81 (1) through J100 (20)
OUTPUT-6	A10		

Installing SDU Modules

The SDU-2000e shelf has 12 plug-in module slots located on the front of the chassis. The module slots are numbered from left to right looking at the front of the shelf, A1 through A12. Each module slot has a specific address defined in [Table 2-10](#) below. Each module slot has two hybrid DIN connectors associated with it on the backplane. The hybrid contacts of these connectors are used for power, logic ground, and frame ground connections. Each module slot has three pins connected together on each hybrid DIN connector which are used to detect module removal. Use the precautions in [Handling Modules](#), on page 73, when handling modules in the SDU-2000e. Install modules in the SDU-2000e using the procedures in [Installing a Module](#), on page 75.



Caution: To avoid damaging the shelf, never insert Output modules in slots A15 and A16. Insert only Buffer modules into these slots.

Table 2-10. Module Slot Addresses

Slot-A	Address	Module Types	Comments
1, 2	1, 2	Output, Pair 1	Paired Outputs
3, 4	3, 4	Output, Pair 2	Paired Outputs
5, 6	5, 6	Output, Pair 3	Paired Outputs

Table 2-10. Module Slot Addresses (Continued)

Slot-A	Address	Module Types	Comments
7, 8	7, 8	Output, Pair 4	Paired Outputs
9, 10	9, 10	Output, Pair 5	Paired Outputs
	11 - 14	Not Used	In ETSI SDU
	15 - 18	Not Used	Reserved for future I/O (23" shelf)
11, 12	19, 20	Buffers	Expansion Buffers
	0	All	Addresses all modules in the Shelf



Caution: To avoid equipment damage due to poor ventilation and EMI considerations, each slot in the SDU-2000e must contain either a module or blank filler panel. Filler panels are available from Symmetricom for unpopulated slots.

Installation Checklist

Perform the following steps to ensure that the SSU-2000e is correctly installed.

1. Unpack all equipment carefully and check it against the purchase order.
2. Ensure the SSU-2000e chassis is securely attached to mounting rack.
3. Ground the SSU-2000e chassis using the frame ground lug.
4. Measure between the ground and chassis and verify that no voltage exists.
5. If an SDU-2000e Expansion chassis is not being installed, ensure that the connectors J8 and J9 to the SSU-2000e are connected to a proper terminator.
6. Connect office alarms to the REMOTE and LOCAL terminals with 1.024 mm² wire.
7. Using proper handling techniques, insert modules and filler panels in appropriate slots.
8. Connect primary power to the A-BUS and secondary power to the B-BUS terminals by installing the appropriate 5-A fuse into the power supplies.
9. Measure the voltage at POWER A (and POWER B if used), and verify that it is between -38 VDC and -72 VDC (-48 VDC nominal).
10. Perform the procedures in [SSU-2000e Turn-Up Procedures](#), on page 85.

11. Verify that all modules are receiving power and generating regulated DC outputs by checking that their POWER indicators (LEDs) are lit, see [Normal System Indications During Turn-Up](#), on page 87.
12. To ensure that both power inputs are valid, verify that the green POWER indicator on the front of the Communications module is on. Also verify that the –48V Power A and B LEDs are both green. If all these indicators are not green, refer to [Table 2-11](#) for the LED color code indications. Refer to [Chapter 5, Maintenance and Troubleshooting](#), if you are unable to obtain the correct indications.

Table 2-11. Power LED Indications

LED	State	Indication
Power	On	At least one –48V power supply is connected
Power	Off	No –48V power supply A or B connected
–48V Power Supply A or B	On (Green)	Power supply is connected
–48V Power Supply A or B	Off	No –48V power supply connected to the inputs indicated by the LED
–48V Power Supply A or B	On (Amber)	Polarity is reversed on the inputs indicated by the LED

SSU-2000e Turn-Up Procedures

To power-up the shelf, insert 5-amp fuses, one each for Power A and Power B, into the appropriate slot in the power distribution control panel.

SSU-2000e Normal Indications During Turn-Up

As the shelf powers up and begins normal operation, the LEDs on the front of each of the installed modules go through a sequence as follows:

- **Clock Module 2E** – The POWER LED turns green when the fuses are installed in the main chassis and stays green. The STATUS LED blinks green and amber for approximately 10 to 15 seconds and then stays green. The SELECTED LED turns green on the selected clock module after the ACQUIRE LED on the clock module turns green. The WARMUP LED turns amber for approximately 30 seconds to 5 minutes then turns off and the ACQUIRE LED turns green. The ACQUIRE LED stays green 10 to 15 minutes until the module locks onto a signal, then the LED turns off. The LOCKED LED then turns green and stays green.

- **Clock Module 3E** – The POWER LED turns green when power is applied to the unit and stays green. STATUS LED blinks green and amber for approximately 10 to 15 seconds and then stays green. The SELECTED LED turns green on the selected clock module after the ACQUIRE LED turns green. The WARMUP LED turns amber for approximately 30 seconds to 20 minutes then turns off and ACQUIRE turns green. The ACQUIRE LED stays green until the module locks onto a signal (10 to 15 minutes); then the LED turns off. The LOCKED LED turns green and stays green.
- **Communications Module** – The POWER LED turns green when power is applied to the unit and stays green. The STATUS LED blinks green and amber for 10 to 15 seconds and then stays green. The –48V POWER LEDs A and B turn green to indicate that the power supplies are connected. If one of these LEDs are amber, the polarity of that power connection is reversed and needs to be switched. The three ALARM LEDs clear after approximately 1 minute. After initialization, if there are any alarms, it takes approximately 30 seconds to register and the ALARM LED turns amber. The ETHERNET LINK LED blinks green for approximately 30 seconds and stays green.
- **Input Module** – The POWER LED turns green when power is applied to the unit and remains green while the system is powered up. The STATUS LED blinks green and amber for approximately 10 to 15 seconds and then stays green. The PORT 1 REF LED blinks for approximately 5 to 10 seconds and turns green for the reference input and off for the others. The INPUT LED blinks for 5 to 10 seconds and turns green for every valid input or amber for invalid inputs.
- **Output Module** – The POWER LED turns green when power is applied to the unit and stays green. The STATUS LED blinks green and amber for 10 to 15 seconds and then stays green. The SOURCE LED turns green for the source clock, amber for an enabled clock that is not present and off for an enabled clock that is present (but not the source clock).

SDU-2000e Turn-Up Procedures

This section describes the procedures for powering up the SDU-2000e system and bringing the system on-line after completion of the system installation. After completing the turn-up procedures, perform the tests in [Commissioning the SDU 2000e](#), on page 126, to ensure that the system is functioning properly.

SDU-2000e Power Control

The SDU-2000e expansion chassis is *not* equipped with a Power switch. Power to the SDU-2000e is controlled by two external power supplies that provide –48/60 VDC to the SDU-2000e main chassis (A-BUS and B-BUS) at connectors J101 and J102. To power-up the shelf, install the fuses and/or turn the power on to both power supplies.

Normal System Indications During Turn-Up

As the system powers up and begins normal operation, the indicators on the front of all installed Output modules should go through the following sequence:

- The POWER indicator turns green when power is applied to the unit and stays green.
- The STATUS indicator blinks green and amber for approximately 10 to 15 seconds and then stays green.
- The SOURCE indicator turns green for source clock, amber for *not* source clocks, and off for non-existent clocks.

The POWER indicator and both –48/60 VDC indicators on the installed **Buffer modules** should turn green and stay green.

After Turn-Up

After completing the turn up procedures:

- Assign a System Administrator and any additional users to the system using the procedures in [Adding An Administrator User](#), on page 95.
- Make any required changes to the factory default configuration settings as described in [Chapter 3, Provisioning and Operating the SSU-2000e](#).
- Complete the commissioning tests in [Chapter 4, Commissioning the SSU-2000e](#), to ensure that the system is functioning properly.
- Refer to [Chapter 5, Maintenance and Troubleshooting](#) to clear any system alarms that might occur.

This completes the turn-up procedures. See [Chapter 3, Provisioning and Operating the SSU-2000e](#), for instructions on connecting to the SSU-2000e and assigning a system administrator and additional users (system is password protected). Then refer to [Chapter 4, Commissioning the SSU-2000e](#), for test procedures to ensure the system is functioning properly, or to [Chapter 5, Maintenance and Troubleshooting](#), to clear any persistent system alarms.

Chapter 3 Provisioning and Operating the SSU-2000e

This chapter provides operating instructions and software provisioning procedures for the SSU-2000e system.

In This Chapter

- [Controls and Indicators](#)
- [Establishing a Connection With the SSU-2000e](#)
- [Overview of the SSU-2000e Security System](#)
- [Adding An Administrator User](#)
- [Adding Users](#)
- [Setting Security Parameters](#)
- [Initial Provisioning](#)
- [Checking Alarm Status](#)
- [Factory Default \(Basic\) Configuration](#)
- [Backing Up the Configuration](#)
- [Restoring the Configuration](#)

Controls and Indicators

SSU-2000e Status LED Indicators

All modules used in the SSU-2000e main chassis and in the optional SDU-2000e expansion chassis contain status LED indicators that provide a visual indication of module status. The Communications module provides both system and individual module status whereas all other modules provide individual module status only. For more information on individual module status LED indicators, refer to [SSU-2000e Turn-Up Procedures](#), on page 85, and [Chapter 6, Clock and Communications Module Reference Data](#), [Chapter 7, Input Module Reference Data](#), and [Chapter 8, Output Module Reference Data](#).

SSU-2000e Operating Controls

The SSU-2000e contains three hardware operating controls:

- Two DCE/DTE select switches associated with the three EIA-232 ports. One switch is located on the front of the Communications module and the second switch (S1) is located on the SSU-2000e connection panel. The DTE position is for connection to a PC and the DCE position is for connection to a modem.
- Reset (RST) switch on the Communications module.

Establishing a Connection With the SSU-2000e

You can connect to the SSU-2000e using either a serial connection or an Ethernet connection. To connect via a serial port, see [Communicating by Serial Port](#), on page 91. If the SSU-2000e is connected to an Ethernet LAN, use the procedure described in [Communicating by Ethernet](#), on page 92. Refer to [Table 3-1](#) for the serial and Ethernet communications port assignments.

Table 3-1. Communications Port Assignments

Port #	Function	Protocol
Serial Ports (EIA-232)		
A (J4)	This port is user selectable as either an ICS or a TL1 interface. The port defaults to ICS upon initialization	ICS (Default), TL1
B (J5)	This port is user selectable as either an ICS or a TL1 interface. The port defaults to ICS upon initialization	ICS (Default), TL1
Local (Comms Module)	This port is user selectable as either an ICS or a TL1 interface. The port defaults to ICS upon initialization	ICS (Default), TL1

Table 3-1. Communications Port Assignments (Continued)

Port #	Function	Protocol
Ethernet Ports (Telnet)		
23	This port is user selectable as either an ICS or a TL1 interface. The port defaults to ICS upon initialization	ICS (Default), TL1
123	This port is designated for NTP only	NTP
161	This port is designated for SNMP Interactive	SNMP Interactive
162	This port is designated for SNMP Trap transmission	SNMP Trap
2000	This port is designated for TL1 only	TL1

Communicating by Serial Port

Three EIA-232-C ports are available on the SSU-2000e. Attach a PC with terminal emulation software to one of the ports as shown in [Figure 3-1](#) (this example shows a connection to the local port on the front of the Communications module).

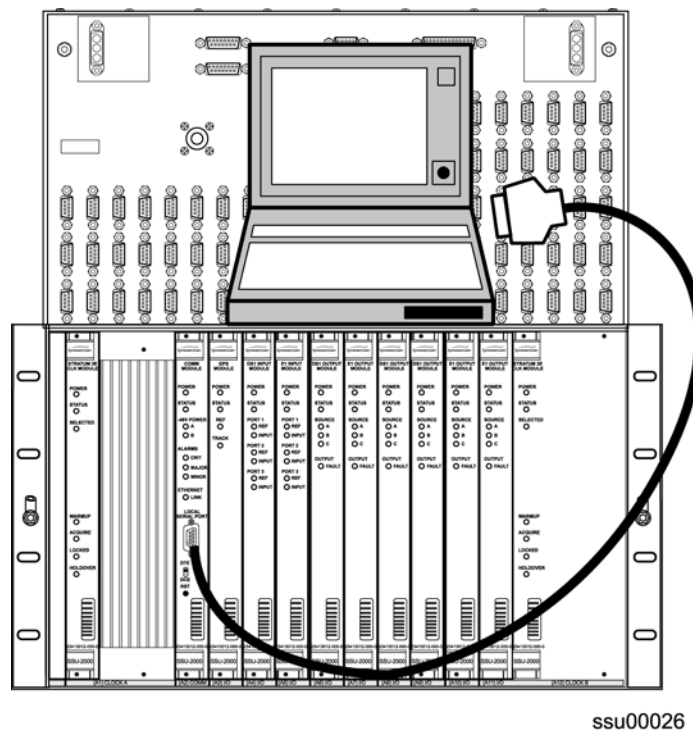

Figure 3-1. Direct Connection Using the Serial Port

1. Connect one end of the cable to the serial port on the computer or terminal and the other to the appropriate connector on the SSU-2000e.
2. Set the DTE/DCE switch S1 on the connection panel for the type of cable (straight-through or modem).
3. Configure the emulation software for 8 data bits, no parity, 1 stop bit, and 9600 baud rate.
4. Start the terminal emulation software and press **Enter**. The system prompt -> should appear. If it does not, recheck each step in this procedure.
5. For the initial installation, create an Administrator-level user as described in [Adding An Administrator User](#), on page 95, before proceeding with the Ethernet setup.

Communicating by Ethernet

To communicate with the SSU-2000e using an Ethernet LAN, you must first configure the Ethernet port. This section describes how to configure the Ethernet port and then connect to the SSU-2000e using the Ethernet port.

When you connect to the SSU-2000e via Ethernet port 2000 (decimal) using a Telnet-type application, the session opens in TL1 mode. Up to four sessions (users) can be connected to port 2000 at one time. Once you are connected, you must log in using the ACT-USER command with a user name and password (if security is active on the unit).

To log off the user and exit from an Ethernet session, type `CANC-USER:::0;`. Another user can then open a new session by using the ACT-USER command.

To log off the user, exit from an Ethernet session, and close the Ethernet connection to port 2000, type `EXIT:::0;`. The next user must first connect to port 2000 and then log in using the ACT-USER command.

Configuring the Ethernet Port

Use the following procedures to configure the SSU-2000e Ethernet parameters (IP Address, Subnet Mask, and Gateway Address).

1. Establish a direct serial connection to the SSU-2000e as described in [Communicating by Serial Port](#), on page 91.
2. Provision the IP, Gateway, and Subnet addresses for the SSU-2000e. The IT department or site administrator for your location can recommend specific addresses for these parameters. Use the format xxx.xxx.xxx.xxx to enter the address parameter.

ICS commands:

Type `IP ADDR [ip address]`, then press **Enter**.

Type `IP GATEWAY [gate address]`, then press **Enter**.

Type `IP SUBNET [subnet address]`, then press **Enter**.

TL1 command:

```
SET-PRMTR-IP:::123::[ip address],[gate address],[subnet address];
```

3. Restart the Communications module:

ICS command:

Type `restart 1A02`, then press **Enter**.

TL1 command:

```
RST-MODULE::S1A2:123;
```

4. Verify that the information is correct:

ICS command:

Type `ip`, then press **Enter**.

TL1 command:

```
RTRV-PRMTR-IP:::123;
```

Connecting through the Ethernet LAN

After the Ethernet port is configured, use the following procedure to connect to it:

1. Ensure that the SSU-2000e is connected to a LAN. See [Making Ethernet Connections](#), on page 65 for details.
2. Telnet from your PC to the IP address assigned to the SSU-2000e.
3. Type your user name and press the **Enter** key. If you are not assigned as a user in the system, contact the System Administrator for your SSU-2000e.
4. Enter your assigned password and press **Enter**. The system prompt appears.

Overview of the SSU-2000e Security System

The operating software of the SSU-2000e includes a subset of GR-815 security requirements, including user lockout, password aging, and login failure attempts. New commands allow an Administrator-level user to query the security log, set the login failed attempts threshold, set user lockout timer, and set the password-aging timer. New commands also allow you to back up and restore the configuration in the shelf. See the *SSU-2000e Technical Reference* for details on the security commands.

Passwords must have at least one alphanumeric, one numeric, and one special (punctuation, for example) character. The password can be up to 10 characters long. The user must create a new password after the specified password aging period has elapsed; the new password cannot be the same as any of the previous three passwords. The user must confirm entry of a new password by re-typing the password.

If a user fails to enter a correct password in a preset number of attempts, that user is locked out from further attempts to log in for a specified amount of time, and an entry is made in the security log. An Administrator-level user can set the number of attempts, the lock-out period, and password aging.

A security log maintains a record of each login attempt, successful logins, and log-outs. Other events stored in the log including adding and changing users, changes to a user's profile (password and/or access level), enabling and disabling a user, or changes to the password aging period. The log records the date and time of each entry, the user ID, and the session type. Passwords are not stored in the security log. This log is stored in non-volatile memory, and cannot be modified or deleted by any user.

In order to use the security features, the hardware and firmware in the SSU-2000e must be as shown in [Table 3-2](#).

Table 3-2. Firmware Requirements for Security Features

Module	Module Part Number	Hardware Revision Required ^a	Firmware Code Part Number
Communications module	23413012-00x-0	A.00 or higher	14313012-000-5 Rev. M.00
Clock modules	23413015-00x-0 23413016-000-0	A.00 (JCC: B.00) or higher A.00 (JCC: A.10) ^b or higher	14313015-000-5 Rev. M.00

Note:

^a The hardware revision is on a label located on the front panel. You can display the hardware revision by issuing the TL1 command RTRV-INV, or the ICS command CONFIG.

^b Japan Composite Clock

The SSU-2000e system software allows you to set up a list of users with one of five access levels; each level has an increasing level of access to system functions and commands. Each incremental access level incorporates all of the options from the lower numbered access levels and additional options at that level. For instance, a User-level user does not have as many options available as a Technician-level user.

An Administrator-level user assigns the access level to each user when the user id and password is created. [Table 3-3](#) summarizes each access level, ID number, and the operator privileges for each level.

Table 3-3. User Access Levels

Level	ID	Description
Idle	0	Access level 0 is available when no user is logged in. This level allows Idle-level users to view a list of available commands (HELP), syntax, software version number, unit id, or to login.
User	1	Users at the User level can execute level 0 commands and view information about the current configuration and operation, and change communication settings such as line termination and echo. Changes made by a User-level user remain in effect only until the user logs out.
Technician	2	Users at the Technician level (CRAFT persons) can perform levels 0 through 1 functions, and can read or set all installation functions.
Supervisor	3	Supervisor-level users can execute all commands at levels 0 through 2, and can read or set all functions.
Administrator	4	Administrator-level users can execute all levels of commands; they can view and set software configurations; they can also add, delete, or modify the user table, or log off any user from any port.

Adding An Administrator User

You must add an Administrator-level user to the user list when you log in for the first time. The Administrator user performs initial setup and can assign user privileges and access codes as needed, as well as configure all system parameters. Refer to [Overview of the SSU-2000e Security System](#), on page 93, for more information on user access levels.



Caution: You must add the administrator user and password before adding any other users. If you add a user that is not at the administrator security level before adding the administrator, you will not be able to log into the unit at that level again without a service call.

Perform the following steps to add an Administrator-level user to the system.

1. Connect a computer to the SSU-2000e using the procedure in [Communicating by Serial Port](#), on page 91. The `SSU-2000e>` prompt appears.
2. Type `admin` at the username prompt for the first-time system login (otherwise enter your username) and press **Enter**. The system prompts for a password.
3. Press the **Enter** key for the first-time system login (otherwise enter your password and press **Enter**). The system prompt appears.
4. Type `user add` and press **Enter**. The system prompts you for a username.

5. Enter a “username” and press **Enter**. The name you enter will be the log-in name for the system administrator. You can use up to 20 characters for the user name. The system prompts you for a password.
6. Enter a “password” and press **Enter**. Passwords must have at least one alphanumeric, one numeric, and one special (punctuation, for example) character. The password can be up to 10 characters long. The password you enter will be the log-in password for the system administrator. The system prompts you to confirm the password by retyping it.
7. Retype the password and press **Enter**. The system prompts for an access level.
8. Type 4 and press **Enter**. This selects the administrator access level. The system prompt appears.
9. Type `bye` and press **Enter** to log off the system.
10. Type `login` followed by the administrator’s user name and password and press **Enter**. This verifies that the account exists.
11. Type `bye` and press **Enter** to log off the system.

Adding Users

Only an Administrator-level user can add new users to the SSU-2000e user list. You can use ICS or TL1 commands.

Using ICS Commands

1. Connect a computer to an ICS port on the SSU-2000e and log in using an Administrator-level user name and password, as described in [Logging In to the SSU-2000e](#), on page 102.
2. Type `USERS ADD` then press **Enter** to create a new user account. The system prompts for the new username.
3. Type in the new username, then press **Enter**. You can use up to 20 characters for the username. The system prompts for the new user’s password.
4. Type in the new user’s password and press **Enter**. Passwords must have at least one alphanumeric, one numeric, and one special (punctuation, for example) character. The password can be up to 10 characters long. The system prompts you to confirm the password by retyping it.
5. Type in the new user’s password and press **Enter**. The system prompts for an access level.

6. Type in the new user's access level (a number between 1 and 4, inclusive), and press **Enter**. The following text shows the dialog for creating a new level-1 user with the name david1:

```
SSU_2000e->users add
Username: DAVID1
Password: *****
Confirm:  *****
Access:    1
2006-02-22T16:49:55  1A02 Rep Add User, DAVID1, TELA
SSU_2000e+>
```

7. Type `users` and press **Enter** to display the user table. The system responds with a list similar to the following:

```
2006-02-23T22:01:45  ID: SSU2000e, Name: SSU_2000e
Password Aging: Enable
User Lockout:      Enable
```

User Name	Level	User	Password	DaysLeft	Lock
ADMIN	4	ENA	ALIVE	23	NO
DAVID	4	ENA	ALIVE	28	NO
DAVID1	1	ENA	ALIVE	29	NO

```
SSU_2000e->
```

Using TL1 Commands

1. Connect a computer to port 2000 on the SSU-2000e and log in using an Administrator-level user name and password, as described in [Logging In to the SSU-2000e](#), on page 102.
2. Type `SET-USER:::123::ADD,FRANK1,ABC123!,1;` to add a user named FRANK1 with a password of ABC123! at the User level. The system responds with:

```
SSU_2000e 06-02-21 20:07:21
M 123 COMPLD
"\PASSWORD CONFIRMATION REQUIRED, SET-PWD-CONFIRM\" "
;
```

3. Type `SET-PWD-CONFIRM:::123::ABC123!;` to confirm the new password. You *must* issue the SET-PWD-CONFIRM command immediately after the SET-USER command in order to validate the SET-USER command. The system responds with:

```
SSU_2000e 06-02-21 20:21:41
A 000001 REPT EVT
"S1A02:NA,193,NSA,06-02-21,20-21-41:\Add User, FRANK1,
TL1B\" "
;
```

4. Type `RTRV-USER:::123;` to display a list of users in the system. The system responds with:

```
SSU_2000e 06-02-22 14:32:40
M 123 COMPLD
"ADMIN,4,ENA,ALIVE,23,NO"
"DAVID,4,ENA,ALIVE,28,NO"
"DAVID1,1,ENA,ALIVE,29,NO"
"FRANK1,1,ENA,ALIVE,29,NO"
;
```

where the format for the list of users is `username, level, password State, password days left, lockout`.

Setting Security Parameters

Only an Administrator-level user can access security parameters for the SSU-2000e. You can use ICS or TL1 commands to set the security parameters, which include the following:

- Setting the Number of Failed Attempts Counter – if a user cannot log in correctly within this number of attempts, that user is then prevented from further attempts for the period specified in the Lockout time parameter.
- Setting the Lockout Time – When a user has exceeded the number of failed login attempts, that user is prevented from further attempts to log in for the period specified in this parameter.
- Setting the Password Aging – A user's password is valid for the number of days specified in this parameter. If the user attempts to log in after this number of days, the user must create a new password.
- Viewing the Security Log – The security log contains information related to the security of the system, such as the login attempts, successful logins, logouts, etc.
- Setting User Parameters, such as:
 - Changing a Password
 - Changing Access Level
 - Deleting a User
 - Setting a Temporary Password
 - Enabling, Disabling, and Unlocking Users

Using ICS Commands

1. Connect a computer to a serial port on the SSU-2000e and log in using an Administrator-level user name and password, as described in [Logging In to the SSU-2000e](#), on page 102.
2. Type `SECURITY FAIL 3` and press **Enter** to set 3 as the number of failed login attempts before disabling the user account.
3. Type `SECURITY LOCKOUT 60` and press **Enter** to set the lockout time to 60 seconds.

4. Type `SECURITY AGING 30` and press **Enter** to set the password to expire in 30 days.
5. Type `SECURITY LOG 10` then press **Enter** to display the last 10 entries in the Security log. The log appears as shown:

```
SSU_2000e->security log 10
2006-02-22T18:41:29 ID: SSU2000, Name: SSU_2000e
Time Stamp          Description          Information
-----
2006-02-22T17:11:04 LOGIN              ENET, TL1, DAVID1
2006-02-22T17:12:18 CHANGE_PASSWORD   ENET, TL1, DAVID1
2006-02-22T17:16:34 LOGIN_FAIL        ENET, TL1, ADMIN
2006-02-22T17:21:20 LOGOUT            ENET, TL1, DAVID1
2006-02-22T17:31:48 LOGIN_FAIL        ENET, TL1, ADMIN
2006-02-22T17:47:01 LOGIN_FAIL        ENET, TL1, ADMIN
2006-02-22T18:02:10 LOGIN_FAIL        ENET, TL1, ADMIN
2006-02-22T18:17:19 LOGIN_FAIL        ENET, TL1, ADMIN
2006-02-22T18:32:32 LOGIN_FAIL        ENET, TL1, ADMIN
2006-02-22T18:41:24 LOGIN              ENET, ICS, DAVID
SSU_2000e->
```

Changing a User's Password

1. Type `USERS PWD` then press **Enter** to change a password. The system prompts for the user name that is to receive the new password.
2. Type the user name, then press **Enter**. The system prompts for the new password.
3. Type the new password, then press **Enter**. The system prompts you to confirm the new password.
4. Retype the new password, then press **Enter**. If you do not type the new password exactly the same, the command fails.

Setting a Temporary Password

An Administrator-level user can create a temporary password for a user. When a user logs in using the temporary password, that user must create a new password before continuing.

1. Type `USERS TEMPPWD` then press **Enter** to create a temporary password. The system prompts for the user name that is to receive the new password.
2. Type the user name, then press **Enter**. The system prompts for the password.
3. Type the new password, then press **Enter**. The system prompts you to confirm the password.
4. Retype the new password, then press **Enter**. If you do not type the new password exactly the same, the command fails.

Changing a User's Access Level

1. Type `USERS ACCESS` then press **Enter** to change a user's access level. The system prompts for the user name that is to receive the new access level.
2. Type the access level (1 through 4), then press **Enter**.

Deleting a User

1. Type `USERS DEL` then press **Enter** to delete a user from the user table. The system prompts for the user name that you want to delete.
2. Type the user name, then press **Enter**. The system deletes the user from the user table.

Enabling, Disabling, and Unlocking Users

An Administrator-level user can enable or disable a user from accessing the SSU-2000e without removing the user name from the user table. If a user exceeds the number of failed attempts to log in, then the user name is locked for a period of time. An Administrator-level user can unlock the user name and allow the user to attempt to log in, overriding the Lockout Time parameter.

1. Type `USERS DISABLE` then press **Enter** to disable a user from accessing the SSU-2000e. The system prompts for the user name that you want to disable.
2. Type the user name, then press **Enter**. The system disables the user.
3. Type `USERS ENABLE` then press **Enter** to allow a user to access the SSU-2000e. The system prompts for the user name that you want to enable.
4. Type the user name, then press **Enter**. The system enables the user.
5. Type `USERS UNLOCK` then press **Enter** to unlock a user name. The system prompts for the user name that you want to unlock.
6. Type the user name, then press **Enter**. The system unlocks the user.

Using TL1 Commands

1. Connect a computer to port 2000 on the SSU-2000e and log in using an Administrator-level user name and password, as described in [Logging In to the SSU-2000e](#), on page 102.
2. Type `SET-PRMTR-SECU:::123::3,60,60;` to set to 3 the number of failed login attempts before disabling the user account, to set the lockout time to 1 minute, and to set the password to expire in 60 days. The system responds with:

```
SSU_2000e 06-02-21 20:27:35
A 000002 REPT EVT
  "S1A02:NA,215,NSA,06-02-21,20-27-35:\"Security, Lockout, 60, TL1B\" "
;
```

3. Type `RTRV-SEC-LOG:::123::10;` to display the 10 most recent security log events.

Changing a User's Password

1. Type `SET-USER:::123::PWD,username,password;` to change the password for the specified user.
2. Type `SET-PWD-CONFIRM:::123::password;` to confirm the new password. You *must* issue the SET-PWD-CONFIRM command immediately after the SET-USER command in order to validate the SET-USER command.

Setting a Temporary Password

An Administrator-level user can create a temporary password for a user. When a user logs in using the temporary password, that user must create a new password before continuing.

1. Type `SET-USER:::123::TMP,username,pwd;` to create a temporary password for the specified user.
2. Type `SET-PWD-CONFIRM:::123::pwd;` to confirm the temporary password. You *must* issue the SET-PWD-CONFIRM command immediately after the SET-USER command in order to validate the SET-USER command.

Changing a User's Access Level

Type `SET-USER:::123::ACC,username,,level;` to change the access level for the specified user.

Deleting a User

Type `SET-USER:::123::DEL,username;` to delete the specified user from the user table.

Enabling, Disabling, and Unlocking Users

An Administrator-level user can enable or disable a user from accessing the SSU-2000e without removing the user name from the user table. If a user exceeds the number of failed attempts to log in, then the user name is locked for a period of time. An Administrator-level user can unlock the user name and allow the user to attempt to log in, overriding the Lockout Time parameter.

1. Type `SET-USER:::123::DIS,username;` to disable the specified user from accessing the SSU-2000e.
2. Type `SET-USER:::123::ENA,username;` to allow a user to access the SSU-2000e.
3. Type `SET-USER:::123::UNL,username;` to unlock a user name.

Logging In to the SSU-2000e

Using ICS Commands

1. Connect a computer to a serial port on the SSU-2000e using the procedure in [Establishing a Connection With the SSU-2000e](#), on page 90. A prompt to enter a username appears.
2. Type your user name (or use `ADMIN`, the default Administrator-level user name) then press **Enter**. The system prompts for a password.
3. Type your password (or use `SSU-2000`, the default password) then press **Enter**. The following text appears followed by the system prompt, showing that you have access to the system.

```
pSOSystem (172.16.21.19)

Username: ADMIN
Password:
Symmetricom Technical Support
1-888-367-7966 toll free USA
1-408-428-7907 worldwide
SSU_2000e, 2006-02-23T21:49:32 DOY:54
14313012-005-5, F.00, 02FEB06

!!!!!!!!!!!!!!!!!!!!!!!!!!!!!!!!!!!!!!!!!!!!!!!!!!!!!!!!!!!!!!!!!!!!!!
NOTICE: THIS IS A PRIVATE COMPUTER SYSTEM.
UNAUTHORIZED ACCESS OR USE MAY LEAD TO PROSECUTION.
!!!!!!!!!!!!!!!!!!!!!!!!!!!!!!!!!!!!!!!!!!!!!!!!!!!!!!!!!!!!!!!!!!!!!!

SSU_2000e->
```

Using TL1 Commands

1. Connect a computer to port 2000 on the SSU-2000e using the procedure in [Establishing a Connection With the SSU-2000e](#), on page 90.
2. Press the `;` key to ensure you have a connection. With an active connection, the system responds with a DENY message:

```
SSU_2000e 06-02-23 21:54:06
M 0 DENY
IITA
;
```

3. Type `ACT-USER::username:123::pwd;` to log in to your account, where `username` is your user name and `pwd` is your password, or type `ACT-USER::admin:123::SSU-2000e;` to log in, where `ADMIN` is the default user name and `SSU-2000` is the default password. The following text appears followed by the system prompt, showing that you have access to the system.

```
SSU_2000e 06-02-23 21:54:35
```

Logging Off of the SSU-2000e

Use one of the following commands to log off of the SSU-2000e:

Using ICS commands

Type `bye` and press **Enter**.

Using TL1 commands

`CANC-USER:::123;`

Initial Provisioning

After you have established communications with the SSU-2000e, you must provision the unit so it can track the input signals and start generating outputs. This sections contains general instructions for initial provisioning of the SSU-2000e, and are not intended to cover all combinations of Input and Output modules. You may need to alter the commands in this section to match the configuration of your SSU-2000e.

Provisioning General Parameters

This section describes how to provision the reference mode and the auto-return mode, set the IP address, and name the unit.

1. Log into the SSU-2000e using the procedure in [Logging In to the SSU-2000e](#), on page 102.
2. Provision the reference selection mode. The default is Priority, which is the most widely used mode. See [Selecting the Input](#), on page 25, for information on selecting the appropriate mode.

ICS command:

Type `REF PRI`, then press **Enter**.

TL1 command:

`SET-INPUT-REF:::123::port , PRI;`

where `123` is an arbitrary ctag value and `port` is the selected input port in the format `S1Ax[-z]`, where `x` is the slot number (3–12) and `z` is the port (1–3).

Repeat this command for all inputs.

3. Provision the clocks to enable auto-return (revertive) mode. Symmetricom generally recommends that auto-return be set to On, unless both clocks are of the same Stratum level. See [Selecting the Input](#), on page 25, for more information on revertive and non-revertive modes.

ICS command:

Type `CLK AR ON`, then press **Enter**.

TL1 command:

```
SET-CLK-AR:::123::ON;
```

4. Assign a name, if desired, to the SSU-2000e. You can assign a `[name]` of up to 20 characters, starting with a letter; the name is returned as the `tid` in responses from the unit.

ICS command:

Type `NAME [name]`, then press **Enter**.

TL1 command:

```
SET-NAME:S1A2:::123::[name];
```

You can also use this command to assign a name to inputs and outputs by specifying the module address the format `SyAx[-z]`, where `y` is the shelf number, `x` is the slot number, and `z` is the port.

Adding or Enabling a Module

Use this procedure when replacing one type of module with a different type of module in the same slot. The following example procedure adds a Clock module to shelf 1, slot 12.

1. Insert the module into slot 12 of the main shelf.
2. Log into the SSU-2000e using the procedure in [Logging In to the SSU-2000e](#), on page 102.
3. Enable the module:

ICS command:

Type `config 1A12 enable` and press **Enter**.

TL1 command:

```
ACT-MODULE::S1A12:123;
```

4. Verify that the module is registered:

ICS command:

Type `config` and press **Enter**.

TL1 command:

```
RTRV-INV:::123;
```

5. Log off the SSU-2000e when you're finished.

Disabling a Module

Use this command to temporarily disable a module without removing it from the system. The following example procedure disables the module in shelf 1, slot 12.

1. Log into the SSU-2000e using the procedure in [Logging In to the SSU-2000e](#), on page 102.

2. Disable the module:

ICS command:

Type `config 1A12 disable` and press **Enter**.

TL1 command:

`DISC-MODULE::S1A12:123;`

3. Log off the SSU-2000e when you're finished.

Removing a Module

Use this procedure to permanently remove a module from the system. If a module has been unplugged from the system, this command can also be used to clear the module's active alarms. The following example procedure removes the B Clock module in shelf 1, slot 12 from the registry.

1. Log into the SSU-2000e using the procedure in [Logging In to the SSU-2000e](#), on page 102.

2. Remove the module from the database:

ICS command:

Type `config 1A12 remove` and press **Enter**.

TL1 command:

`RMV-MODULE::S1A12:123;`

3. Verify that the module is not in the registry:

ICS command:

Type `config` and press **Enter**.

TL1 command:

`RTRV-CONF::1A12:123;`

4. Log off the SSU-2000e when you're finished.

Provisioning GPS Input Modules

This section describes how to enable GPS Input modules, if they are installed. You must enable each module and assign a priority level to each module. You can install GPS Input modules only in slot 3 and slot 5 of the main SSU-2000e shelf.

1. Log into the SSU-2000e using the procedure in [Logging In to the SSU-2000e](#), on page 102.

2. Enable the modules:

ICS command:

Type `INPUT 1A3 ENABLE`, then press **Enter**.

Type `INPUT 1A5 ENABLE`, then press **Enter**, if a module is present in slot 5.

TL1 command:

See the command in step 2, below.

3. Set the priority level for each module:

ICS command:

Type `INPUT 1A3 PRI 1`, then press **Enter**.

Type `INPUT 1A5 PRI 1`, then press **Enter**, if a module is present in slot 5.

TL1 command:

```
SET-PRMTR-INPUT::S1A3:123::ON,1;
```

enables the module in slot 3 and sets its Priority to 1.

```
SET-PRMTR-INPUT::S1A5:123::ON,1;
```

enables the module in slot 5 and sets its Priority to 1.

4. Provision the MTIE limits for each input port according to ITU (G.811 or G.823) or ANSI (PRS or DS1) specifications.

ICS command:

Type `INPUT 1Ay MTIE PRS|DS1|G.811|G.823` then press **Enter**

where y is slot number 3 or 5.

TL1 command:

```
SET-PRMTR-MTIE::S1Ay:123::{EL1|EL2|CL1|CL2},{t10},{t100},  
[t1k],[t10k],[t100k];
```

where y is slot number 3 or 5 and alarm thresholds EL1 or EL2 and the clear thresholds CL1 or CL2. Threshold settings t10 through t100k are the error limits in nanoseconds for the measurement time period.

Provisioning Other Input Modules

This section describes how to enable and provision other types of Input modules such as DS1, E1, or Composite Clock. You must enable and provision each input port as appropriate for the input signal. You can install these Input modules in any slot in the main SSU-2000e shelf.

1. Log into the SSU-2000e using the procedure in [Logging In to the SSU-2000e](#), on page 102.

2. Enable the modules:

ICS command:

Type `INPUT xAy-z ENABLE`, then press **Enter** where x is the shelf number, y is the slot number, and z is the port number. Repeat this command for each port and each slot.

TL1 command:

See the command in step 3, below.

3. Set the priority level for each port. Set the input Priority to a value from 0 to 10; 0 indicates that the port is Monitor-only and is never selected as a reference signal. 1 is highest priority, and 10 is lowest.

ICS command:

Type `INPUT lAy-z PRI [pri]`, then press **Enter** where y is the slot number, z is the port number, and [pri] is the priority value. Repeat this command for each port and each slot.

TL1 commands:

`SET-PRMTR-INPUT::S1Ay[-z]:123::ON,[pri];`
where y is the slot number and z is the port number. This command sets the Priority to the value (1–10) you enter. Repeat this command for each port and slot.

`SET-PRMTR-CCINP::S1Ay[-z]:123::ON,[pri];`
for Composite Clock Input modules, This command enables the module (y) and port (z) and sets its Priority to the value (1–10) you enter. Repeat this command for each CC Input port and slot.

4. Disable all slots and/or ports with no connected input signal to prevent spurious alarms.

ICS command:

Type `INPUT lAy-z DISABLE` then press **Enter**, where y is the slot number and z is the port number. Repeat this command for each unused slot and port.

TL1 command:

`SET-PRMTR-INPUT::S1Ay[-z]:123::OFF;`
where y is the slot number and z is the port number. Repeat this command for each unused port and slot.

5. Set the framing type for each input port. Provision DS1 signals to either ESF or D4; provision E1 signals to CAS or CCS.

ICS command:

Type `INPUT 1Ay-z FRAME ESF|D4`, then press **Enter** where y is the slot number and z is the port number. Select either ESF or D4 as appropriate. Repeat this command as needed for each slot and port.

TL1 command:

See Step 8, below.

6. Provision the Zero Suppress for each input port to On or Off as appropriate.

ICS command:

Type `INPUT 1Ay-z ZS ON|OFF`, then press **Enter** where y is the slot number and z is the port number.

TL1 command:

See Step 8, below.

7. Provision the Cyclic Redundancy Check (CRC) for each input port to On or Off.

ICS command:

Type `INPUT 1Ay-z CRC ON|OFF` then press **Enter** where y is the slot number and z is the port number.

TL1 command:

See Step 8, below.

8. Provision the Synchronization Status Message (SSM) for each input port to On or Off. When set to On, the SSU-2000e reads and interprets the SQL on the reference. If the reference does not include an SSM, the SQL is defined as STU.

ICS command:

Type `INPUT 1Ay-z SSM ON|OFF` then press **Enter**, where y is the slot number and z is the port number.

For E1 signals, you must define the bit position:

Type `INPUT 1Ay-z SSM [4-8]` then press **Enter**.

TL1 command:

```
SET-PRMTR-INPUT::S1Ay[-z]:123::,,ESF|D4|CCS|CAS|1|1.544|  
2.048|5|10,ssm,zs,crc,,bit;
```

where y is the slot number and z is the port number and the numbers indicate the input frequency in mega Hertz; ssm, zs, and crc are ON or OFF, as appropriate. Bit indicates the position (4–8) of the SSM in E1 signals.

9. Provision the MTIE limits for each input port according to ITU (G.811 or G.823) or ANSI (PRS or DS1) specifications.

ICS command:

Type `INPUT 1Ay-z MTIE PRS|DS1|G.811|G.823` then press **Enter** where y is the slot number and z is the port number.

TL1 command:

```
SET-PRMTR-MTIE::S1Ay[-z]:123::{EL1|EL2|CL1|CL2},{t10},{t100},  
[t1k],[t10k],[t100k];
```

where y is the slot number and z is the port number and alarm thresholds EL1 or EL2 and the clear thresholds CL1 or CL2. Threshold settings t10 through t100k are the error limits in nanoseconds for the measurement time period.

10. Assign a name, if desired, to each input port. You can assign a name of up to 20 characters.

ICS command:

Type `IONAME xAy [name]` then press **Enter**, where x is the slot number and y is the port number.

TL1 command:

```
SET-NAME::123:SxAy:name;
```

Provisioning Output Modules

This section describes how to enable and provision Output modules, such as DS1, E1, or Composite Clock. You must enable and provision each output port as appropriate. You can install Output modules in any I/O slot in the main SSU-2000e shelf and in the SDU-2000e Expansion Shelf.

1. Log into the SSU-2000e using the procedure in [Logging In to the SSU-2000e](#), on page 102.
2. Enable the modules:

ICS command:

Type `OUTPUT xAy-z ENABLE`, then press **Enter** where x is the shelf number, y is the slot number and z is the port number. Repeat this command for each slot and port.

TL1 command:

```
SET-PRMTR-OUTPUT::SxA[y[-z]]:123::ON;
```

where x is the shelf number, y is the slot number, and z is the port number. Repeat this command for each shelf, port, and slot.

3. Provision the Output module as appropriate.

ICS command:

Refer to the OUTPUT command description in the *SSU-2000e Technical Reference* for details on all command options.

TL1 command:

Refer to the SET-PRMTR-OUT commands for the various Output modules in the *SSU-2000e Technical Reference*.

4. Disable unused output ports to prevent spurious alarms. Repeat this command for each shelf, port, and slot.

ICS command:

Type OUTPUT xAy-z DISABLE, then press **Enter**
where x is the shelf number, y is the slot number, and z is the port number.

TL1 command:

SET-PRMTR-OUTPUT::SxAy[-z]:123::OFF;
where x is the shelf number, y is the slot number, and z is the port number.

5. If a DS1 input signal is not available, bypass the Clock C source for all output modules.

ICS command:

Type OUTPUT BYPASS OFF, then press **Enter**.

TL1 command:

SET-PRMTR-OUTPUT::SxAy[-z]:123::,, ,OFF;
where x is the shelf number, y is the slot number, and z is the port number.
Repeat this command for each shelf and Output module.

6. You can manually set the output SSM for a module, overriding the SSM set by the input:

ICS command:

Type OUTPUT xAy PQL pql, then press **Enter**.

TL1 command:

SET-OUT-PQL::SxAy:123::pql;
where x is the shelf number, y is the slot number, and pql is 0 - 16.

Saving the Provisioning Setup

After you provision each module, you can save the setup in the Communications module memory.

ICS command:

Type SET SAVE, then press **Enter**.

TL1 command:

SET-PRMTR-SETUP::ALL:123::SAVE;

Checking Alarm Status

All alarm indication lights should be extinguished and the POWER indication lights should be green after completing the power up sequence. The valid input reference alarm clears, rubidium lock clears, frequency alarms clear, and the ACQUIRE LED is ON. Use the following procedure to verify that the unit is operational.

1. Log into the SSU-2000e using the procedure in [Logging In to the SSU-2000e](#), on page 102.
2. Verify that there are no active alarms:

ICS command:

Type `alarm` and press **Enter**

TL1 command:

`RTRV-ALM: :ALL;`

3. Log off the SSU-2000e when you're finished.

Factory Default (Basic) Configuration

The SSU-2000e is shipped from the factory with all required operational software. The factory default (basic) configuration often does not require further configuration. Refer to the *SSU-2000e Technical Reference* for a list of the factory default settings and the default Priority Quality Level (PQL) values.

Retrieving Factory Defaults

Use the following steps to view the factory default settings for all installed modules.

1. Log into the SSU-2000e using the procedure in [Logging In to the SSU-2000e](#), on page 102.
2. Issue the command. See Chapters 2 and 3 in the *SSU-2000e Technical Reference* for a sample response for each module.

ICS command:

SETUP xAy REPORT FACTORY and press **Enter**.

TL1 command:

`RTRV-PRMTR-SETUP: :S1A1:123: :FACTORY;`

3. Log off the SSU-2000e when you're finished.

Changing Factory Defaults

Use the following steps to change the factory default or any configuration settings in the SSU-2000e. The following example changes the Power A alarm on the Comms module from Minor to Major.

1. Log into the SSU-2000e using the procedure in [Logging In to the SSU-2000e](#), on page 102.
2. Set the alarm levels:

ICS command:

Type `alarm 1A2 03 MAJOR` and press **Enter**. See Chapter 6 in the *SSU-2000e Technical Reference* for a list of alarm numbers for each module.

TL1 command:

```
SET-PRMTR-ALARM::S1A2:123:3,MAJ;
```

3. Log off the SSU-2000e when you're finished.

Restoring Factory Defaults

Use the following procedure to reset the specified module's configuration to the factory default.

1. Log into the SSU-2000e using the procedure in [Logging In to the SSU-2000e](#), on page 102.
2. Restore the configuration to the factory default values:

ICS command:

Type `setup xAy factory` and press **Enter**.

TL1 command:

```
SET-PRMTR-SETUP::SxA[y[-z]]:123::FACTORY;
```

3. Log off the SSU-2000e when you're finished.

Customizing Other Configuration Options

The SSU-2000e allows the user to change any or all configuration settings, depending on the access level. Use the following procedures to customize the system for a particular environment.

1. Log into the SSU-2000e using the procedure in [Logging In to the SSU-2000e](#), on page 102.
2. Use the ICS or TL1 commands described in the *SSU-2000e Technical Reference* to configure the system.



Recommendation: Do not perform any command whose function you do not understand. This could result in system improper provisioning of the network.

3. Save the current configuration as the user default setting:

ICS command:

Type `setup save` and press **Enter**.

TL1 command:

```
SET-PRMTR-SETUP:::123::SAVE;
```

4. Log off the SSU-2000e when you're finished.

Retrieving the User Configuration

Use the following steps to view the saved user settings for all installed modules.

1. Log into the SSU-2000e using the procedure in [Logging In to the SSU-2000e](#), on page 102.
2. Issue the command. See Chapters 2 and 3 in the *SSU-2000e Technical Reference* for a sample response for each module.

ICS command:

SETUP 1A1 REPORT USER and press **Enter**.

TL1 command:

```
RTRV-PRMTR-SETUP:::S1A1:123::USER;
```

3. Log off the SSU-2000e when you're finished.

Backing Up and Restoring Configurations

Two new commands allow you to store a configuration file for the SSU-2000e to a TFTP (Trivial File Transfer Protocol) server. This file contains configuration data only, and not the system's firmware. The file is transferred and stored in binary format to prevent corruption of the file during transfer. The TFTP port is 69.



Note: The backup file does not include the configured IP address and serial port baud rate. This prevents the connection from possibly crashing when restoring the data.

Backing Up the Configuration

This section describes how to back up the configuration files in the SSU-2000e using ICS and TL1 commands.

Using ICS Commands

1. Connect a computer to an ICS port on the SSU-2000e and log in using an Administrator-level user name and password, as described in [Logging In to the SSU-2000e](#), on page 102.
2. Type `config backup ipaddr [filename]` and press **Enter**, where `ipaddr` is the IP address of the TFTP server and `filename` is an optional file path and name for the backup file. If you do not enter the `filename` parameter, the default file `SSUCONFIG` is stored in the root directory of the TFTP server.

An example command is:

```
config backup tftp://192.92.78.179/Symmetricom/backup/ssu2000e_July11_2006.bin
```

Using TL1 Commands

1. Connect a computer to port 2000 on the SSU-2000e and log in using an Administrator-level user name and password, as described in [Logging In to the SSU-2000e](#), on page 102.
2. Type `CPY-MEM:::123::, [tomem], todev;` where `tomem` is the file path and file name you wish to use for the configuration file, and `todev` is the IP address of the TFTP server. If you leave the `tomem` parameter empty, the default file `SSUCONFIG` is stored in the root directory of the TFTP server. The system responds with text similar to the following:

```
"\"172.16.20.246, SSUCONFIG\""  
"\"CONFIGURATION BACKUP, PLEASE WAIT\""  
"\"1A01 SIZE= 624\""  
"\"1A02 SIZE=5272\""  
"\"1A06 SIZE=3072\""  
"\"1A08 SIZE=1200\""  
"\"1A10 SIZE=1224\""  
"\"1A12 SIZE= 624\""  
"\"CONFIG IMAGE CREATED, SIZE=13788\""  
  
SSU_2000e 05-10-31 20:11:43  
M 100 COMPLD  
;
```

Restoring the Configuration

This section describes how to restore the configuration files in the SSU-2000e using ICS and TL1 commands.

Using ICS Commands

1. Connect a computer to an ICS port on the SSU-2000e and log in using an Administrator-level user name and password, as described in [Logging In to the SSU-2000e](#), on page 102.
2. Type `config restore ipaddr filename` and press **Enter**, where `ipaddr` is the IP address of the TFTP server that contains the backed-up file and `filename` is the name of the file.

An example command is:

```
config restore tftp://192.92.78.179/Symmetricon/backup/ssu2000e_July11_2006.bin
```

Using TL1 Commands

1. Connect a computer to port 2000 on the SSU-2000e and log in using an Administrator-level user name and password, as described in [Logging In to the SSU-2000e](#), on page 102.
2. Type `CPY-MEM:::123::frommem,fromdev,,;` where `frommem` is the filename of the configuration file and `fromdev` is the IP address of the TFTP server. The system responds with text similar to the following:

```
"\"172.16.20.246, SSUCONFIG\""  
  "\"CONFIGURATION RESTORE, PLEASE WAIT\""  
  "\"1A01 DATA IS SAME AS STORED\""  
  "\"1A02 SIZE=5272, PASS\""  
  "\"1A06 SIZE=3072, PASS\""  
  "\"1A08 SIZE=1224, PASS\""  
  "\"1A10 SIZE=1224, FAIL\""  
  "\"1A12 DATA IS SAME AS STORED\""  
  
SSU_2000e 05-10-31 20:12:26  
M 100 COMPLD  
;
```

Chapter 4 Commissioning the SSU-2000e

The commissioning tests for the SSU-2000e system are checklist-based operational tests performed by field engineers at the installation site after completing the installation, system turn-up, and provisioning to verify that the system is correctly installed and configured and is operating properly. After performing these tests, the system is ready to be placed in service.

In This Chapter

- [Readiness to Test Checklist](#)
- [Equipment Requirements](#)
- [Commissioning Tests](#)
- [Commissioning Test Data Sheet](#)
- [Commissioning the SDU 2000e](#)

Readiness to Test Checklist

Before performing the commissioning tests in the following section, ensure that all items in the SSU-2000e Readiness Checklist in [Table 4-1](#) have been performed. Record the results in the Checked column.

Table 4-1. SSU-2000e Readiness Checklist

Task Required for System Readiness	Checked
The SSU-2000e is installed in the rack with a minimum of 76 mm clearance between the bottom of the lowest shelf and the floor, or from other equipment in the rack.	
The SSU-2000e main shelf has minimum of 25.4 mm clearance between the top of the shelf and an adjacent shelf.	
An SSU-2000e Clock module is installed in shelf slot A1 and/or A12 as required.	
An SSU-2000e Communication module is installed in slot A2.	
At least one Input module is installed in I/O slots A3 through A5.	
<i>Optional:</i> A GPS Input module is installed in slot A3 or A5 and the correct type of Radio antenna is attached to the corresponding Radio antenna connector in the front panel. See the <i>SSU-2000e Technical Reference</i> for more information.	
At least one Output module is installed in shelf slot A4 through A10, unless the monitor only configuration is being used, or an SDU-2000e Synchronization Distribution Unit expansion shelf is installed.	
An SSU Expansion Terminator, P/N 12013049-000-0, must be installed in connector J8 if an SDU-2000e expansion chassis is <i>not</i> being used. A terminator must also be installed in connector J105 on the last expansion chassis used in the system.	
An SDU Backup Clock Terminator, P/N 12013xxx-000-0, must be installed in connector J9 if an SDU-2000e expansion chassis is <i>not</i> being used. A terminator must be installed in connector J106 on the last expansion chassis used in the system.	
External power supplies (–48/60 VDC inputs) are connected to the A and B Power input connectors on the SSU-2000e main shelf and all installed expansion shelves.	
The selected set of critical, major and minor alarms connectors on the front panel of the SSU-2000e are connected to the customer's alarm circuitry.	
At least one reference input is connected to each Input module in the SSU-2000e main shelf.	
Power-up has been performed, user configuration setup and saved, and IP addresses are assigned for the Ethernet interface.	
A System Administrator and user access levels have been assigned to the SSU-2000e, see Adding An Administrator User , on page 95.	
If the Ethernet connection is being used, the Ethernet connection on the front panel of the SSU-2000e is connected into the LAN.	

Equipment Requirements

The following equipment is required to perform the commissioning tests:

- Digital Voltmeter (DVM)
- Communications analyzer to check for correct framing, Sync Status Messaging (SSM), and line coding
- Oscilloscope with correct load terminations and cables to verify outputs



Note: If the communications analyzer has the ability to test the pulse mask, an oscilloscope is not required.

- PC or laptop with serial port and TCP/IP connectivity and terminal emulation software such as Microsoft HyperTerminal or ASCII terminal
- If testing stability and accuracy of output against another primary reference source (PRS), a phase recorder will also be required

Commissioning Tests

The following paragraphs contain the SSU-2000e commissioning test procedures. These procedures consist of the following:

- Testing the Ethernet Communications Interface
- Testing the EIA-232 Ports
- Testing the Minor alarms
- Testing the Major alarms
- Testing the Critical alarms
- Testing the Reference Input Signals
- Testing the Output signals

Testing the Ethernet Communications Interface

If an Ethernet connection to a network has been installed, use the following procedure to test the connection.

1. Telnet from the PC to the IP address assigned to the SSU-2000e system.
2. Log in by typing your assigned “username” and “password” and press **Enter**. The system should respond with the SSU-2000e prompt.
3. Type **bye** and press **Enter** to log off the system.

Testing the EIA-232 Ports

To test the EIA-232 port A:

1. Connect the PC or terminal to EIA-232 Port A as described in [Establishing a Connection With the SSU-2000e](#), on page 90.
2. Type `HELP` and press **Enter**.
3. Verify that the system responds to the command.
4. Exit the serial communication session. Move the direct connect cable to each of the remaining two serial ports and repeat steps 2 and 3.

Testing The Minor Alarms

To test the Minor alarm relay closures and software:

1. Set the Power A alarm level to MINOR:

ICS command: ALARM 1A02 MINOR

TL1 command: SET-PRMTR-ALARM::S1A2:::MINOR;

2. Remove Power A input by removing the A-bus fuse (or the fuse that supplies Power A).
3. Verify that the MINOR alarm indicator is ON.
4. Verify that a MINOR alarm is reported to the communications terminal.
5. Verify that a MINOR alarm is logged in the event log:

ICS command: EVENT ALARM

TL1 command: RTRV-EVENT::S1A2;

6. Replace the fuse to restore Power A to the unit.
7. Verify that the alarm clears, is reported and logged.

Testing the Major Alarms

To test the Major alarm relay closures and software:

1. Set the Power A alarm level to MAJOR:

ICS command: ALARM 1A02 02 MAJOR

TL1 command: SET-PRMTR-ALARM::S1A2::02:MAJOR;

2. Remove Power A input by removing A-bus fuse (or fuse that supplies Power A).
3. Verify that the MAJOR alarm indicator is ON.
4. Verify that the MAJOR alarm is reported to the communications terminal.
5. Verify that a MAJOR alarm is logged in the event log:

ICS command: EVENT ALARM

TL1 command: RTRV-EVENT::S1A2;

6. Replace the fuse to restore Power A to the unit.
7. Verify that the alarm clears, is reported and logged.

Testing the Critical Alarms

To test the Critical alarm relay closures and software:

1. Set the Power A alarm level to CRITICAL:

ICS command: ALARM 1A02 02 CRITICAL

TL1 command: SET-PRMTR-ALARM::S1A2::02:CRITICAL;

2. Remove Power A input by removing A-bus fuse (or fuse that supplies Power A).
3. Verify that the **CRITICAL** alarm indicator is ON.
4. Verify that the CRITICAL alarm is reported to the communications terminal.
5. Verify that a CRITICAL alarm is logged in the event log:

ICS command: EVENT ALARM

TL1 command: RTRV-EVENT::S1A2;

6. Replace the fuse to restore Power A to the unit.

7. Verify that the alarm clears, is reported and logged.
8. Enter the command to restore Power A to the original alarm level.

Testing the Reference Signals and Selection

To test the reference signals and selection:

1. Type `INPUT` and press **Enter** to verify each input signal is present with no alarms. Each reference input is listed by module position and port number, status, phase A and B readings, input PQL, signal alarms, and MTIE alarms.

The status should be **OK** and the Priority Quality Level (PQL) should indicate the received Sync Status Message (SSM) level or the provisioned value. The phase values will be dependent on the received signal. The signal alarms should be present (no alarms present, F indicates an alarm) and the MTIE alarms should all be **OK**.

2. Type `REF` and press **Enter** to determine the current selection of input reference signal. Disconnect this input signal and verify a Loss Of Signal (LOS) is reported for the input, and the unit selects an alternate input for the reference signal.
3. Reconnect the input signal and verify that the LOS condition is cleared and the reference input is selected according to the system configuration. This depends on the setting for Revertive Selection, Input Priorities, and Reference Selection mode.
4. Type `EVENT` and press **Enter** to verify that the alarms and events created are recorded in the event log.

Testing the Clock Section

To test the clock section:

1. Type `CLK` and press **Enter** to verify each clock is operating properly.

The system displays the clocks by module position (1A1 for Clock A and 1A12 for Clock B) and the status for each clock (SEL for the selected clock and OK for the standby clock).

2. Verify that the PLL mode for each clock is **LOCK** at this time, and that the Tau value is at the maximum time constant set for each clock, dependent on the clock type of ST2 or ST3E.

The PQL should be the level the clock is supplying to the Output modules, and depends on the reference input when in lock mode. The frequency offset is dependent on the clock type, typically less than 2×10^{-10} for ST2, less than 1×10^{-6} for ST3E, and less than 2×10^{-7} for Type I. This only indicates the uncorrected frequency offset of the oscillator which is being removed by the clock DDS circuitry.

The sigma value indicates the stability of the clock, which should be less than 1×10^{-9} .

Testing the Output Section

To test the output section:

1. Type `OUTSTAT` and press **Enter** to verify that each Output module is operating with no alarms. This command displays the Output modules by position with module status OK and the selected clock. The clock status indicates the presence or absence of the four possible clocks A, B, C (bypass), or D (expansion shelf only).
2. Verify that any outputs configured for redundant pairs are so indicated in the status report. The PQL will indicate the output SSM level for all ports and is supplied by the selected clock.
3. Verify that all output ports (which are intended to be active) indicate Y in the port status.

Testing the System Stability and Accuracy (Optional)

Perform this test only if a PRS (primary reference source) and the necessary test equipment is available. If the above tests have been passed, the system output will meet the stability and accuracy of the reference input.

1. Connect one of the system outputs and the PRS signal to the test equipment to monitor the stability and accuracy. This test should be allowed to run for 24 hours to collect sufficient data to verify the system output meets specifications.
2. Process the collected 24 hour data and verify that the frequency and stability (MTIE and TDEV) meet the specifications.

This completes the commissioning tests. The system is ready to be placed in service.

Commissioning Test Data Sheet

Complete the following test data sheet as an indicator of operational readiness of the SSU-2000e.

Table 4-2. Commissioning Test Data Sheet - SSU

Test	Pass	Fail
Ethernet communications		
EIA-232 Port A communications		
EIA-232 Port B communications		
EIA-232 Port C communications (on front of Communications module)		
MINOR Alarms		
MAJOR Alarms		
CRITICAL Alarms		
Reference Signals and Selection		
Clock Section		
Output Section		
System Stability and Accuracy (optional)		

Commissioning the SDU 2000e

The SDU-2000e expansion chassis commissioning tests are checklist-based operational tests performed by field engineers at the installation site after completing installation, system power-up, and provisioning to verify that the system is correctly installed, configured, and operating properly. After testing and verification of system functionality, the system is ready to be placed in service.

Readiness to Test Checklist

Before performing the commissioning tests in the following section, ensure that all items in the SDU-2000e Readiness Checklist, [Table 4-3](#), have been performed. Record the results in the Checked column.

Table 4-3. SDU-2000e Readiness Checklist

Task	Checked
An SDU-2000e is installed in the rack with a minimum of 76 mm clearance between the bottom of the lowest shelf and the floor, or from other equipment in the rack	
Output modules are installed in shelf slots A1 through A10, and blank filler panels are installed for all unpopulated slots	
An SDU-2000e Buffer module is installed in chassis slot A15 and A16 as required. One Buffer module is required, and a second module is optional	
An SDU Expansion Terminator (P/N 12013049-000-0) must be installed in connector J105 of the last expansion chassis used in the system	
An SDU Backup Clock Terminator (P/N 12013xxx-000-0) must be installed in connector J106 of the last expansion chassis used in the system	
The Shelf Address switch is correctly set to identify each expansion chassis location in the system. Addresses 2 through 5 correspond to shelves 1 through 4	
External power supplies (-48/60 VDC inputs) are connected to the A and B Power input connectors (J101 and J102) on each installed SDU-2000e expansion chassis	
Power-up has been performed on the SSU-2000e and SDU-2000e system	

Equipment Requirements

The following equipment is required to perform the commissioning tests:

- Digital Voltmeter (DVM)
- Communications analyzer to check for correct framing, Synchronous Status Messaging (SSM), and line coding
- Oscilloscope with correct load terminations and cables to verify outputs. If the communications analyzer has the ability to test the pulse mask, an oscilloscope is not required.
- PC or laptop with serial port and TCP/IP connectivity and terminal emulation software such as Microsoft HyperTerminal or ASCII terminal
- If testing stability and accuracy of output against another primary reference source (PRS), a phase recorder will also be required

Commissioning Tests

Perform the SDU-2000e commissioning test procedures on the following:

- Testing the Output alarms
- Testing the SSU-2000e output signals

Testing the Output Alarms

Use the following steps to test the output alarm and reporting software.

1. Remove **Power A** input power (A-BUS) in connector J101.
2. Verify that the –48/60 V POWER A indicator (LED) on the Buffer modules turns off.
3. Type **EVENTS** and press **Enter** to verify that an alarm is reported to the SSU-2000e system. An alarm should be logged into the event log at this time.
4. Replace the A-BUS connector to restore POWER A to the unit.
5. Verify that the alarm clears, and that it is reported and logged into the event log.
6. Verify that the –48/60 V POWER A LED on the Buffer modules is lit green.
7. Repeat Steps 1 through 6 for Power B input power (B-BUS) in connector J102.

Testing the Output Section

Use the following steps to test the output section.

1. Type **OUTPUT** and press **Enter** to verify each Output module is operating without alarms. The Output modules are displayed by position with module status OK and the selected clock. The clock status indicates the presence or absence of the four possible clocks A, B, C for bypass, or D for the expansion shelf only.
2. Verify that any outputs configured for redundant pairs are indicated in the status report. The Priority Quality Level (PQL) will indicate the output SSM level for all ports and is supplied by the selected clock.
3. Verify that all output ports (which are intended to be active) indicate Y in the port status.

Testing the System Stability and Accuracy (Optional)

Perform this test *only if* a primary reference source (PRS) and the necessary test equipment is available.

If the above tests have been passed, the system output will meet the stability and accuracy of the reference input.

1. Connect one of the system outputs and the PRS signal to the test equipment to monitor the stability and accuracy. This test should be allowed to run for 24 hours to collect sufficient data to verify the system output meets specifications.
2. Process the collected 24 hour data and verify that the frequency and stability (MTIE and TDEV) meet the specifications.

This completes the commissioning tests. The system is ready to be placed in service.

Commissioning Test Data Sheet

Complete the Commissioning Test Data Sheet ([Table 4-4](#)) as an indicator of operational readiness of the SDU-2000e.

Table 4-4. Commissioning Test Data Sheet - SDU

Test	Pass	Fail
EIA-232 Port A communications		
MINOR Alarms		
MAJOR Alarms		
CRITICAL Alarms		
Output Section		
System Stability and Accuracy (optional)		

Chapter 5 Maintenance and Troubleshooting

This chapter provides preventive and corrective maintenance procedures, troubleshooting procedures, and equipment re-ordering/return procedures for the SSU-2000e system.

In This Chapter

- [Responding to Alarms](#)
- [Preventive Maintenance](#)
- [Corrective Maintenance](#)
- [Troubleshooting](#)
- [Re-ordering Information](#)
- [Contacting Technical Support](#)

Responding to Alarms

The SSU-2000e monitors various system parameters and stores this information as alarms and event messages which is extremely useful in troubleshooting the system. If an alarm occurs, follow the troubleshooting procedures in [Troubleshooting](#), on page 135, to clear the alarm.

Preventive Maintenance

The SSU-2000e requires no preventive maintenance. Care should be taken to ensure the unit is not exposed to hazards such as direct sunlight, open windows, or extreme heat. See [Electromagnetic Interference \(EMI\) Considerations](#), on page 59, for other conditions that may cause damage.

Should the unit require cleaning, the exterior chassis may be wiped off using a soft cloth dampened with mild soapy water.



Caution: To avoid damage to the system, under no circumstances should the interior chassis of the SSU-2000e be allowed to come in contact with water.



Caution: To avoid damage to the system, never attempt to vacuum the interior of the SSU-2000e.



Caution: To avoid the possibility of the lithium battery exploding in the Communications module of Clock modules, **do not** replace the battery. Return the entire module to Symmetricom Global Services for battery replacement and disposal.



Caution: To avoid electrostatic discharge (ESD) and damage to the internal circuitry, never attempt to vacuum the interior of the SDU-2000e. If damaged, return the unit to the Symmetricom Global Services for corrective service.



Caution: To avoid personal injury and electrostatic discharge (ESD) damage to equipment, follow the ESD precautions as listed in this guide.

Corrective Maintenance

The SSU-2000e and SDU-2000e have a modular design; field service is limited to replacing the FRUs (field replaceable units) as identified in [Table 5-1](#) and [Table 5-2](#). This table also outlines possible component problems and corrective action. Refer to [Re-ordering Information](#), on page 141, for information on re-ordering, re-packing, or returning equipment to the factory.



Warning: To avoid serious personal injury or death, exercise caution when working near high voltage lines. In particular:

- Use extreme caution when installing the GPS antenna near, under or around high voltage lines.
 - Follow local building electrical codes for grounding the antenna system that is used with the SSU-2000e unit.
-



Caution: For continued fire protection, fuse the interface “A” power feeds at the power distribution source for (5A @ 60 VDC).

This unit must be grounded. Refer all servicing to qualified personnel.



Caution: For continued EMC compliance, replace all deformed module gaskets with the same type. Clean gaskets and mating surfaces. Secure all modules with captive screws.



Caution: To maintain EMC compliance, use only properly shielded cabling on all telecom signal wiring, including I/O, clocks, and Ethernet connections. Ensure that connections are appropriately grounded at both ends.

Table 5-1. SSU Corrective Action Table

Component	Corrective Action	Part Number
Motherboard or Main Chassis Fault	Contact Symmetricom Global Services	25413140-000-0
Defective Cable	Replace defective cable	See Chapter 9, Hardware Configuration Guide
Module Fault(s)	<ol style="list-style-type: none"> 1. Check that module(s) is seated correctly. 2. Address any fault LED lights. 3. If present, press RST button on Comm module. 4. Check both Power A and Power B inputs for a tripped breaker or blown fuse on the input power control panel. 5. Replace module. 6. If unable to correct the problem, contact Symmetricom Global Services. 	All Modules
Module Replacement		
Communications Module 2E Clock Module 3E Clock Module Type I Clock Module 1-Port DS1 Input Module 3-Port DS1 Input Module 1-Port E1 Input Module 3-Port E1 Input Module CC Input Module DS1 Output Module E1 Output Module CC Output Module 2048 kHz Output Module RS-422 Output Module E1/2048 kHz Output Module	See Handling Modules , on page 73.	23413012-000-0 23413016-000-0 23413015-000-0 23413015-001-0 23413013-001-0 23413013-002-0 23413014-001-0 23413014-002-0 23413279-000-0 23413017-000-0 23413018-000-0 23413158-000-0 23413159-000-0 23413287-000-0 23413292-000-0

Table 5-2. SDU Corrective Action Table

Component	Corrective Action	Part Number
Motherboard or Main Chassis Fault	Contact Symmetricom Global Services.	25413141-000-0
Defective Cable	Replace defective cable.	060-10003-10-2 (1 m cable; other lengths available)

Table 5-2. SDU Corrective Action Table (Continued)

Component	Corrective Action	Part Number
Module Fault(s)	<ol style="list-style-type: none"> 1. Check that module(s) is seated correctly. 2. Address any fault LED lights. 3. If present, press RST button on Comm module. 4. Check both Power A and Power B inputs for a tripped breaker or blown fuse on the input power control panel. 5. Replace module. 6. If you are unable to correct the problem, contact Symmetricom Global Services. 	All Modules
Module Replacement		
E1 Output Module		23413018-000-0
DS1 Output Module		23413017-000-0
Buffer Module		23413122-000-0
CC Output Module		23413158-000-0
2048 kHz Output Module		23413159-000-0
E1/2048 kHz Output Module		23413292-000-0
RS422 Output Module		23413287-000-0

Troubleshooting

The SSU-2000e incorporates many alarms and event messages to alert that a possible problem exists. These alarm and event message reports can be accessed via the Communications module serial ports using a dumb terminal or PC. Communication may also be established using the RJ-45 Ethernet connector (ETHERNET 10-BASE-T) on the connector interface panel of the chassis.

[Communicating by Serial Port](#), on page 91, outlines the procedures for connecting to the SSU-2000e using the Communications module serial ports. [Communicating by Ethernet](#), on page 92, outlines the procedures for connecting via the Ethernet connection. Chapter 6 of the *SSU-2000e Technical Reference* details event and alarm descriptions, default event and alarm levels, status messages and corrective action.

Establishing a Connection



Note: An SSU-2000e Administrator must be appointed prior to connecting to the system. The Administrator will assign User privileges and access codes. See [Adding An Administrator User](#), on page 95, for more details.

To perform troubleshooting on the SSU-2000e, you must establish a serial connection to a terminal, laptop or PC with terminal emulation software. This is done using port A or B (located on the back panel), or the Local port, located on the front panel of the communications module. If the SSU-2000e is connected to a LAN, an Ethernet telnet session may be established. Refer to [Communicating by Serial Port](#), on page 91, to establish a serial connection, or [Communicating by Ethernet](#), on page 92, to establish an Ethernet connection.

Troubleshooting Guide

This section describes troubleshooting procedures for the SSU-2000e. [Table 5-4](#) details event and alarm descriptions, default event and alarm levels, status messages and corrective actions.



Note: All event and alarm levels are user-configurable. Events and alarm levels listed in [Table 5-4](#) are factory defaults.

The modular design of the SSU-2000e offers a high level of stability and reliability. After installation and self-diagnostics, the majority of events and alarms can be attributed to fluctuations in signal quality, which may be self-clearing. Others may be caused by faulty hardware and software configurations. Regardless of the cause, hardware seldom needs to be replaced. If corrective action has been taken and the problem persists, call Customer Service.

When a Communications module is installed and functioning properly, it monitors the SSU-2000e and logs unit events into non-volatile memory for inspection at a later date. Events are conditions within the unit, or at the interfaces of the unit, which may indicate abnormal operation or a change in the unit's operational status. Although every alarm is considered to be an event, not every event is an alarm. For example, a login is recorded as an event but is not considered to be an alarm. In this case, no action is required by the user. Recurring events may be escalated to alarm status and may require action by the user. Conversely, alarms may be de-escalated and corrected automatically. [Corrective Maintenance](#), on page 133, explains how to interpret status messages and take corrective action if needed.

Interpreting Status Messages

The SSU-2000e provides two types of status messages: alarm and event. The following sections describe these messages.

Alarm Messages

With the exception of loss of power alarms (on main chassis and expansion unit), all alarms are module alarms. Chapter 6 of the *SSU-2000e Technical Reference* lists each module with corresponding alarm descriptions, alarm levels, status messages, and corrective action. Since a “no fault” alarm requires no action, the “Corrective Action” category applies only to fault messages requiring user intervention.

Event Messages

Chapter 6 of the *SSU-2000e Technical Reference* lists event messages categorized by module. Each section lists status messages associated with each module and an event description of each message.

Figure 5-1 shows the structure of a typical Alarm and Event report status messages.

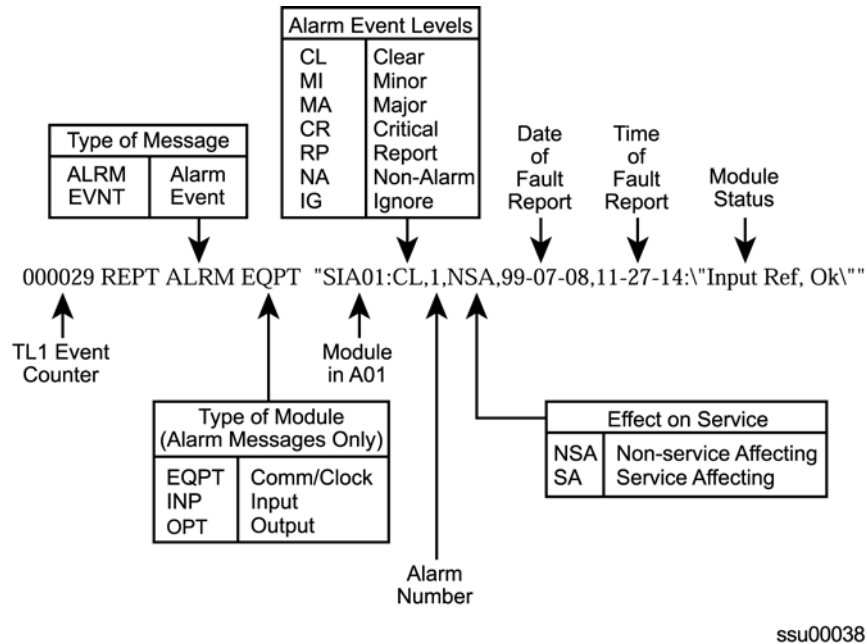

Figure 5-1. Alarm and Event Status Breakdown

Table 5-3 outlines SSU-2000e troubleshooting procedures.

Table 5-3. SSU-2000e Troubleshooting Procedures

Symptom	Probable Cause	Troubleshooting Procedure/Corrective Action
No LED lit on any module	No power to unit	Check to ensure that UPS (if applicable) is operating correctly.
	Both A and B fuses are blown	Remove both fuses and replace.
	Loss of ground	Re-attach ground wires.
	Loose power cabling to unit	Check that power cables to unit are securely fastened.
	Main shelf is faulty	Contact Symmetricom Global Services.
Unable to communicate with system	Loose cabling	Check that cabling is securely fastened.
	Bad peripheral device configuration	Check that communication device is properly configured (refer to Establishing a Connection , on page 135, for more information).
	Improperly installed or faulty Comms module	Re-seat the Comms module. Press the RST button located on the front panel of module. If problem is not rectified, call Symmetricom Global Services.
	Software emulator is configured to Com1, but cable is physically attached to Com2	Either attach cable to Com1 or re-configure software emulator to Com2.
	Software emulator is set to 9600 baud, but system baud rate is 19,200.	Change to the software emulator to 19,200 baud.
	Bad serial port(s)	Connect to another serial port. If none of the ports are functional, call Symmetricom Global Services.
Status LED on Input module is amber	Firmware compromised	Re-seat the Input module. If the problem is not rectified, call Symmetricom Global Services.

Table 5-3. SSU-2000e Troubleshooting Procedures (Continued)

Symptom	Probable Cause	Troubleshooting Procedure/Corrective Action
Fault LED on Output module is lit	Loose module	Re-seat module.
	Loss of signal to output module	Re-seat or replace input module (or clock module if necessary).
	Line fault	Remove the Tx Cable
	Improper redundancy configuration	Adjust accordingly. Main chassis: <ul style="list-style-type: none"> ■ left slot = even ■ right slot = odd Expansion chassis: <ul style="list-style-type: none"> ■ left slot = odd ■ right slot = even
Fault LED on Output module is flashing amber	Fault on distribution cabling	Verify cabling is connected properly. Replace cabling.
No LED lit on modules	Power supply failure	Check connection to power supply.
	Blown fuse	Replace module.
No alarms being reported when there is an alarmed condition	Compromised firmware	Press RST on Comms module front panel.
	Faulty Comms module	Replace Comms module.
	Alarmed module is faulty	Replace module.
Loss of power from expansion chassis	No power to unit	Check to ensure that UPS (if applicable) is operating correctly.
	Both A and B fuses on expansion chassis unit are blown	Remove fuses and replace.
	Loss of ground	Re-attach ground wires.
	Loose power cabling to expansion unit	Check that power cables to unit are securely fastened.
	Expansion chassis is faulty	Call Symmetricom Global Services.
Loss of signal from expansion chassis	D clock not connected while loose SDU cable to the expansion chassis	Check SDU cable and connect D clock.
Any amber source LED on the Output module	Loss of clock signal	Ensure clock modules are inserted properly.
	Clock modules are in warm-up mode	No action necessary.

Table 5-3. SSU-2000e Troubleshooting Procedures (Continued)

Symptom	Probable Cause	Troubleshooting Procedure/Corrective Action
Any amber LED on Input module	No signal to the input panel	Ensure signals are properly routed to the input panel.
	No input signal on cable connected to input panel	Replace <i>no-signal</i> cable with signaled cable.
	I/O input adapter panel is not connected to the input module	Connect the I/O input adapter panel to the input module.
No output signal on the output panel	Port is not turned on	Use the appropriate command to turn the port on.
	The I/O output adapter panel is not connected to the output module	Connect the I/O output adapter panel to the Output module.

Troubleshooting the SDU-2000e

The buffer module in the SDU-2000e collects status information from the Output modules and relays status messages to the SSU-2000e. The status messages alert the SSU-2000e when a possible problem exists; they can be accessed through the SSU-2000e using a terminal or PC using a terminal emulation software. Refer to [Establishing a Connection With the SSU-2000e](#), on page 90, for more information on connecting to an SSU-2000e for troubleshooting. [Table 5-4](#) outlines troubleshooting procedures for the SDU-2000e.



Note: If fault isolation and corrective action have been performed and the problem persists, contact Symmetricom Global Services.

Table 5-4. SDU-2000e Troubleshooting Procedures

Symptom	Probable Cause	Troubleshooting Procedure/Corrective Action
Output module Fault indicator is on	Loose module	Re-seat module.
Output module Fault indicator is flashing Amber	Fault on distribution cabling	Verify that cabling is connected properly. Replace cabling as needed.
Output module Source indicator amber	Loss of clock signal	Ensure cabling to main chassis is secure and correctly installed.
	Clock modules in main chassis are in Warm-up mode	No action necessary.

Table 5-4. SDU-2000e Troubleshooting Procedures (Continued)

Symptom	Probable Cause	Troubleshooting Procedure/Corrective Action
Indicators on any module are not illuminated	No power to unit	Verify that there is power to BUS-A and BUS-B, and that the power inputs are providing the required –48/60 VDC to the unit.
	Loss of ground	Re-attach ground wires.
	Loose power cabling to unit	Check that power cables to unit are securely fastened.
	Expansion shelf is faulty	Contact Symmetricom Global Services.
Loss of signal to/from expansion chassis	Loose SDU cable to the expansion chassis	Check SDU cable.
	Both clocks not connected	Connect one or both clocks.

Re-ordering Information

To re-order any module or accessory, contact the Sales Department at Symmetricom. Provide the module or accessory name and its item number along with a purchase order number. A current list of SSU-2000e system components modules/accessories and their part numbers is provided in [Chapter 9, Hardware Configuration Guide](#).

Equipment Return Procedure

You should return the equipment to Symmetricom only after you have exhausted the troubleshooting procedures described earlier in this chapter, or if Symmetricom Global Services has advised you to return the unit.



Note: Please retain the original packaging of the unit for re-shipping the product as needed. If the original packaging has been discarded, contact Symmetricom Global Services (SGS) for assistance.

Repacking

Use standard packing procedures to protect the SSU-2000e or any of the SSU-2000e modules during shipment. Connectors should be protected with connector covers or the instrument should be wrapped in plastic before packaging. Custom foam packing material is preferred because it conforms to the shape of the instrument. Take special care to protect the front and rear panels.

To return equipment to Symmetricom for repair:

1. Call Symmetricom Global Services (SGS) at 888-367-7966 (toll-free in USA only), 408-428-7907, or +44 (0) 1189 699 799 in Europe, Middle East, or Africa to obtain a return material authorization number (RMA) before returning the product for service. Retain this RMA number for future reference.
2. Provide a description of the problem, product item number, serial number, and warranty expiration date.
3. Provide the return shipping information (customer field contact, address, telephone number, and so forth.)
4. Ship the product to Symmetricom, transportation prepaid and insured, with the Return Material Authorization (RMA) number and item numbers or part numbers clearly marked on the outside of the container to the address given to you by SGS.

Repaired equipment is returned to you with shipping costs prepaid by Symmetricom.

Contacting Technical Support

If you encounter any difficulty installing, operating, or maintaining the product, contact Symmetricom Global Services at:

Symmetricom, Inc.
2300 Orchard Parkway
San Jose, CA 95131-1017

U.S.A. Call Center:
888-367-7966 (from inside U.S.A. only – toll-free)
408-428-7907
Fax: 408-428-7998
E-mail: support@symmetricom.com

Europe, Middle East, and Africa (EMEA) Call Center:
+49 700 3288 6435
Fax: +49 810 4662 433
E-mail: emeasupport@symmetricom.com

Internet: <http://www.symmetricom.com>

Chapter 6 Clock and Communications Module Reference Data

This chapter contains reference information for the Clock and Communications modules available for use in the SSU-2000e system.

In This Chapter

- [Stratum 2E Clock Module](#)
- [Stratum 3E Clock Module](#)
- [Type I Clock Module](#)
- [Communications Module](#)

Stratum 2E Clock Module

This section provides user reference information for the Stratum 2E Clock module (part number 23413016-000-0) used in the SSU-2000e.

Functional Overview

The Stratum 2E Clock module uses a Rubidium oscillator and meets or exceeds the performance requirements for ITU and ETSI Type I Transit and Type II Local Node clocks and ANSI and Telcordia Technologies (Bellcore) Stratum 2 clocks.

The Clock module reads measurement data from the Input modules, provides frequency control of the oscillators through DDS circuitry, and generates a reference signal used by the input and Output modules.

A typical SSU-2000e system contains dual redundant Clock modules. Each Clock module maintains phase synchronization with the redundant Clock module. Its hardware and software also provides for temperature compensation, an initial offset adjustment, and frequency adjustment resolution of $1 \times 10E^{-13}$ or better.

With redundant Clock modules, one is selected as the master and the other as backup, with automatic switching on module removal or failure.

The master Clock module controls the operation of the input and Output modules and downloads module configuration information to all modules (except for the Communications module), requests measurement data and status from the Input modules, and sets the Output modules to use currently selected clock signals. The Clock modules maintain an internal time-of-day clock that is used to time stamp events to within 0.1 second of detection of the event.

This module provides an 8 kHz signal used by the Input modules and a 4 kHz signal used by the Output modules. Each Clock module provides one set of signals for use by the modules in the main chassis, and a separate set for the expansion shelves.

Functional Block Diagram

A simplified block diagram of the Stratum 2E Clock module is shown in [Figure 6-1](#).

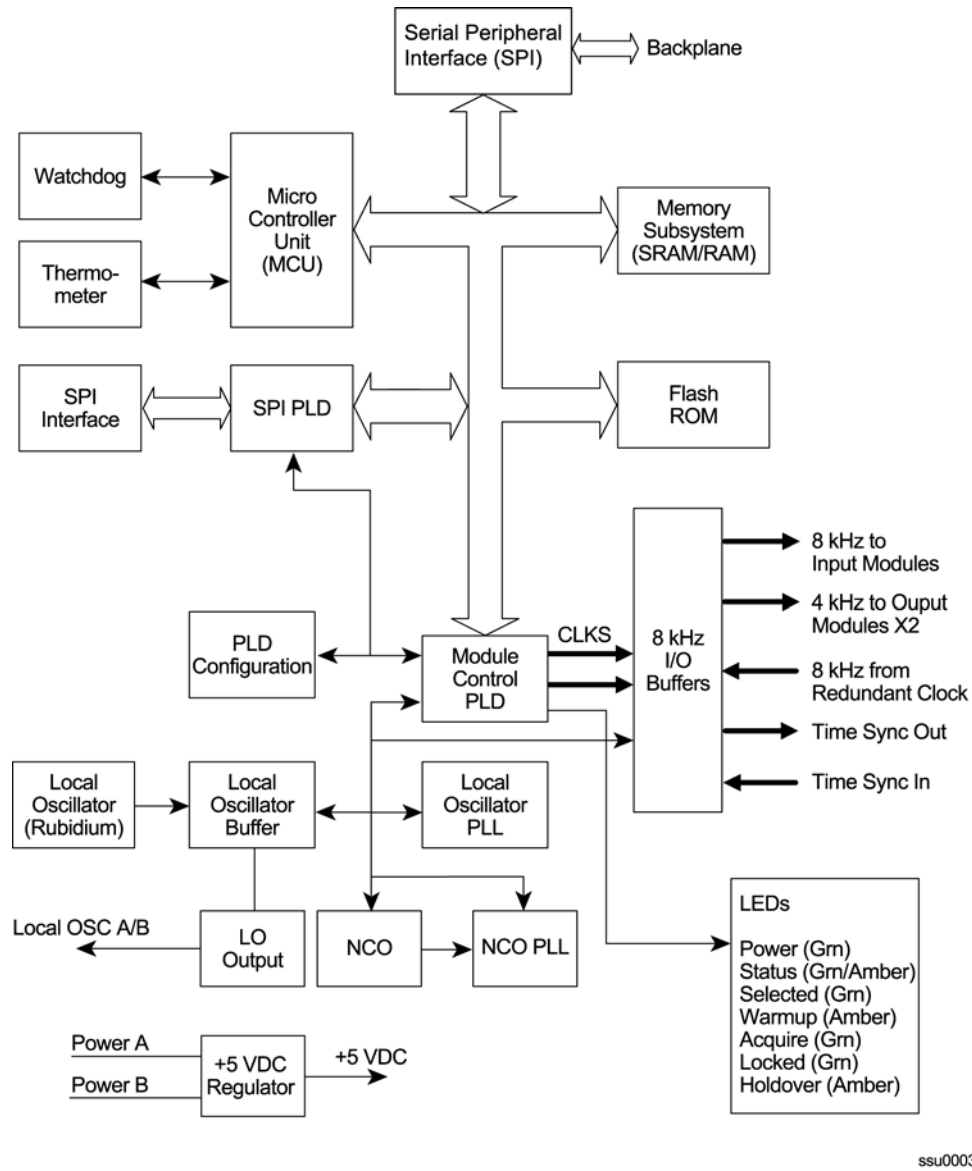

Figure 6-1. Block Diagram of the Stratum 2E Clock Module

Status LED Indicators

The Stratum 2E Clock module status LED indicators are illustrated in [Figure 6-2](#) and are described in [Table 6-1](#).

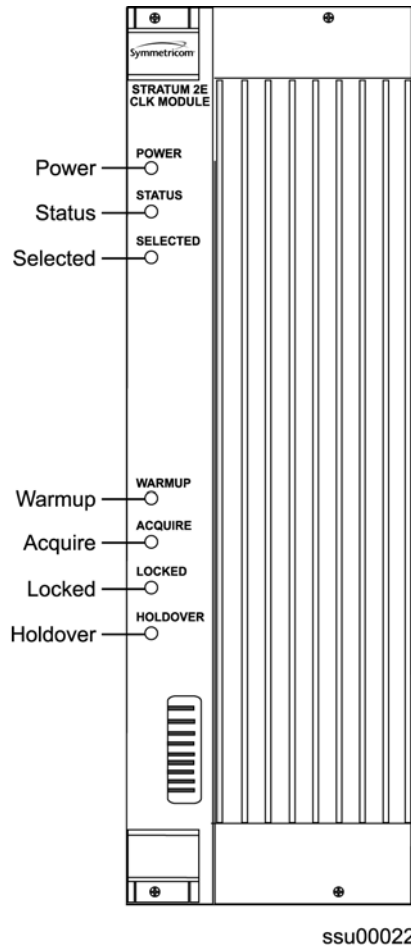

Figure 6-2. Front Panel of the Stratum 2E Clock Module

Table 6-1. Stratum 2E Clock Module Status LED Indicators

Indicator	Color	Description
Power	Green	On = The clock module is receiving power Off = No Power Present
Status	Green/Amber	On (Green) = No faults detected On (Amber) Blinking = Clock module is downloading firmware On (Amber) = Unknown Clock module status or fault detected
Selected	Green	On = Module selected for providing outputs Off = Module not selected

Table 6-1. Stratum 2E Clock Module Status LED Indicators (Continued)

Indicator	Color	Description
Warmup	Amber	On = Clock module is in warm-up mode Off = Clock module has completed warmup
Acquire	Green	On = Clock module is acquiring a lock on a signal Off = Not acquiring a lock on a signal
Locked	Green	On = Clock module is locked on a signal Off = Clock module is not locked on a signal
Holdover	Amber	On = Clock module is in holdover mode of operation, downloading firmware from the communication module (cannot be selected during this period) Off = Clock module is not in holdover

Functional Specifications

Table 6-2 lists the specifications for the Stratum 2E Clock module.

Table 6-2. Stratum 2E Clock Module Specifications

Performance Characteristic	Specification
Free Running Accuracy	Within $\pm 5 \times 10E^{-10}$ the first year Within $\pm 5 \times 10E^{-9}$ after 10 years
Holdover Stability (Rubidium LO) 0 to 24 hrs, @ +10 to +50°C 0 to 24 hrs, @ 0 to +50°C 30 days @ +10 to +40°C 30 days @ 0 to +50°C	$\pm 9 \times 10E^{-11}$ $\pm 1 \times 10E^{-10}$ $\pm 1.5 \times 10E^{-10}$ $\pm 1.7 \times 10E^{-10}$
Numeric Controlled Oscillator (NCO) PLL lock range	$\pm 2 \times 10E^{-4}$
Tuning Resolution (Locked Mode)	$< 1 \times 10E^{-13}$
Warm-up Time (Warm-up Mode)	20 minutes
Wander Output (Holdover)	Includes effects of all SSU-2000e modules: Compliant with clock levels per ITU-T G.812, T1.101-1999, and Telcordia Technologies GR-378-CORE and GR-1244-CORE. Meets SONET requirements per T1.105. Meets or exceeds performance requirements for ITU-T G.812 Type II and ETSI Transit Node clocks and T1.101 and Telcordia Technologies (Bellcore) Stratum 2 clocks.
Jitter (Locked or Holdover)	< 4 ns p-p (measured at the CLKA/BIN 8 kHz output)

Configuration Data

Table 6-3 contains a listing of software configuration options and factory defaults for the Stratum 2E Clock module.

Table 6-3. Stratum 2E Clock Module Options/Defaults

Setting	Default	Range
Warmup Time	1200 seconds	900 to 3600 seconds
Min Tau Limit	300 seconds	Constant
Max Tau Limit	10000 seconds	Constant
Min Tau	300 seconds	In the range specified in Min/Max Tau limits
Max Tau	9000 seconds	In the range specified in Min/Max Tau limits
Clk Switch AR	On	On/Off
Input Switch	AutoReturn (AR)	AR (2)/AS On (1)/AS Off (0)
Input Selection Mode	Priority	Priority (0)/PQL (1)
Local Oscillator (LO)	On	On/Off
Frequency Offset	57 ppb	Constant
Elevation Time	86 400 seconds	60 to 500 000 seconds

Stratum 3E Clock Module

This section provides user reference information for the Stratum 3E Clock module (part number 23413015-000-0 used in the SSU-2000e. This module provides a lower cost backup clock solution for the system.

Functional Overview

The Stratum 3E Clock module meets or exceeds the performance requirements for ITU and ETSI Type III Local Node clocks and ANSI and Telcordia Technologies (Bellcore) Stratum 3E clocks.

The Stratum 3E Clock module receives measurement data from the Input modules, provides frequency control of the outputs through DDS circuitry, and generates a reference signal for use by the Input and Output modules. The Stratum 3E Clock module communicates with the Communications module and the Stratum 2E Clock module to maintain phase synchronization with the redundant Clock module. The Stratum 3E Clock module's hardware and software provides for temperature compensation, aging compensation for the Quartz oscillator, an initial offset adjustment, and frequency adjustment resolution of $1 \times 10E^{-13}$ or better.

When serving as the master clock, the Stratum 3E Clock module controls the operation of the Input and Output modules and downloads module configuration information to all modules, requests measurement data and status from the Input modules, and sets the Output modules to use currently selected Clock signals. The Stratum 3E Clock module also contains a battery powered clock that maintains the clock for timestamping events. The Clock module software reads the clock on startup and sets the clock when the system time is changed. The timestamp is referenced as the number of seconds since 00:00:00 January 1, 1980.

Functional Block Diagram

A simplified block diagram of the Stratum 3E Clock module is provided in [Figure 6-3](#).

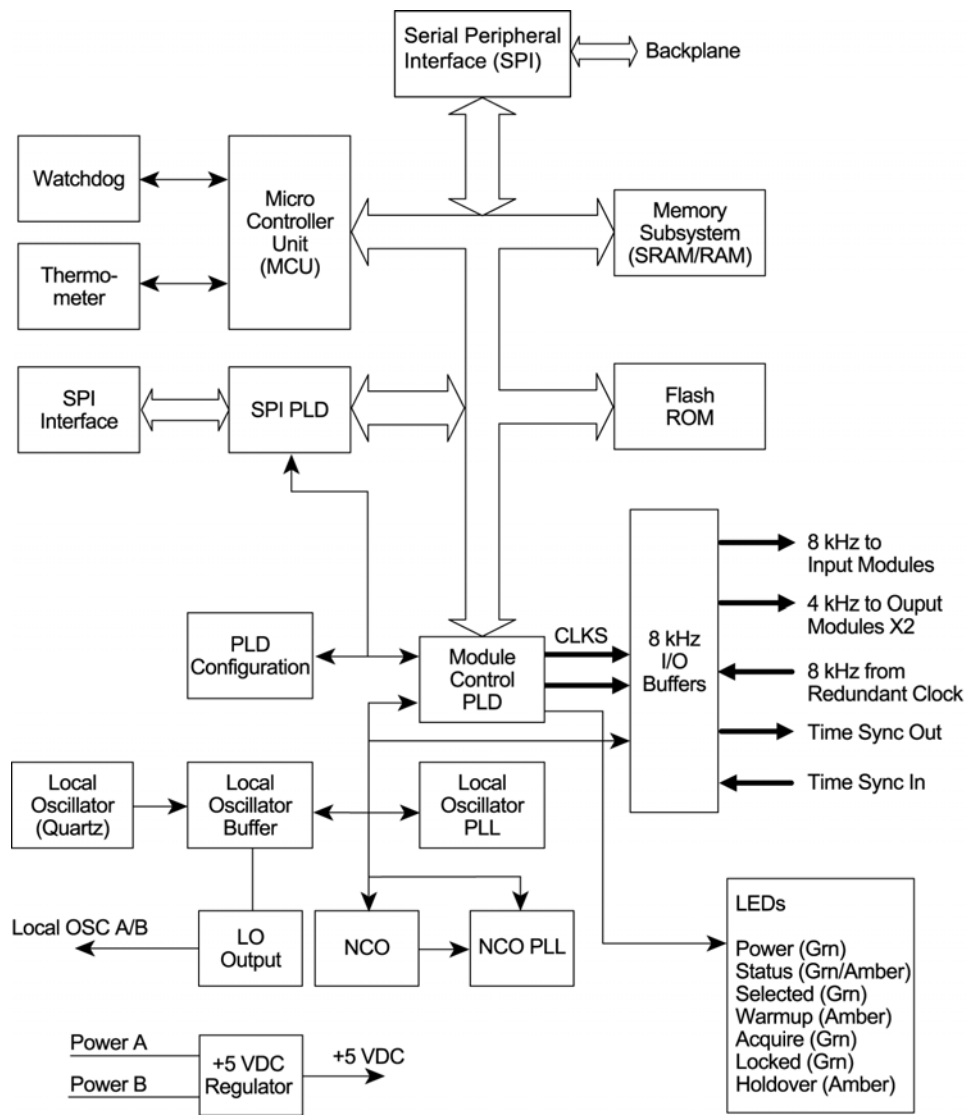

ssu00040

Figure 6-3. Block Diagram of the Stratum 3E Clock Module

Status LED Indicators

The Stratum 3E Clock module status LED indicators are illustrated in [Figure 6-4](#) and are listed in [Table 6-4](#).

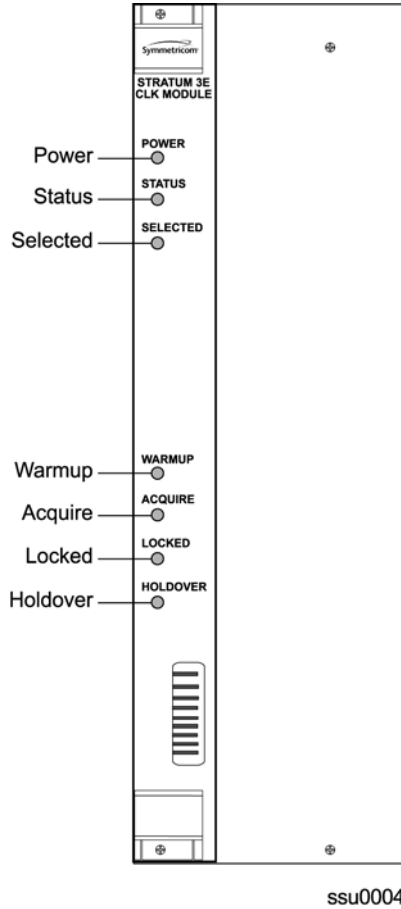

Figure 6-4. Front Panel of the Stratum 3E Clock Module

Table 6-4. Stratum 3E Clock Module Status LED Indicators

Indicator	Color	Description
Power	Green	On = The clock module is receiving power Off = No Power Present
Status	Green/Amber	On (Green) = No faults detected On (Amber) Blinking = Clock module is downloading firmware On (Amber) = Unknown Clock module status or fault detected

Table 6-4. Stratum 3E Clock Module Status LED Indicators (Continued)

Indicator	Color	Description
Selected	Green	On = Module selected for providing outputs Off = Module not selected
Warmup	Amber	On = Clock module is in warm-up mode Off = Clock module has completed warmup
Acquire	Green	On = Clock module is acquiring a lock on a signal Off = Not acquiring a lock on a signal
Locked	Green	On = Clock module is locked on a signal Off = Clock module is not locked on a signal
Holdover	Amber	On = Clock module is in holdover mode of operation, downloading firmware from the communication module (cannot be selected during this period) Off = Clock module is not in holdover

Performance Specifications

Specifications for the Stratum 3E Clock module are provided in [Table 6-5](#).

Table 6-5. Stratum 3E Clock Module Performance Specifications

Performance Characteristic	Specification
Free Running Accuracy	Within $\pm 2.5 \times 10^{-7}$, the first year (vendor spec) Within $\pm 3.7 \times 10^{-6}$ after 20 years (vendor spec)
Holdover Stability 0 to 24 hrs, @ +10 to +50°C 0 to 24 hrs, @ 0 to +50°C	$\pm 5 \times 10^{-9}$ $\pm 1 \times 10^{-8}$
Numeric Controlled Oscillator (NCO) PLL lock range	$\pm 2 \times 10^{-4}$
Tuning Resolution (Locked Mode)	$< 1 \times 10^{-13}$
Warm-up Time (Warm-up Mode)	20 minutes
Wander Output (Holdover)	Includes effects of all SSU-2000e modules: Exceeds requirements of ITU G.811, ANSI T1.101-1994, T1.105.09, T1X1.3 (proposed new limits for wander generation), and G.823
Jitter (Locked or Holdover)	< 4 ns p-p (measured at the CLKA/BIN 8 kHz output)

Configuration Data

The Stratum 3E Clock module is software configurable through one of the serial or Ethernet ports. The default values and the ranges for the configurable parameters are listed in [Table 6-6](#).

Table 6-6. Stratum 3E Clock Default Values and Ranges

Setting	Default	Range
Warmup Time	1200 seconds	900-3600 seconds
Min Tau Limit	300 seconds	Constant
Max Tau Limit	500 seconds	Constant
Min Tau	300 seconds	In the range specified in Min/Max Tau limits
Max Tau	450 seconds	In the range specified in Min/Max Tau limits
Clk Switch AR	On	On/Off
Input Switch	AutoReturn (AR)	AR (2)/AS On (1)/ AS Off (0)
Input Selection Mode	Priority	Priority (0)/PQL (1)
Local Oscillator (LO)	On	On/Off
Frequency Offset	57 ppb	Constant
Elevation Time	86 400 seconds	60 to 500 000 seconds

Type I Clock Module

This section provides operating instructions and software provisioning procedures for the Type I Clock module (part number 23413015-001-0), designed for use in the SSU-2000e Synchronization Supply Unit.

Functional Overview

The Type I Clock module uses a quartz oscillator which meets or exceeds the performance requirements for ITU and ETSI Type I Slave clocks. The Clock module reads measurement data from the Input modules, provides frequency control of the oscillator through DDS circuitry, and generates reference signals used by the Input and Output modules.

A typical SSU-2000e shelf contains dual redundant Clock modules. Each Clock module maintains phase synchronization with the redundant Clock module. Its hardware and software also provides an initial offset adjustment and frequency adjustment resolution of 1×10^{-13} or better.

With redundant Clock modules, one is selected as the master and the other as backup, with automatic switching on module removal or failure.

The master Clock module controls the operation of the Input and Output modules and downloads module configuration information to all modules (except for the Communications module), requests measurement data and status from the Input modules, and sets the Output modules to use currently selected clock signals, and provides the system Priority Quality Level (PQL) to all Output modules configured to generate Synchronization Status Messages (SSMs). The Clock modules maintain an internal time-of-day clock that is used to time stamp events to within 0.1 second of detection of the event.

This module provides an 8 kHz signal used by the Input modules and a 4 kHz signal used by the Output modules. Each Clock module provides one set of signals for use by the modules in the main chassis, and a separate set for the expansion shelves.

Functional Block Diagram

A simplified block diagram of the Type I Clock module is shown in [Figure 6-5](#).

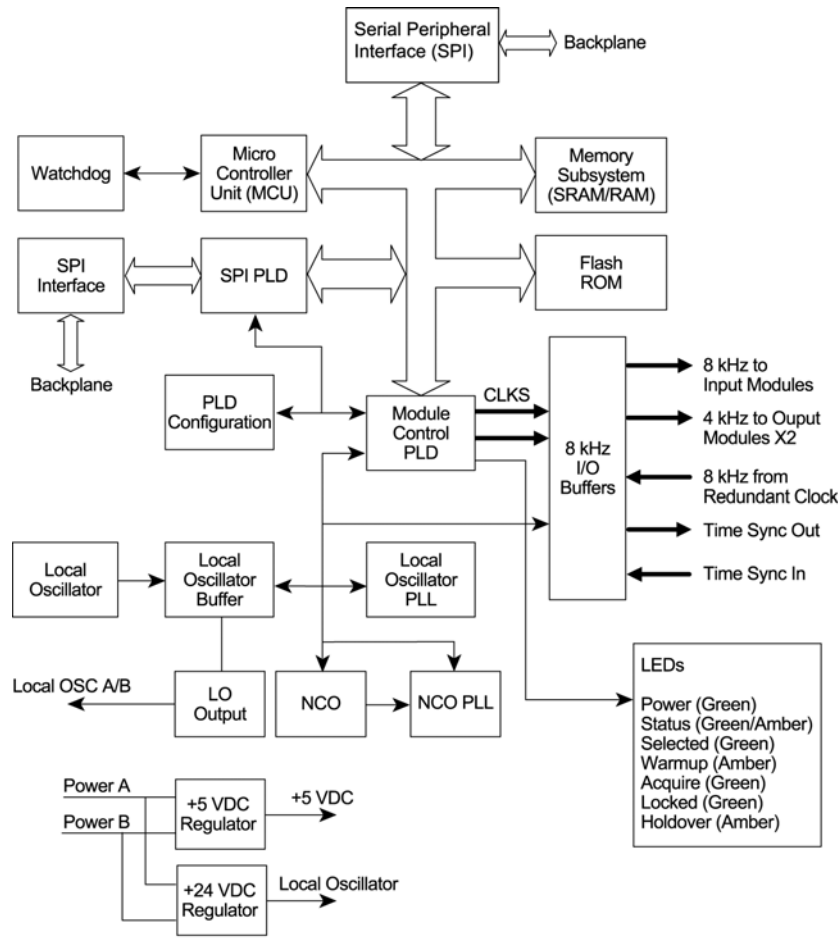

ssu00064

Figure 6-5. Block Diagram of the Type I Clock Module

Status LED Indicators

The status LED indicators on the Type I Clock module are illustrated in [Figure 6-6](#) and are described in [Table 6-7](#).

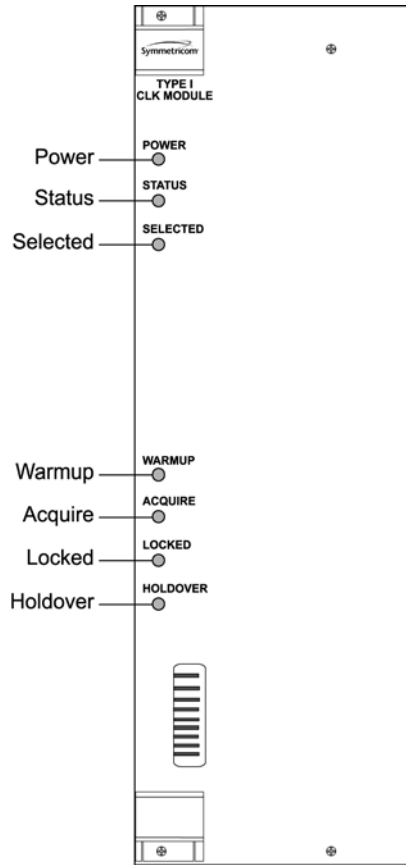

ssu00065

Figure 6-6. Front Panel of the Type I Clock Module

Table 6-7. Type I Clock Module Status LED Indicators

Indicator	Color	Description
Power	Green	On = The Clock module is receiving power Off = No power present
Status	Green/Amber	On (Green) = No faults detected On Amber blinking = Clock module is downloading firmware On (Amber) = Unknown Clock module status or fault detected
Selected	Green	On = Module selected for providing clock signals for output generation. Off = Module not selected
Warmup	Amber	On = Clock module is in warm-up mode Off = Clock module has completed warmup

Table 6-7. Type I Clock Module Status LED Indicators (Continued)

Indicator	Color	Description
Acquire	Green	On = Clock module is acquiring a lock on a signal Off = Not acquiring a lock on a signal
Locked	Green	On = Clock module is locked on a signal Off = Clock module is not locked on a signal
Holdover	Amber	On = Clock module is in Holdover mode of operation Off = Clock module is not in Holdover mode

Functional Specifications

Table 6-8 lists the specifications for the Type I Clock module.

Table 6-8. Type I Clock Module Specifications

Performance Characteristic	Specification
Holdover Stability 0 to 24 hrs @ -5 to +45°C	$\pm 2 \times 10^{-9}$ (after 30 days operation)
Numeric Controlled Oscillator (NCO) PLL lock range	$\pm 5 \times 10^{-4}$
Tuning Resolution (Locked Mode)	$< 1 \times 10^{-13}$
Warm-up Time (Warm-up Mode)	20 minutes
Wander Output (Holdover)	Includes effects of all SSU-2000e modules: Compliant with clock levels per ITU-T G.812, Type I and ETSI EN300 462-4
Jitter (Locked or Holdover)	< 4 ns p-p (measured at the CLKA/BIN 8 kHz output)

Configuration Data

Prior to shipping, all required operational software is factory-loaded. The SSU-2000e ships with a factory default (basic) configuration set and often does not require further configuration. Refer to the *SSU-2000e Technical Reference* for a list of the factory default settings and the default Priority Quality Level (PQL) values.

Table 6-9 contains a listing of software configuration options and factory defaults for the Type I Clock module.

Table 6-9. Type I Clock Module Options/Defaults

Setting	Default	Range
Warmup Time	1200 seconds	900 – 3600 seconds
Min Tau	330 seconds	150 – 1200 seconds
Max Tau	450 seconds	150 – 1200 seconds
Clk Switch AR	On	On/Off
Input Switch	AutoReturn (AR)	AR (2)/AS On (1)/AS Off (0)
Input Selection Mode	Priority	Priority (0)/Pql (1)
Local Oscillator (LO)	OFF	On/Off
Alarm Elevation Time	86 400 seconds	60 to 500 000 seconds; 0 disables alarm

Communications Module

This section provides reference information on the Communications module (part number 23413012-000-0) that functions as a master controller for the SSU-2000e.

Functional Overview

The Communications module installs in slot A2 and provides an interface between the user and the SSU-2000e system. This interface allows users to display and control much of the activity in the SSU-2000e system and the optional SDU-2000e expansion system. The Communications module supports three serial ports (including one local craft port) and one Ethernet port, and allows communication over each of them independently in one of several possible modes (ASCII mode, TL1 mode, and packet mode).

The software in the Communications module allows for reprogramming of its flash ROM and for reconfiguration of all programmable logic devices, while installed at the user's location. The Communications module also allows for this same capability for the input and clock modules. The software on all other modules installed in the SSU-2000e system can be updated by downloading it through the Communications module.

When the Communications module is installed, it performs an initial software verification test to verify operation. If the module is installed in the SSU-2000e with power already applied and with other modules installed, the Communications module reads the configuration of the modules in the SSU-2000e and the modules in all installed SDU-2000e expansion shelves. This information is saved in nonvolatile memory on the Communications module. If power is applied to the SSU-2000e after the Communications module is installed, it initializes before any other module and provides configuration information to the individual modules.

The master controller function for the SSU-2000e can reside in the Communications module or in either of the Clock modules. The priority of the selection of the module that will provide the master controller function rests with the Communications module, Clock A, and Clock B, in that order. In the event of removal of the module designated as the master controller, that function automatically and seamlessly switches to the next module in priority order.

All man/machine communications are controlled by the Communications module. This module then communicates with the other modules in the SSU-2000e to read configuration data, set operational parameters, and determine what type of modules are installed. When a module is replaced, the controller loads the correct operational parameters into the replacement module.

Functional Block Diagram

A simplified block diagram of the Communications module is shown in [Figure 6-7](#).

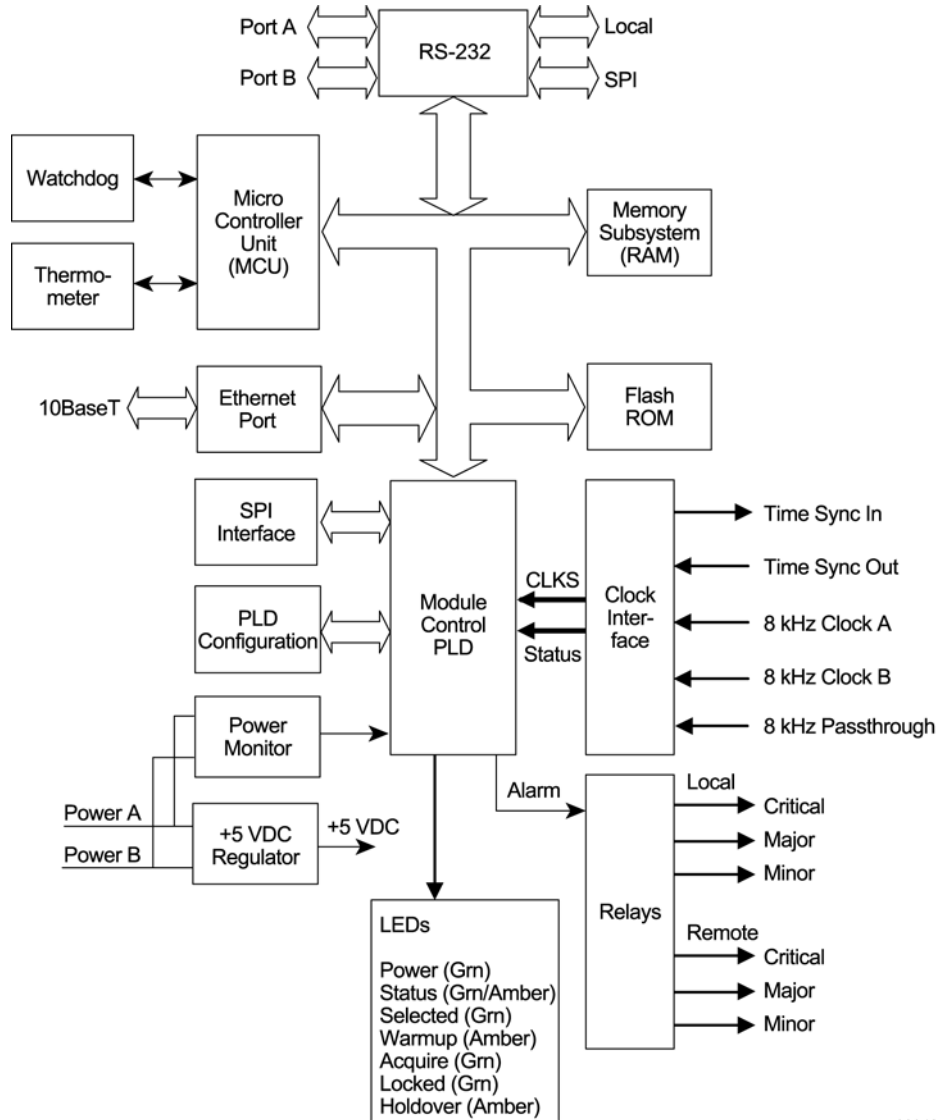

ssu00042

Figure 6-7. Block Diagram of the Communications Module

Status LED Indicators

The Communications module contains a group of eight status LED indicators that convey visual status to the user, as shown in [Figure 6-8](#) and described in [Table 6-10](#).

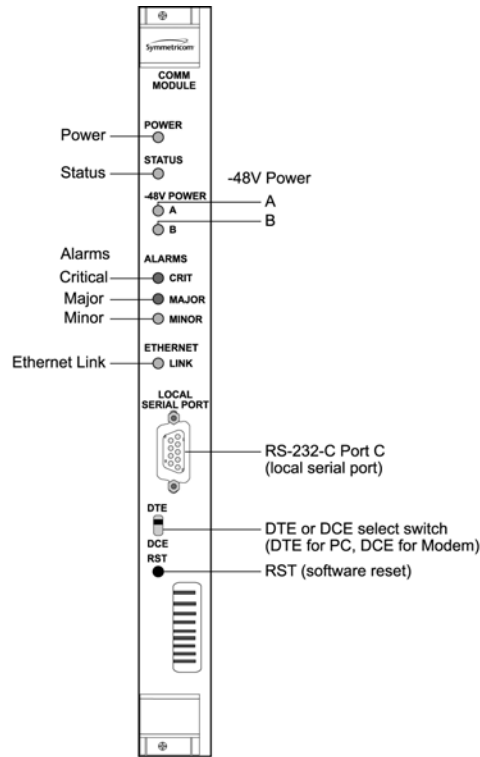

ssu00032

Figure 6-8. Front Panel of the Communications Module

Table 6-10. Communications Module Status LED Indicators

Indicator	Color	Description
Power	Green	On = The module is receiving power Off = No Power Present
Status	Green/Amber	On (Green) = No faults detected On (Amber) Blinking = Module is downloading firmware On (Amber) = Module fault detected
-48VDC Power A and B	Green	On = Power connected Off = Power not connected
Critical Alarm	Red	On = System alarm is set to Critical Off = No critical system alarm
Major Alarm	Amber	On = Major system alarm Off = No major system alarm
Minor Alarm	Amber	On = Minor system alarm Off = No minor system alarm
Ethernet Link	Green	On = Physical Ethernet connection is made Off = No physical Ethernet connection

Alarm Logic

Events are an indication that something has occurred within the unit. Alarms are a subset of events. All alarms are events, but not all events are alarms. All events log the following information:

- Timestamp
- Event type
- Event/alarm level
- Condition that caused the event

Communications Module Event Log

The Communications module maintains an event history of the last 500 events in non-volatile RAM that can be retrieved by the user. In the interactive mode, the Communications module always returns the events with the last generated event output last.

Using one of the available communication ports, a user can request the following:

- List of events by a given type of REPORT or ALARM
- List of events based upon a start and stop time
- Clear the event log

Interactive mode ports can request:

- Latest event logged
- A number of last events be displayed
- All information currently logged in the history buffer

Alarm Levels

The Communications module alarm logic incorporates three alarm levels:

- **CRITICAL Alarms** – This class of alarms that require immediate user intervention. When a critical alarm condition is detected, the CRITICAL ALARM relay at the back of the SSU-2000e is activated and the CRITICAL ALARM LED on the front of the Communications module lights red.
- **MAJOR Alarms** – A class of alarms that may require immediate user intervention. When a major alarm condition is detected, the major alarm relay at the back of the SSU-2000e is activated and the MAJOR ALARM LED on the front of the Communications module lights red.
- **MINOR Alarms** – A class of alarms that indicate the unit performance is degrading. The minor relay is activated and the MINOR ALARM indicator lights.

Alarms are elevated from MINOR to MAJOR to CRITICAL on a per module basis with a user-set time, from 60 to 500 000 seconds; the default is 86 400 seconds, or one day. The elevation time is stored in each module.

You can select delay periods for software alarms from 0 to 86400 seconds. Changing the delay period generates an event. The setting is stored in each module.



Note: If the original value is set to IMMED (–1), it means this error delay is not allowed to change and will happen immediately.

Table 6-11 lists the Communications module alarms.

Table 6-11. Communications Module Alarms

ID	Description	Alarm Level	Error Delay Default	Error Delay Settable
0x0	Backplane Communication Errors	MINOR	5 sec	Yes
0x1	Mastership Problems	MINOR	5 sec	Yes
0x2	Loss of Power A	MINOR	Immediate	No
0x3	Loss of Power B	MINOR	Immediate	No
0x4	SPI Watchdog Timeout	MAJOR	Immediate	No
0x5	Shelf 2 Communications	CRITICAL	0 sec	Yes
0x6	Shelf 3 Communications	CRITICAL	0 sec	Yes
0x7	Shelf 4 Communications	CRITICAL	0 sec	Yes
0x8	Shelf 5 Communications	CRITICAL	0 sec	Yes
0x9	Module Removed	MINOR	5 sec	Yes

Configuration Data

Table 6-12 lists the factory default settings and ranges for the communication module software configuration options.

Table 6-12. Communications Module Configuration Data

Configuration Setting	Factory Default
Unit Name	SSU-2000e
User List configurations	Maximum of 25 users including four built-in users
Module Information configurations	<p>Current Configuration – the configuration that is currently in use</p> <p>User Default Configuration – configuration the user specifies as the default if the current configuration is invalid or not present</p> <p>Factory Configuration – the factory default configuration</p>

Table 6-12. Communications Module Configuration Data (Continued)

Configuration Setting	Factory Default
EIA-232-C Port	All three comm ports are set to 9600 baud, Interactive Mode, CRLF, and Echo on.
Comm Port Timeout	Five minutes for all (Interactive Mode). Note: the unit should have one user added. i.e. Not in the INITUSERTABLE state. If it is in the INITUSERTABLE state, no timeout is applied. No Timeout is assigned for the TL1 Mode
Ethernet IP Address	IP Address 0.0.0.0 Gateway Address 0.0.0.0 Network Mask 255.255.255.0

EIA-232 Ports

The Communications module implements four EIA-232 ports that provide for local and remote communications with the SSU-2000e system.

A user interface (software resident in the Communications module) provides various levels of password-protected access for configuration and detailed performance monitoring and diagnostics. Use either the interactive command set or the TL1 user interface (see the *SSU-2000e Technical Reference*) for configuring and detailed performance monitoring.

The ports include:

- **Port A and Port B** – Tied to external connectors on the back of the SSU-2000e main chassis.
- **One local port** – Tied to the connector on the front of the Communications module.
- **Backplane communications port** – Used to communicate with other modules in the system.

Ethernet Port

The Communications module implements one Ethernet port (ETHERNET 10-BASE-T) that is routed to an RJ-45 connector on the back of the main chassis. For more information on Ethernet settings, see [Communicating by Ethernet](#), on page 92.

Resetting the Module

The recessed RST button on the front panel of the Communications module resets the software. Use this button *only* if you cannot acquire access to the SSU-2000 using the serial or Ethernet ports. A contact closure on the Remote Reset connector on the rear panel also performs the Reset function (see [Remote Reset](#), on page 72).

Chapter 7 Input Module Reference Data

This chapter contains reference information for the Input modules available for use in the SSU-2000e.

In This Chapter

- [1-Port and 3-Port E1 Input Modules](#)
- [1-Port and 3-Port DS1 Input Modules](#)
- [GPS Input Module](#)
- [Composite Clock Input Module](#)

1-Port and 3-Port E1 Input Modules

This section describes the 1-Port (part number 23413014-001-0) and 3-Port (part number 23413014-002-0) E1 Input modules that may be installed in an SSU-2000e system.

Functional Overview

The 1-Port and 3-port E1 Input modules receive signals and perform phase measurement comparisons with the Clock modules that are installed in the SSU-2000e. The Clock modules use this information to phase and frequency lock to the incoming signal. The data may also be used for monitoring the frequency of incoming signals.

The input ports accept one (1-Port Input module), or three (3-Port Input modules) of the following signals: sine or square wave, with a frequency of 1, 1.544, 2.048, 5 or 10 MHz, or framed communication type E1. If the input signal is a communications type, the module monitors for Alarm Indication Signaling (AIS), Bipolar Violation (BPV), Loss of Signal (LOS) and Out Of Frame (OOF) errors. In addition, the module extracts Synchronization Status Messages (SSMs) from the incoming data.

The E1 Input module receives signals and performs phase measurement comparisons (at a sampling rate of 40 Hz) with the Clock modules that are installed in the SSU-2000e. The Clock modules use this information to phase lock to the incoming signal. The data may also be used for monitoring the frequency of incoming signals.

Functional Block Diagram

A simplified block diagram of the 1- and 3-Port Input module is shown in [Figure 7-1](#).

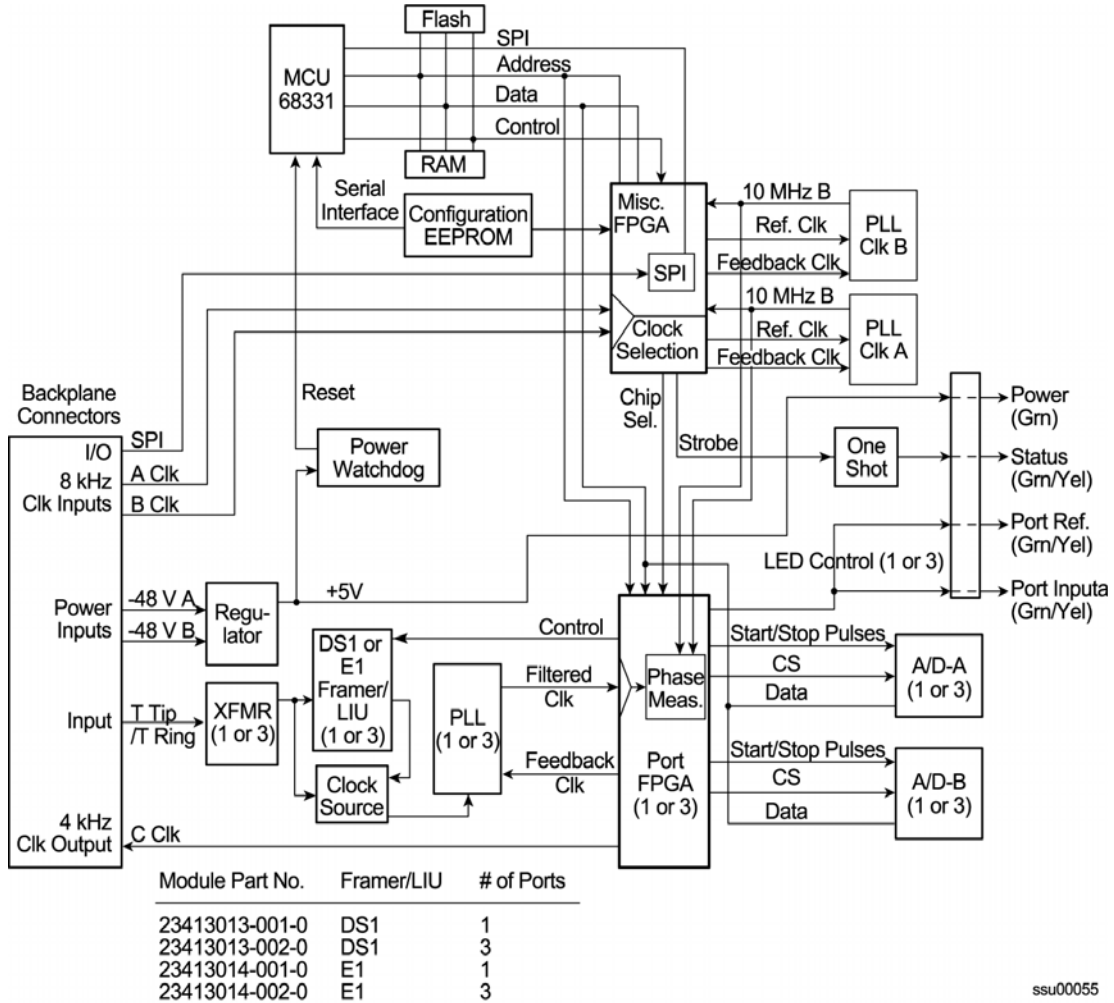

Figure 7-1. Block Diagram of the 1-Port and 3-Port E1 Input Modules

Phase Measurement Averages

The Input module also maintains averages of past phase measurements including:

- 7000 100-second averages
- 700 1000-second averages
- 70 10000-second averages

To account for momentary jumps in phase, the Input module uses a phase buildout algorithm for phase jumps greater than or equal to 1 microsecond per tenth of a second. To prevent confusing frequency offsets with phase jumps, the phase build out algorithm does not build out more than eight consecutive samples. If the phase is *built out*, the Input module sends an event message to the Communications module.

The firmware running in the E1 Input module performs the following functions:

- Determines module type (distinguishes between E1 and DS1 frame chips)

- Supports unframed clock signals at the following rates: 1 MHz, 1.544 MHz, 2.048 MHz, 5.0 MHz, 10.0 MHz
- Enables/disables the Input module on command (when disabled, it does not report any alarms or measurement data and blinks the STATUS LED repeatedly)
- Enables or disables individual ports on command (disabled ports clear all existing alarms and do not report any additional alarms or measurement data)
- Maintains a provisioned SSM for each port
- Stores a priority for each port

Three-Sigma Test

The Input module uses a three-sigma test as part of the phase averaging algorithm in order to avoid the use of erroneous phase readings. In such tests, the standard deviation sigma of the phase readings is maintained. Any reading which falls more than three sigma above or below the mean is considered erroneous.

MTIE Calculation

MTIE is a measurement of the relative noisiness of an input signal. The Input module automatically (without user intervention) calculates MTIE for its inputs in accordance with the specifications in ANSI T1.101 and reported on demand for a 24 hour period.

MTIE data is retrieved on hour boundaries, though the stop time used may be current time. Reported time periods include: 0.05, 0.1, 1.0, 10.0, 100.0, 1000.0, 10000.0, and 100000.0 seconds.

MTIE Alarms

The input module monitors the ongoing MTIE calculations and logs an alarm if the MTIE calculation for any of several window sizes exceeds user-set masks.

The Input module software maintains two alarm masks, each with thresholds at 10, 100, 1000, 10,000, and 100,000 seconds. MTIE readings which violate either mask at any point cause an alarm at a user-set level (Minor, Major, or Critical). Refer to [Changing Factory Defaults](#), on page 114, for more information on setting alarm levels.

Although MTIE is continuously calculated against both clocks, MTIE alarms are logged only if the measurements against the currently selected clock violate one of the MTIE alarm masks.

TDEV Calculation

The Input module automatically (without user intervention) calculates TDEV (the measurement of the frequency components in a series of phase readings) for all its inputs and reports on the past 24 hours of TDEV history. TDEV is retrieved on hour boundaries, though the stop time used may be the current time.

Reported time periods include: 0.05, 0.10, 0.30, 0.60, 1.0, 2.0, 3.0, 6.0, 10.0, 30.0, 60.0, 100.0, 300.0, 600.0, 1000.0, 3000.0, 6000.0, and 10000.0 seconds.

The E1 Input module also contains provisions for *zeroing* the phase readings for one channel in response to a command from the Communications module. Once the phase is zeroed, all subsequent phase measurements are expressed in terms of how much they differ from the reading at the time the phase was zeroed.

Zeroing the phase invalidates all past phase averages, TDEV, and MTIE.

Sync Status Messages

The E1 Input module reads and processes Sync Status Messages (in accordance with applicable parts of ITU-T G.781 and with T1X1.3 TR33, ANSI T1.101-1999, and Telcordia Technologies GR-253 and 378-CORE) to determine the traceability of inputs. This traceability information is then used by the Clock modules in selecting a reference signal and is embedded into the system’s outputs. For E1 inputs, an SSM is valid if three consecutive matching SSMs are received.

E1 Input Module Alarm Modes

The E1 Input module responds to various alarm conditions according to user-set alarm levels. Each level is associated with a set of actions (or non-actions) as shown in [Table 7-1](#).

Table 7-1. E1 Input Module Alarm Modes

Alarm Mode	Action	Alarm Elevation
IGNORE	Do nothing	Cannot be elevated to a higher severity level
REPORT	Do nothing	Cannot be elevated to a higher severity level
MINOR	Generate event message	Elevate to MAJOR if the alarm condition persists beyond the user-set elevation time limit
MAJOR	Generate event message	Elevate to Critical if the alarm condition persists beyond the user-set elevation time limit
CRITICAL	<ul style="list-style-type: none"> ■ Generate event message ■ Fault Port 	Cannot be elevated to a higher severity level

SSM Selection Criteria

If the E1 Input module is configured for provisioned mode, it will use the provisioned SSM. If configured for automatic mode, the Input module uses the most recent valid SSM. If a valid SSM is not received, the module uses the provisioned SSM. Refer to the *SSU-2000e Technical Reference* for more information on provisioning SSMs.

Alarms Caused by Hardware Problems

The following alarms are generated due to hardware problems occur:

- External Clock Signal PLL Unlocked
 - Report event message and perform any other actions as required by the user-set severity level
 - Fault channel, even if severity is less than MAJOR
 - Monitor PLL for recovery
- Input Signal PLL Unlocked
 - Report event message and perform other actions as required by severity
 - Fault port, regardless of severity
 - Monitor PLL for recovery
- Phase Measurement Circuitry Fault
 - Report event message and perform any other required actions
 - Fault Port
 - Monitor phase hardware for recovery

Alarms Caused by Faulty Input Signals

The following alarms are caused by problems with the incoming input signal's formatting or content:

- Errors Tracked:
 - Framed signals: LOS, AIS, OOF, BPV and CRC
 - Unframed signals: LOS
- Error and Clear Counters

The E1 Input module maintains a count of the number of consecutive errored seconds for each error type for each port. Once this *error count* exceeds a user-set limit, the input signal which has experienced the errors is said to be *in episode*. Refer to [Changing Factory Defaults](#), on page 114, for more information on setting the *error count*.

The Input module maintains a count of the number of consecutive seconds in which the input signal for each port was free of each type of error. This *clear count* must exceed a user-set limit before the input signal is no longer in episode. Refer to [Changing Factory Defaults](#), on page 114, for more information on setting the *clear count*.

Handling Input Signal Faults

For LOS (loss of signal) and before going into episode:

- Coast over brief occurrences of LOS, reporting the last known good phase measurements for the port until signal returns or the signal goes into episode.
- The duration of a *brief* occurrence of LOS is defined by the value of the error count for LOS. The default is 10 seconds.

Once in episode:

- Log LOS alarm, taking appropriate action per the assigned severity level
- Invalidate current phase measurements
- Others (AIS, BPV, CRC, and OOF)

Once in episode, the system takes appropriate action according to the severity level assigned to the alarm.

LOS Phase Considerations

- Phase reading not valid when in episode
- Zero phase reading when episode ends
- If the input signal returns before the port goes into episode, normalize subsequent phase measurements to show continuous phase numbers before and after the loss of signal
- Others
- Phase reading valid

Hierarchy of Alarm Signals

- LOS
- AIS
- OOF
- BPV/CRC

The Input module does not report alarms below the level of an active alarm.

Cesium Fault

- Facilitates compatibility with older Hewlett Packard units
- Only valid if port one is configured to receive an unframed input signal
- User can select high or low logic level as alarmed
- If the hardware indicates that the cesium fault level matches the *alarmed* setting, log an AIS alarm against port 1
- Clear the alarm when the hardware's cesium fault level no longer matches the alarmed level

Input Measurement Problems

If the MTIE values for a selected clock exceed either of the MTIE masks, the Input module takes appropriate action according to the severity level associated with the MTIE alarms.

If a received SSM has a lower PQL than the provisioned value assigned to the port and the port has SSMs enabled, the Input module performs the action required by the alarm mode.

E1 Input Module Events Reported

The E1 Input module reports the event types listed in [Table 7-2](#) when they occur:

Table 7-2. E1 Input Module Event Reporting

Event	Parameter One	Parameter Two
Module installed	–	–
Module enabled	–	–
Module disabled	–	–
Module restarted	Delay before restart (in Seconds)	–
Input Signal Episode, Alarm, and Faults	–	–
Hardware Faults	–	–
Received SSM Changed	New PQL	Old PQL
Phase Buildout	Phase value being built out	<i>Corrected</i> phase value
Configuration Changes	New Value (if necessary)	Old Value (if not implied by new value)
Input phase zeroed	–	–

Status LED Indicators

The E1 Input module is equipped with a set of status LED indicators that indicate module and incoming signal status. These LEDs are shown in [Figure 7-2](#) (3-port model illustrated) and described in [Table 7-3](#).

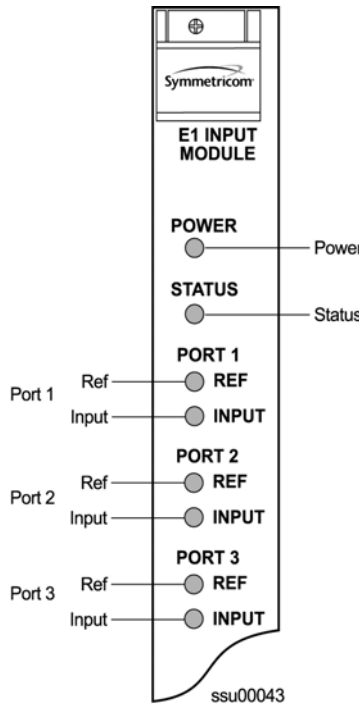

Figure 7-2. Front Panel of the E1 Input Module

Table 7-3. E1 Input Module Status LED Indicators

Indicator	Color	Description
POWER	Green	On = The module is receiving +5 V DC
STATUS	Green/Amber	Green = Unit is in Normal mode of operation; no faults Amber = Fault condition detected Blinking (Amber) = Firmware downloading or module disabled
PORT 1 REF	Green	On = Selected Reference Off = Disabled, or good and not selected
PORT 1 INPUT	Green/Amber	On (Green) = Enabled and signal valid, no major alarms On (Amber) = Enabled and signal not valid Off = Disabled
PORT 2 REF	Green	On = Selected Reference Off = Disabled, or good and not selected
PORT 2 INPUT	Green/Amber	On (Green) = Enabled and signal valid, no major alarms On (Amber) = Enabled and signal not valid Off = Disabled
PORT 3 REF	Green	On = Selected Reference Off = Disabled, or good and not selected
PORT 3 INPUT	Green/Amber	On (Green) = Enabled and signal valid, no major alarms On (Amber) = Enabled and signal not valid Off = Disabled

Configuration Options

The E1 input module maintains factory default and current user configuration information in nonvolatile memory. This information is retrieved at power up and modified by commands from the Communications module. In the event that the current user configuration cannot be used, the module automatically reverts to factory defaults.

The factory settings and ranges for all E1 Input module software parameters are listed in [Table 7-4](#).

Table 7-4. E1 Input Module Configuration

Configuration Setting	Factory Default	Range
Framing Enabled	On/On/Off	On Off
Input Frequency (for unframed signals)	10 MHz	1 MHz 1.544 MHz 2.048 MHz 5 MHz 10 MHz
Framing Type	CCS	CAS CCS
Zero Suppression	On	On Off
CRC	Off	On Off
SSM	Off	On Off
Provisioned PQL	3/4/3	1 to 16
Priority	0	0 to 10 (0 = Monitor)
E1 Bit Position	8	4 to 8
Cesium Fault Nominal	Low	Low High Off
Input Signal Error Limit	10 seconds	1 to 100 for LOS and AIS, 1 to 10 000 for BPV, CRC and OOF
FREQ Set Clk A	16 000	0 to 10 000 000
FREQ Set Clk B	16 000	0 to 10 000 000
FREQ Clear Clk A	12 000	0 to 10 000 000
FREQ Clear Clk B	12 000	0 to 10 000 000
Frequency Alarm Mode	Major	Ignore Report Minor Major Critical
MTIE T10 Set Limit1	80	0 to 60 000
MTIE T10 Set Limit2	100	0 to 60 000
MTIE T100 Set Limit1	800	0 to 60 000
MTIE T100 Set Limit 2	1000	0 to 60 000
MTIE T1K Set Limit1	1600	0 to 60 000

Table 7-4. E1 Input Module Configuration (Continued)

Configuration Setting	Factory Default	Range
MTIE T1K Set Limit2	2000	0 to 60 000
MTIE T10K Set Limit 1	2270	0 to 60 000
MTIE T10K Set Limit 2	2835	0 to 60 000
MTIE T100K Set Limit 1	4260	0 to 60 000
MTIE T100K Set Limit 2	5330	0 to 60 000
MTIE T10 Clear Limit1	70	0 to 60 000
MTIE T10 Clear Limit2	90	0 to 60 000
MTIE T100 Clear Limit1	700	0 to 60 000
MTIE T100 Clear Limit 2	900	0 to 60 000
MTIE T1K Clear Limit1	1400	0 to 60 000
MTIE T1K Clear Limit2	1800	0 to 60 000
MTIE T10K Clear Limit 1	2000	0 to 60 000
MTIE T10K Clear Limit 2	2500	0 to 60 000
MTIE T100K Clear Limit 1	3800	0 to 60 000
MTIE T100K Clear Limit 2	4800	0 to 60 000
MTIE Limit 1 Alarm Mode	Minor	Ignore Report Minor Major Critical
MTIE Limit 2 Alarm Mode	Major	Ignore Report Minor Major Critical
Alarm Initial Severity	Minor (except LOS and level 2 MTIE, which are Major)	Ignore Report Minor Major Critical
Alarm Initial Delay	0 s	0 to 86 400 s
Alarm Elevation Time	86 400 s	0 to 500 000 s, 0 is disabled
Port Status	Disabled	Enabled Disabled
Port Name		Any user-selected string from 0 – 20 characters

1-Port and 3-Port DS1 Input Modules

This section describes the 1-port (part number 23413013-001-0) and 3-port (part number 23413013-002-0) DS1 Input modules that may be installed in an SSU-2000e.

The 1-Port and 3-port DS1 Input modules receive signals and perform phase measurement comparisons with the Clock modules that are installed in the SSU-2000e. The Clock modules use this information to phase and frequency lock to the incoming signal. The data may also be used for monitoring the frequency of incoming signals.

The input ports accept one (1-Port Input modules), or three (3-Port Input modules) of the following signals: sine or square wave, with frequency of 1, 1.544, 2.048, 5 or 10 MHz, or framed communication type DS1. If the input signal is a communications type, the module monitors for Alarm Indication Signaling (AIS), Bipolar Violations (BPVs), Loss of Signal (LOS) and Out Of Frame (OOF) errors. In addition, the module extracts Synchronization Status Messages (SSMs) from the incoming data.

Functional Overview

The DS1 Input module (1-port and 3-port versions) consists of a microcontroller and firmware, SRAM for data storage, FLASH (contains the firmware), input signal ports, and other support circuitry. The primary function of these modules is to perform time-interval-measurements on Clock module A and Clock module B, using the reference input signals. These measurements are used to adjust the frequency of the oscillators on the two Clock modules.

Functional Block Diagram

A simplified block diagram of the 1- and 3-Port Input modules is shown in [Figure 7-3](#).

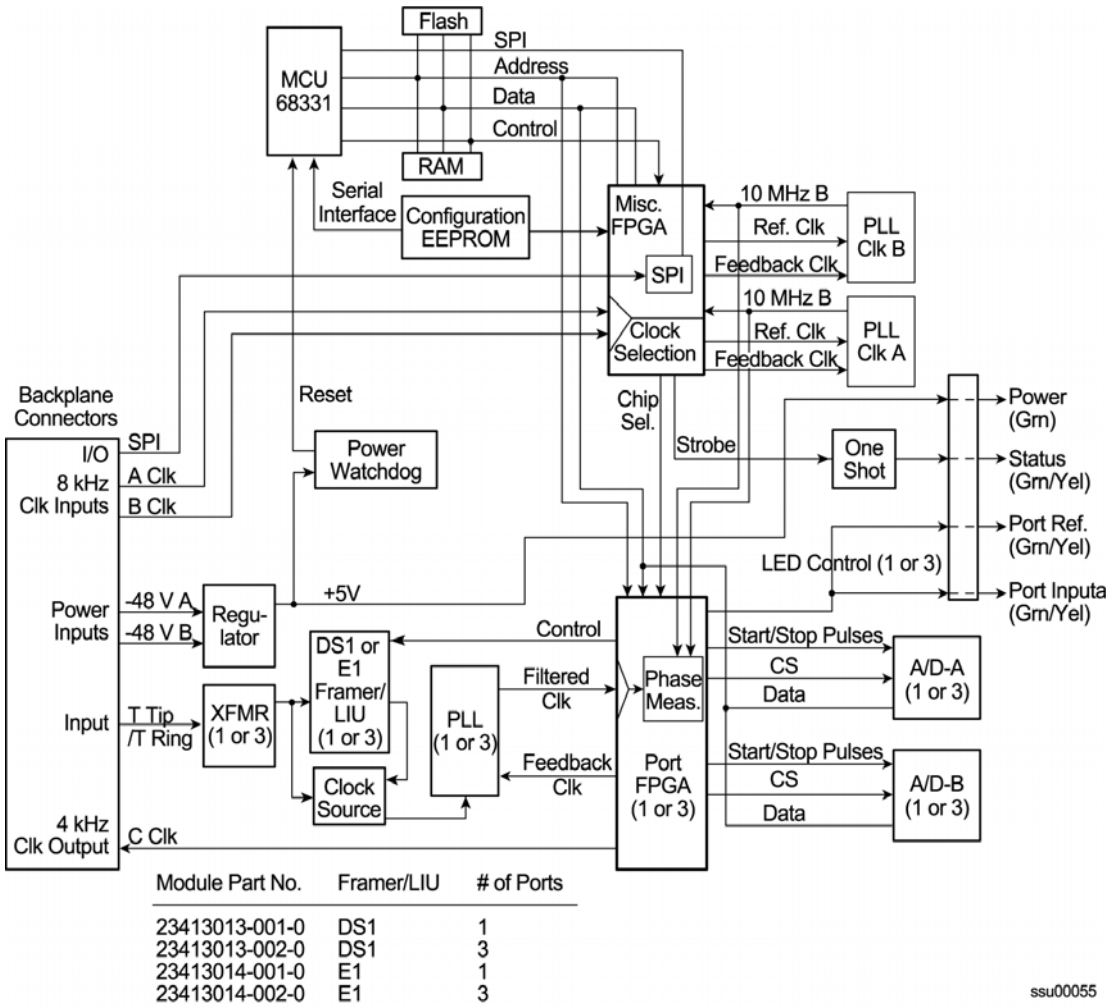

Figure 7-3. Block Diagram of the 1-Port and 3-Port DS1 Input Module

Phase Measurement Averages

The Input module also maintains averages of past phase measurements including:

- 1000 one-second averages
- 1000 100-second averages
- 100 1000-second averages
- 10 10000-second averages

To account for momentary jumps in phase, the Input module uses a phase buildout algorithm for phase jumps greater than or equal to 1 microsecond per tenth of a second. To prevent confusing frequency offsets for phase jumps, the phase build-out algorithm does not build-out more than eight consecutive samples. If the phase is *built out*, the Input module sends an event message to the Communications module.

Three-Sigma Test

The Input module uses a three-sigma test as part of the phase averaging algorithm in order to avoid the use of erroneous phase readings. In such tests, the standard deviation sigma of the phase readings is maintained. Any reading which falls more than three sigma above or below the mean is considered erroneous.

MTIE Calculation

MTIE is a measurement of the relative noisiness of an input signal. The Input module automatically (without user intervention) calculates MTIE for its inputs in accordance with the specifications in (ANSI) T1.101 and reported on demand for a 24 hour period.

MTIE data is retrieved on hour boundaries, though the stop time used may be current time. Reported time periods include 0.05, 0.1, 1.0, 10.0, 100.0, 1000.0, 10000.0, and 100000.0 seconds.

MTIE Alarms

The Input module monitors the ongoing MTIE calculations and logs an alarm if the MTIE calculation for any of several window sizes exceeds user-set masks.

The Input module software maintains two alarm masks, each with thresholds at 10, 100, 1000, 10,000, and 100,000 seconds. MTIE readings which violate either mask at any point cause an alarm at a user-settable level (Minor, Major, or Critical). Refer to [Changing Factory Defaults](#), on page 114, for more information on setting alarm levels.

Although MTIE is continuously calculated against both clocks, MTIE alarms are logged only if the measurements against the currently selected clock violate one of the MTIE alarm masks.

TDEV Calculation

The Input module automatically (without user intervention) calculates TDEV (the measurement of the frequency components in a series of phase readings) for all its inputs and reports on the past 24 hours of TDEV history. TDEV is retrieved on hour boundaries, though the stop time used may be current time.

Reported time periods include 0.05, 0.10, 0.30, 0.60, 1.0, 2.0, 3.0, 6.0, 10.0, 30.0, 60.0, 100.0, 300.0, 600.0, 1000.0, 3000.0, 6000.0, and 10,000.0 seconds.

The input card also contains provisions for *zeroing* the phase readings for one channel in response to a command from the Communications module. Once the phase is zeroed, all subsequent phase measurements are expressed in terms of how much they differ from the reading at the time the phase was zeroed.

Zeroing the phase invalidates all past phase averages, TDEV, and MTIE.

Synchronization Status Messages

The Input module reads and processes Synchronization Status Messages (in accordance with specifications ANSI T1.403 for DS1 signals), to determine the traceability of inputs. This traceability information is then used by the Clock modules in selecting a reference signal and embedded into the system's outputs.

For a DS1 input signal, an SSM is considered valid only after seven of the last ten received SSMs match. For DS1 signals, the Input module logs an alarm (user-set level) if 10 seconds elapse and no SSM is detected.

SSM Selection Criteria

If the Input module is configured for provisioned mode, it will use the provisioned SSM. If configured for automatic mode, the Input module uses the most recent valid SSM. If a valid SSM is not received, the module uses the provisioned SSM. Refer to [Changing Factory Defaults](#), on page 114, for more information on SSM settings.

DS1 Input Module Alarm Modes

The Input module responds to various alarm conditions according to user-set alarm levels. Each level is associated with a set of actions (or non-actions) as shown in [Table 7-5](#).

Table 7-5. DS1 Input Module Alarm Modes

Alarm Mode	Action	Alarm Elevation
IGNORE	Do nothing	Cannot be elevated to a higher severity level
REPORT	Generate event message	Cannot be elevated to a higher severity level
MINOR	Generate event message	Elevate to MAJOR if the alarm condition persists beyond the user-settable elevation time limit
MAJOR	Generate event message	Elevate to Critical if the alarm condition persists beyond the user-settable elevation time limit
CRITICAL	<ul style="list-style-type: none"> ■ Generate event message ■ Fault Port 	Cannot be elevated as there is no higher severity level

Alarms Caused by Hardware Problems

The following alarms are generated due to hardware problems:

- External Clock Signal PLL Unlocked
 - Report event message and perform any other actions as required by the user-set severity level
 - Fault channel, even if severity is less than MAJOR
 - Monitor PLL for recovery

- Input Signal PLL Unlocked
 - Report event message and perform other actions as required by severity
 - Fault port, regardless of severity
 - Monitor PLL for recovery
- Phase Measurement Circuitry Fault
 - Report event message and perform any other required actions
 - Fault Port
 - Monitor phase hardware for recovery

Handling Input Signal Faults

The following alarms are caused by problems with the incoming input signal's formatting or content:

- Errors Tracked:
 - Framed signals: LOS, AIS, OOF, BPV and CRC
 - Unframed signals: LOS
- Error and Clear Counters

The Input module maintains a count of the number of consecutive errored seconds for each error type for each port. Once this *error count* exceeds a user-set limit, the input signal which has experienced the errors is said to be *in episode*.

The Input module maintains a count of the number of consecutive seconds in which the input signal for each port was free of each type of error. This *clear count* must exceed a user-set limit before the input signal is no longer in episode.

Handling Input Signal Faults

For LOS (loss of signal) and before going into episode:

- Coast over brief occurrences of LOS, reporting the last known good phase measurements for the port until signal returns or the signal goes into episode.
- The duration of a *brief* occurrence of LOS is defined by the value of the error count for LOS.

Once in episode:

- Log LOS alarm, taking appropriate action per the assigned severity level
- Invalidate current phase measurements
- Others (AIS, BPV, CRC, and OOF)
- Once in episode, take appropriate action according to the severity level assigned to the alarm

LOS Phase Considerations

- Phase reading not valid when in episode
- Zero phase reading when episode ends
- If signal returns before the port goes into episode, normalize subsequent phase measurements to show continuous phase numbers before and after the loss of signal.
- Others
- Phase reading valid

Hierarchy of Signal Faults

The following alarms are listed in the order of most to least severe:

- LOS
- AIS
- OOF
- BPV/CRC

The Input module does not report alarms below the level of an active alarm.

Cesium Fault

- Facilitates compatibility with older Hewlett Packard units
- Only valid if port one is configured to receive an unframed input signal
- User can select high or low logic level as alarmed
- If the hardware indicates that the cesium fault level matches the *alarmed* setting, log an AIS alarm against port 1.
- Clear the alarm when the hardware's cesium fault level no longer matches the alarmed level.

Input Measurement Problems

If the MTIE values for a selected clock exceed either of the MTIE masks, the Input module takes appropriate action according to the severity level associated with the MTIE alarms. If a received SSM has a lower PQL than the provisioned value assigned to the port and the port has SSMs enabled, the Input module performs the action required by the alarm mode. The action depends on the alarm mode set by the user or the default settings. Refer to the Alarm command in the *SSU-2000e Technical Reference* for more information on alarm settings.

DS1 Input Module Events Reported

The 3-Port DS1 Input module reports the event types listed in [Table 7-6](#) when they occur:

Table 7-6. DS1 Input Module Event Reporting

Event	Parameter One	Parameter Two
Card installed	–	–
Card enabled	–	–
Card disabled	–	–
Card restarted	Delay before restart (in Seconds)	–
Input Signal Episode, Alarm, and Faults	–	–
Hardware Faults	–	–
Received SSM Changed	New PQL	Old PQL
Phase Buildout	Phase value being built out	<i>Corrected</i> phase value
Configuration Changes	New Value (if necessary)	Old Value (if not implied by new value)
Input phase zeroed	–	–

Status LED Indicators

The DS1 Input module is equipped with eight status LEDs that indicate module status. These LEDs are shown in [Figure 7-4](#) and are described in [Table 7-7](#).

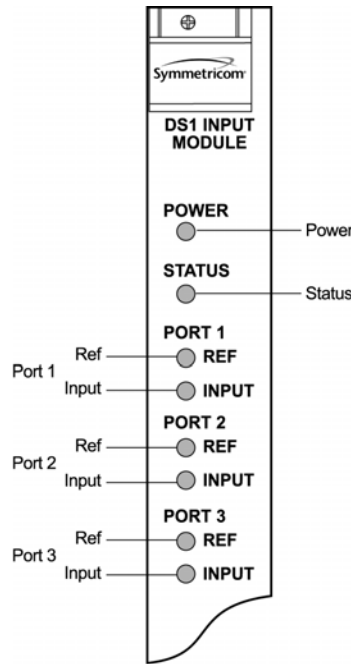

Figure 7-4. Front Panel of the DS1 Input Module

Table 7-7. DS1 Input Module Status LED Indicators

Indicator	Color	Description
POWER	Green	On = The module is receiving +5 VDC
STATUS	Green/Amber	Green = Unit is in Normal mode of operation; no faults Amber = Fault condition detected Blinking (Amber) = Firmware downloading or module disabled
PORT 1 REF	Green	On = Selected Reference Off = Disabled, or good and not selected
PORT 1 INPUT	Green/Amber	On (Green) = Enabled and signal valid, no major alarms On (Amber) = Enabled and signal not valid Off = Disabled
PORT 2 REF	Green	On = Selected Reference Off = Disabled, or good and not selected
PORT 2 INPUT	Green/Amber	On (Green) = Enabled and signal valid, no major alarms On (Amber) = Enabled and signal not valid Off = Disabled
PORT 3 REF	Green	On = Selected Reference Off = Disabled, or good and not selected
PORT 3 INPUT	Green/Amber	On (Green) = Enabled and signal valid, no major alarms On (Amber) = Enabled and signal not valid Off = Disabled

Configuration Options

The DS1 input module maintains factory default and current user configuration information in nonvolatile memory. This information is retrieved at power up and can be modified by commands from the Communications module. In the event that the current user configuration cannot be used, the module automatically reverts to factory defaults.

The factory settings and ranges for all DS1 Input module software parameters are listed in [Table 7-8](#).

Table 7-8. DS1 Input Module Configuration

Configuration Setting	Factory Default	Range
Framing Enabled	On/On/Off	On Off
Input Frequency (for unframed signals)	10 MHz	1 MHz 1.544 MHz 2.048 MHz 5 MHz 10 MHz
Framing Type	ESF	D4 or ESF
Zero Suppression	On	On Off
CRC	Off	On Off
SSM	Off	On Off
Provisioned PQL	3/4/3	1 to 16
Priority	0	0 to 10, 0 is Monitor
Cesium Fault Nominal	Low	Low High Off
Input Signal Error Limit	10 s	1 to 100 for LOS and AIS 1 to 10000 for BPV, CRC, and OOF
FREQ Set Clk A	16 000	0 to 10 000 000
FREQ Set Clk B	16 000	0 to 10 000 000
FREQ Clear Clk A	12 000	0 to 10 000 000
FREQ Clear Clk B	12 000	0 to 10 000 000
Frequency Alarm Mode	Major	Ignore Report Minor Major Critical
MTIE T10 Set Limit1	260	0 to 60 000
MTIE T10 Set Limit2	325	0 to 60 000
MTIE T100 Set Limit1	440	0 to 60 000
MTIE T100 Set Limit 2	550	0 to 60 000
MTIE T1K Set Limit1	810	0 to 60 000
MTIE T1K Set Limit2	1010	0 to 60 000

Table 7-8. DS1 Input Module Configuration (Continued)

Configuration Setting	Factory Default	Range
MTIE T10K Set Limit 1	880	0 to 60 000
MTIE T10K Set Limit 2	1100	0 to 60 000
MTIE T100K Set Limit 1	1600	0 to 60 000
MTIE T100K Set Limit 2	2000	0 to 60 000
MTIE T10 Clear Limit1	230	0 to 60 000
MTIE T10 Clear Limit2	290	0 to 60 000
MTIE T100 Clear Limit1	400	0 to 60 000
MTIE T100 Clear Limit 2	490	0 to 60 000
MTIE T1K Clear Limit1	730	0 to 60 000
MTIE T1K Clear Limit2	910	0 to 60 000
MTIE T10K Clear Limit 1	790	0 to 60 000
MTIE T10K Clear Limit 2	990	0 to 60 000
MTIE T100K Clear Limit 1	1440	0 to 60 000
MTIE T100K Clear Limit 2	1800	0 to 60 000
MTIE Limit 1 Alarm Mode	Minor	Ignore, Report, Minor, Major, or Critical
MTIE Limit 2 Alarm Mode	Major	Ignore, Report, Minor, Major, or Critical
Alarm Initial Severity	Minor (except LOS and level 2 MTIE, which are Major)	Ignore, Report, Minor, Major, or Critical
Alarm Initial Delay	0 s	0 to 86 400 s
Alarm Elevation Time	86 400 s	60 to 500 000 s, 0 is disabled
Port Status	Disabled	Enabled Disabled
Port Name		User-selected string from 0 – 20 characters

GPS Input Module

This section provides user-reference data for the GPS Input module (part number 23413019-000-0) that is used in the SSU-2000e main chassis to provide a timing reference signal to phase and frequency lock the internal clocks and to produce phase locked output signals. For information on antenna kits and accessories, including part numbers and installation procedures, refer to the *SSU-2000e Technical Reference*.

GPS Input Module Functional Overview

The module consists of a Micro-controller and firmware, SRAM for data storage, FLASH which contains the firmware, a GPS receiver (radio), and other support circuitry. The primary function of these module is to perform time-interval measurements on Clock module A and Clock module B, using the 1PPS provided by the radio. These measurements are used to adjust the frequency of the oscillators on those modules.

In addition, this module supports the Network Time Protocol (NTP), which is a function provided by the Communications module. Time-of-day from the Radio is transferred to the Communications module for distribution to *clients* connected to the same network. The Communications module's internal 1PPS is synchronized to the 1PPS from the Radio.

The GPS Input module monitors and reports the status and performance of the module and the received radio signals. The module communicates with the Communications module to receive user configuration commands and to report status and performance back to the Clock modules for frequency control.

Functional Block Diagram

A simplified block diagram of the GPS Input module is shown in [Figure 7-5](#).

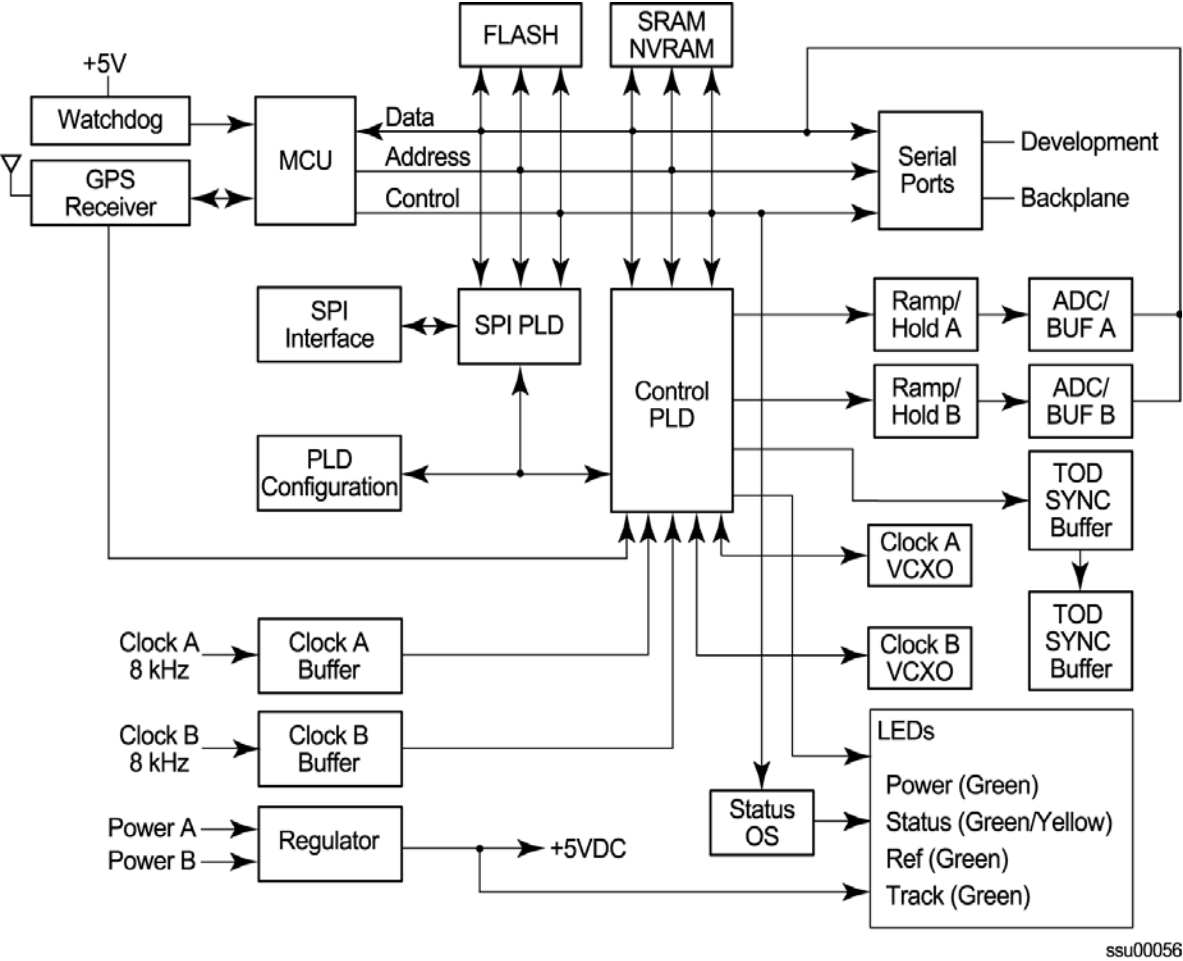

Figure 7-5. Block Diagram of the GPS Input Module

Status LED Indicators

The GPS Input module is equipped with four status LEDs as shown in [Figure 7-6](#). The LED status assignments are described in [Table 7-9](#).

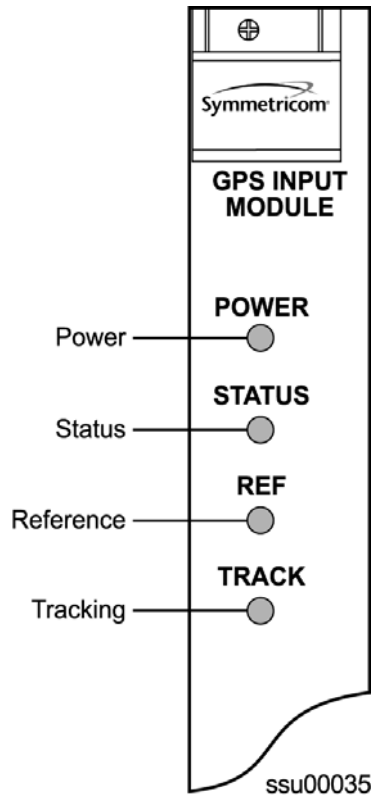

Figure 7-6. Front Panel of the GPS Input Module

Table 7-9. GPS Input Module Status LED Indicators

Indicator	Color	Description
POWER	Green	On = The module is receiving +5 V DC
STATUS	Green/Amber	Green = Unit is in Normal mode of operation; no faults Amber = Fault condition detected (firmware timed out) Blinking (Amber) = Firmware uploading or antenna not connected
REF	Green	On = Selected as the clock reference Off = Not selected as the reference
TRACKI	Green/Amber	On (Green) = RADIO is tracking On (Amber) = Tracking problem without antenna fault Blinking (Amber) = Antenna fault

Configuration Options

The configuration settings for the GPS Input module is provided in [Table 7-10](#).

Table 7-10. GPS Input Module Configuration Settings

Configuration Setting	Factory Default	Range
Position (GPS only)		
Latitude	0	± 90 degrees
Longitude	0	±180 degrees
Altitude	0	-60 to 4000 meters
Averages	300	10 to 3600
PDOP	0	1 to 10
Pos Mode	Calc	User Calc
Min Elevation for position	5	0 to 50 degrees
Min PDOP for position	3	1 to 10
Min Elevation for timing	10	0 to 50 degrees
Module Status	Enabled	Enabled Disabled
Priority	0	0 to 10
Sigma limit	25	10 to 1000 μ s
PQL	2	1 to 16
Disabled SV list	None	Up to 31 SV numbers
Min PDOP for position	3	1 to 10
FREQ Set Clk A	16 000	0 to 10 000 000
FREQ Set Clk B	16 000	0 to 10 000 000
FREQ Clear Clk A	12 000	0 to 10 000 000
FREQ Clear Clk B	12 000	0 to 10 000 000
Frequency Alarm Mode	Major	Ignore Report Minor Major Critical
MTIE T10 Set Limit1	260	0 to 60 000
MTIE T10 Set Limit2	325	0 to 60 000
MTIE T100 Set Limit1	440	0 to 60 000
MTIE T100 Set Limit 2	550	0 to 60 000
MTIE T1K Set Limit1	810	0 to 60 000
MTIE T1K Set Limit2	1010	0 to 60 000
MTIE T10K Set Limit 1	880	0 to 60 000
MTIE T10K Set Limit 2	1100	0 to 60 000

Table 7-10. GPS Input Module Configuration Settings (Continued)

Configuration Setting	Factory Default	Range
MTIE T100K Set Limit 1	1600	0 to 60 000
MTIE T100K Set Limit 2	2000	0 to 60 000
MTIE T10 Clear Limit1	230	0 to 60 000
MTIE T10 Clear Limit2	290	0 to 60 000
MTIE T100 Clear Limit1	400	0 to 60 000
MTIE T100 Clear Limit 2	490	0 to 60 000
MTIE T1K Clear Limit1	730	0 to 60 000
MTIE T1K Clear Limit2	910	0 to 60 000
MTIE T10K Clear Limit 1	790	0 to 60 000
MTIE T10K Clear Limit 2	990	0 to 60 000
MTIE T100K Clear Limit 1	1440	0 to 60 000
MTIE T100K Clear Limit 2	1800	0 to 60 000
MTIE Limit 1 Alarm Mode	Minor	Ignore Report Minor Major Critical
MTIE Limit 2 Alarm Mode	Major	Ignore Report Minor Major Critical

Composite Clock Input Module

This section provides operating instructions and software provisioning procedures for the Composite Clock Input module (part number 23413279-000-0), designed for use in the SSU-2000e Synchronization Supply Unit.

Functional Overview

The Composite Clock Input module conditions a composite clock input signal that is used to control the frequency of the Clock modules. In Subtending mode (either ANSI or Japanese), it also produces a 4 kHz synchronization signal, which determines the phase of the composite clock signals generated by Composite Clock Output modules. This signal ensures that the phase of the composite clock output signals follow the phase of the composite clock input reference signal. The module consists of a micro-controller and firmware, SRAM for data storage, FLASH memory that contains the firmware, and other support circuitry.

The module monitors and reports module status and conditions. Events are generated for Loss of Signal (LOS) and Bipolar Violation (BPV) density. Each module communicates with the Communications module to receive user configuration commands and to report status and performance for the Clock modules for frequency control.

Functional Block Diagram

A simplified block diagram of the Composite Clock Input module is shown in [Figure 7-7](#).

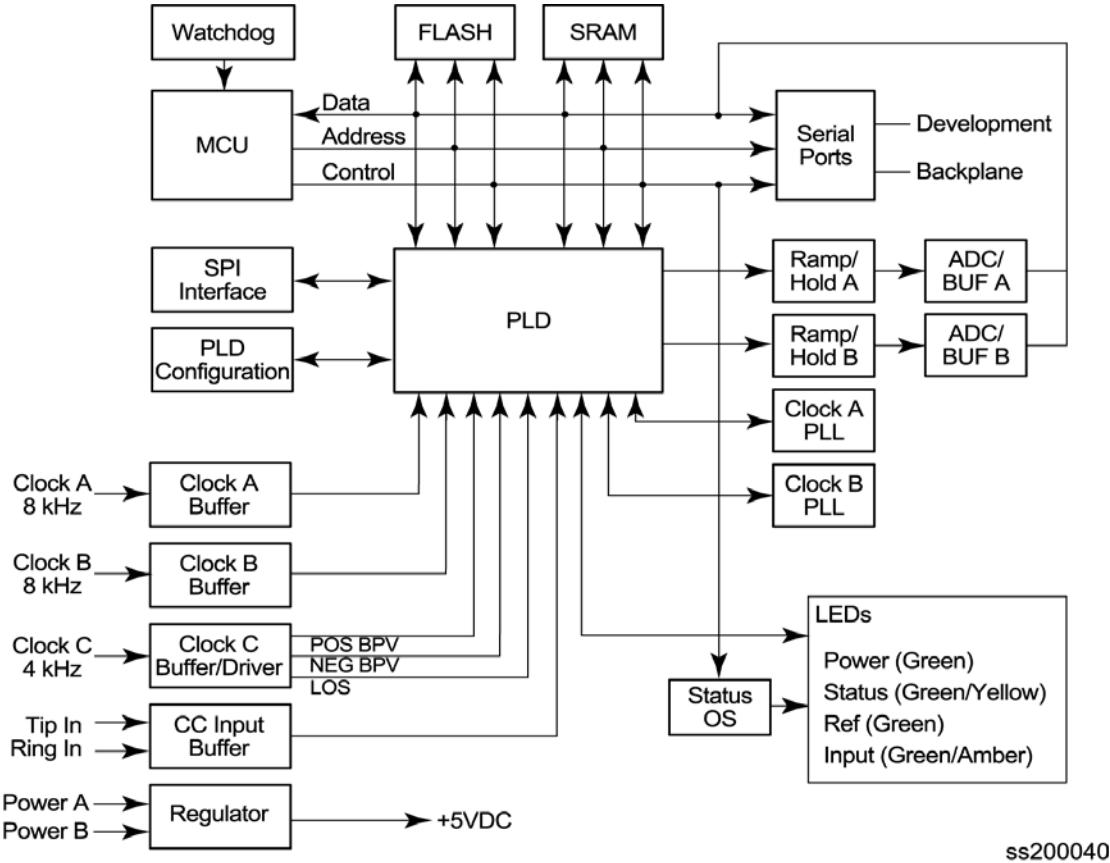

Figure 7-7. Block Diagram of the Composite Clock Input Module

Status LED Indicators

The CC Input module is equipped with four status LEDs as shown in [Figure 7-8](#). The LED status assignments are described in [Table 7-9](#).

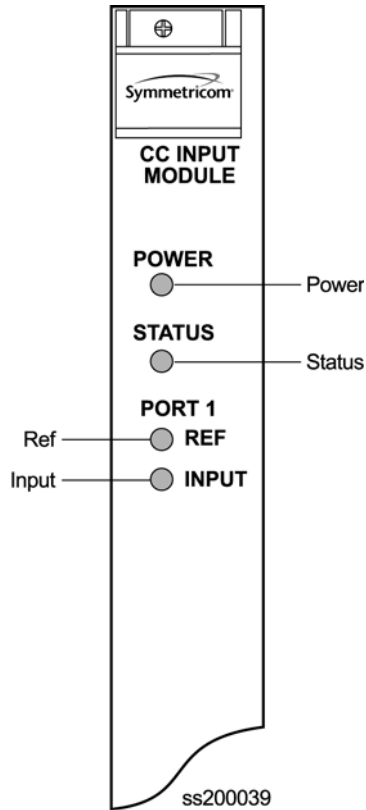

Figure 7-8. Front Panel of the Composite Clock Input Module

Table 7-11. Composite Clock Input Module Status LED Indicators

Indicator	Color	Description
POWER	Green	On = The module is receiving +5 VDC
STATUS	Green/Amber	Green = Unit is in Normal mode of operation; no faults Amber = Fault condition detected Blinking = Disabled or firmware upgrade in progress
REF	Green	On = Selected as the input reference Off = Not selected as the reference
INPUT	Green/Amber	On (Green) = Enabled and signal valid (no major alarms) On (Amber) = Enabled and signal not valid Off = Disabled

Configuration Options

The configuration settings for the Composite Clock Input module are listed in [Table 7-12](#).

Table 7-12. Composite Clock Input Module Configuration Settings

Configuration Setting	Factory Default	Range
Provisioned PQL	4	1 to 16
Priority	0	1 to 10, 0 is Monitor
Input Signal Error Limit	LOS = 1 BPV = 1	LOS: 1 to 100 BPV: 1 to 100 000
Input Signal Clear Limit	LOS = 5 BPV = 5	LOS: 1 to 100 BPV: 1 to 100 000
Alarm Elevation Time	86 400 s	60 to 500 000 s, 0 = disabled
Port Status	Enabled	Enabled Disabled
Port Name	None (blank)	Any string from 0 – 20 characters

Chapter 8 Output Module Reference Data

This chapter contains reference information for the Output modules available for use in the SSU-2000e.

In This Chapter

- [E1 Output Module](#)
- [DS1 Output Module](#)
- [Composite Clock Output Module](#)
- [E1/2048 kHz Output Module](#)
- [2048 kHz Output Module](#)
- [RS-422 Output Module](#)
- [Buffer Module](#)

E1 Output Module

This section provides user-reference data for the E1 Output module (part number 23413018-000-0) that is used in both the SSU-2000e main chassis and in the optional SDU-2000e expansion shelf.

Functional Overview

The E1 Output module uses one of three 4 kHz clocks from the SSU-2000e main chassis backplane to generate a phase-locked signal of 2.048 Mbps. If the unit is inserted into an SDU-2000e expansion shelf, a fourth 4 kHz clock (D-clock) is available. The phase-locked 2.048 Mbps signal is used to generate a set of 20 output signals for distribution to large networks.

In addition, the phase-locked 2.048 Mbps signal is used to clock the frame generator (or framer) for insertion of proper framing bits.

The output SSM can be automatically set by the input signal or manually using an ICS or TL1 command. See the *SSU-2000e Technical Reference* for details on setting the output SSM.

A microcontroller unit on the E1 Output module communicates with other boards in the main shelf and performs Output module configuration. The module's memory subsystem (EEPROM, RAM and serial EEPROM) stores the executable image, the PLD image and other configuration and temporary information for an on-module microprocessor.

The E1 Output modules can be used individually or configured for operation as redundant pairs in the shelf.

Functional Block Diagram

A simplified block diagram of the E1 Output module is shown in Figure 8-1.

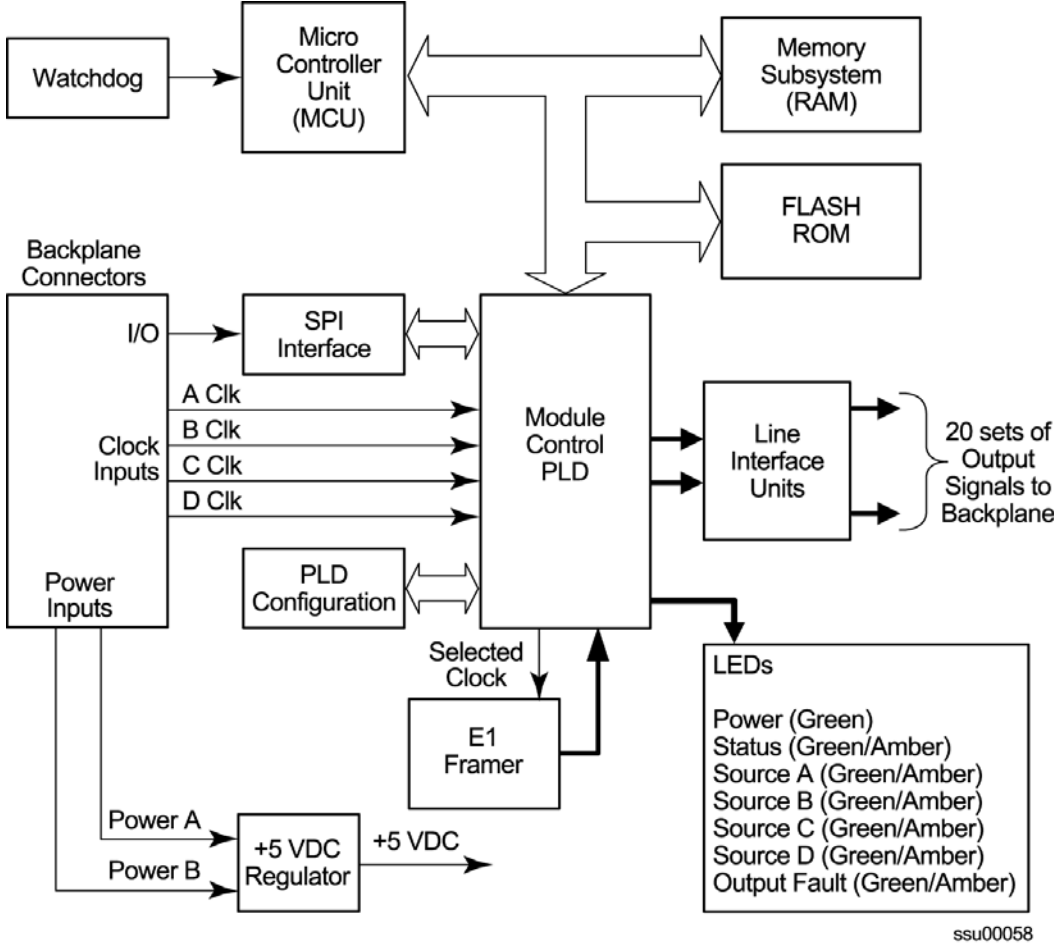
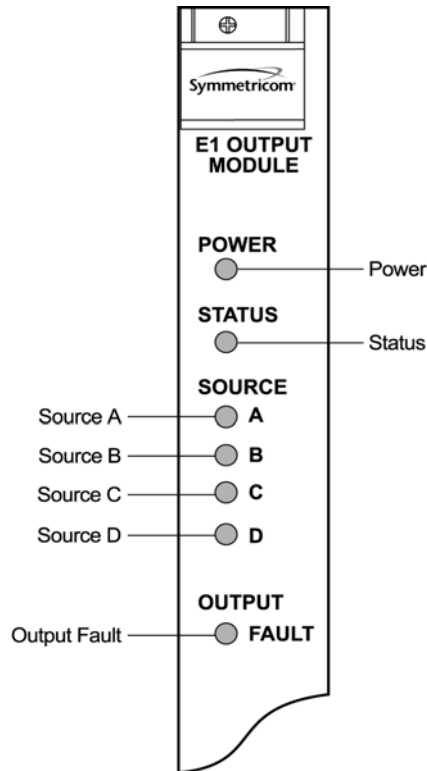

Figure 8-1. Block Diagram of the E1 Output Module

Status LED Indicators

The E1 Output module has seven status LED indicators along the front edge of the module that are used for visually conveying status information to the user. The LEDs are shown in [Figure 8-2](#) and described in [Table 8-1](#).



ssu00033

Figure 8-2. Front Panel of the E1 Output Module

Table 8-1. E1 Output Module Status LED Indicators

Indicator	Color	Description
POWER	Green	On = +5 VDC power available on the Output module Off = +5 VDC not present on the module
STATUS	Green/Amber	On (Green) = Module functioning correctly Blinking Amber = Output module is downloading firmware On (Amber) = Output module failure
SOURCE A	Green/Amber	On (Green) = Clock A is the selected source clock On (Amber) = Faulty or missing A source clock Off = Source A is ignored or good and not selected
SOURCE B	Green/Amber	On (Green) = Clock B is the selected source clock On (Amber) = Faulty or missing B source clock Off = Source B is ignored or good and not selected

Table 8-1. E1 Output Module Status LED Indicators (Continued)

Indicator	Color	Description
SOURCE C	Green/Amber	On (Green) = The Bypass clock (Clock C) is the selected source clock. See Bypass Clock (Clock C) , on page 27 On (Amber) = Faulty or missing source C clock Off = Source C is ignored or good and not selected
SOURCE D	Green/Amber	On (Green) = The Expansion clock (Clock D) is the selected source clock. The module is in an Expansion shelf On (Amber) = Faulty or missing source D clock Off = Source D is ignored or good and not selected
OUTPUT FAULT	Amber	On = Module has detected one or more faulty outputs Off = All output signals are good

Performance Specifications

The E1 Output module performance specifications are provided in [Table 8-2](#).

Table 8-2. E1 Output Module Performance Specifications

Performance Characteristic	Specification
Signal	Alternate Mark Inversion (AMI)
Waveshape	Per ITU-T CC (10/98)
Risetime	<100 ns
Pulse Width	244 ns, nominal into 120Ω
Pulse Interval	488 ns, nominal
Duty Cycle	50%
Pulse Amplitude	2.2 to 3.3 Vpp
Jitter	< 0.01 UI
Number of Outputs	20

DS1 Output Module

This section provides user-reference data for the DS1 Output module (part number 23413017-000-0) used in both the SSU-2000e main chassis and in the optional SDU-2000e Expansion shelf.

Functional Overview

The DS1 Output module generates a phase-locked signal of 1.544 Mbps using one of three 4 kHz clocks from the backplane of the SSU-2000e main shelf (A, B, and C clocks). If the module is inserted into the SDU-2000e Synchronization Distribution Unit (expansion shelf), a fourth 4 kHz clock (D clock) is available. The phase-locked signal generates a set of 20 output signals for distribution to large networks. In addition, the signal clocks the frame generator (or framer) for insertion of proper framing bits. A simplified block diagram of the DS1 Output module is shown in [Figure 8-3](#).

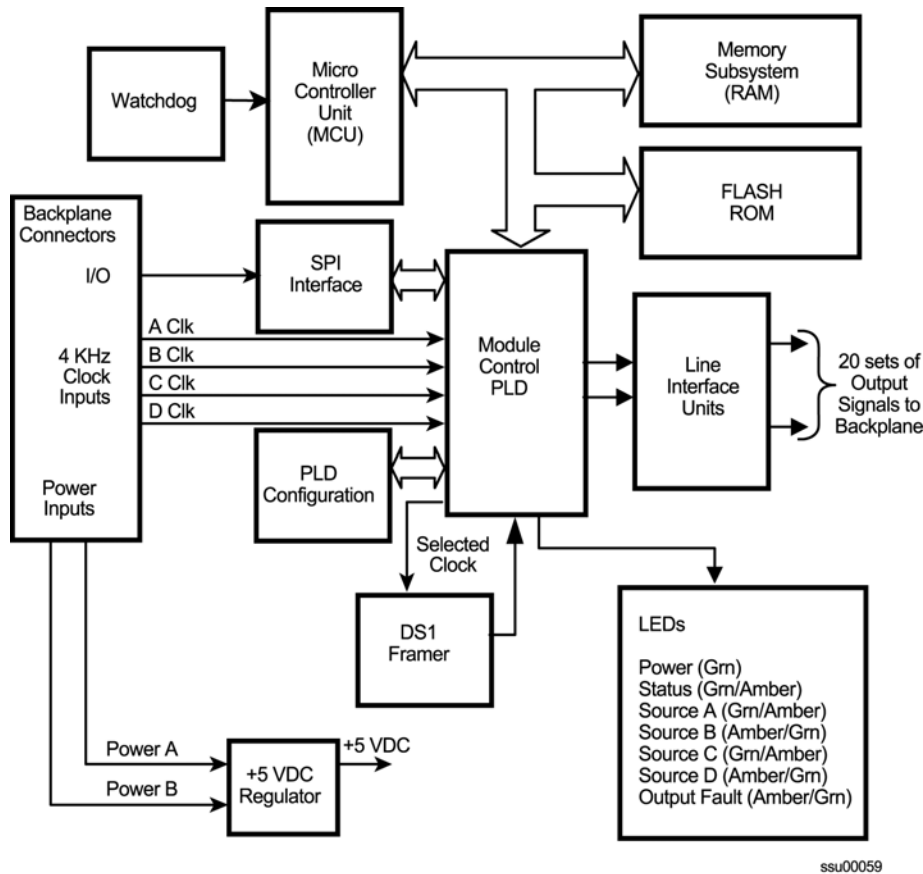

Figure 8-3. Block Diagram of the DS1 Output Module

The output SSM can be automatically set by the input signal or manually using an ICS or TL1 command. See the *SSU-2000e Technical Reference* for details on setting the output SSM.

A microcontroller unit on the DS1 Output module communicates with other boards in the main shelf and performs Output module configuration. The module's memory subsystem (EEPROM, RAM and serial EEPROM) stores the executable image, the PLD image and other configuration and temporary information for an on-module microprocessor.

The DS1 Output modules may be used individually or configured for operation as redundant pairs in the shelf.

Status LED Indicators

The DS1 Output module status LED indicators are shown in [Figure 8-4](#) and are described in [Table 8-3](#).

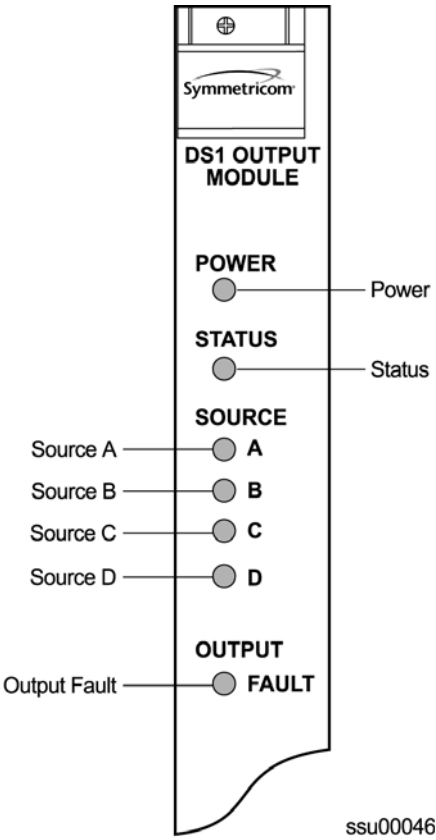

Figure 8-4. Front Panel of the DS1 Output Module

Table 8-3. DS1 Output Module Status LED Indicators

Indicator	Color	Description
POWER	Green	On = +5 VDC power available on the Output module Off = +5 VDC not present on the module
STATUS	Green/Amber	On (Green) = Module functioning correctly Blinking Amber = Output module is downloading firmware On (Amber) = Output module failure
SOURCE A	Green/Amber	On (Green) = Clock A in slot 1 is the selected source clock On (Amber) = Faulty or missing Clock A Off = Clock A is good and not selected
SOURCE B	Green/Amber	On (Green) = Clock B in slot 12 is the selected source clock On (Amber) = Faulty or missing Clock B Off = Clock B is good and not selected
SOURCE C	Green/Amber	On (Green) = The Bypass clock (Clock C) is the selected source clock. See Bypass Clock (Clock C) , on page 27 On (Amber) = Faulty or missing Bypass clock Off = Bypass clock is ignored, or good and not selected
SOURCE D	Green/Amber	On (Green) = The Expansion clock (Clock D) is the selected source clock. The module is in an Expansion shelf On (Amber) = Faulty or missing Expansion clock Off = Expansion clock is ignored, or good and not selected
OUTPUT FAULT	Amber	On = Module has detected one or more faulty outputs Off = All output signals are good

Performance Specifications

The DS1 Output module specifications are provided in [Table 8-4](#).

Table 8-4. DS1 Output Module Performance Specifications

Performance Characteristic	Specification
Signal	Alternate Mark Inversion (AMI)
Waveshape	Per ITU Rec. G.703 and ANSI T1.102
Risetime	<100 ns
Pulse Width	324 ns, nominal into 100Ω
Pulse Interval	648 ns, nominal
Duty Cycle	50%
Pulse Amplitude	2.6 to 3.6 Vpp
Jitter	< 0.01 UI
Number of Outputs	20

Composite Clock Output Module

This section provides user-reference data for the Composite Clock Output module (part number 23413279-000-0) used in both the SSU-2000e main chassis and in the optional SDU-2000e expansion shelf.

Composite Clock Output Module Overview

The Composite Clock Output module generates 20 signal pairs (TTIP and TRING signal pairs). Each output is a transformer-coupled symmetrical pair. Each output pair can be turned off independently of other channels; relays on each output allow for disconnecting the driver output from the output pins. These outputs are independently configurable for duty cycle (50/50 or 62.5/37.5) and phase delay from 0 to 3.4 μ sec in 8 or more steps. Refer to [Changing Factory Defaults](#), on page 114, for more information on duty cycle settings.

The outputs are byte and polarity phase aligned with the selected 4 kHz clock. Each output signal is monitored for a failed output on an independent basis. An output is said to be failed when either the polarity pulse falls below 2.1 volts base to peak, when polarity reversal can no longer be detected, or when return to zero cannot be detected.

The outputs of the Composite Clock Output module meet the criteria set forth in Bellcore GR-378-CORE and TR-TSY-000458 for signal type, amplitude, and waveshape. ITU-T Rec. G.703 Centralized Clock is partially supported (50/50 duty cycle) except only the Bellcore signal levels are generated.



Note: External, customer-supplied padding can be affixed to attenuate the output level to meet Composite Clock specifications.

Functional Block Diagram

A simplified block diagram of the Composite Clock Output module is shown in [Figure 8-5](#).

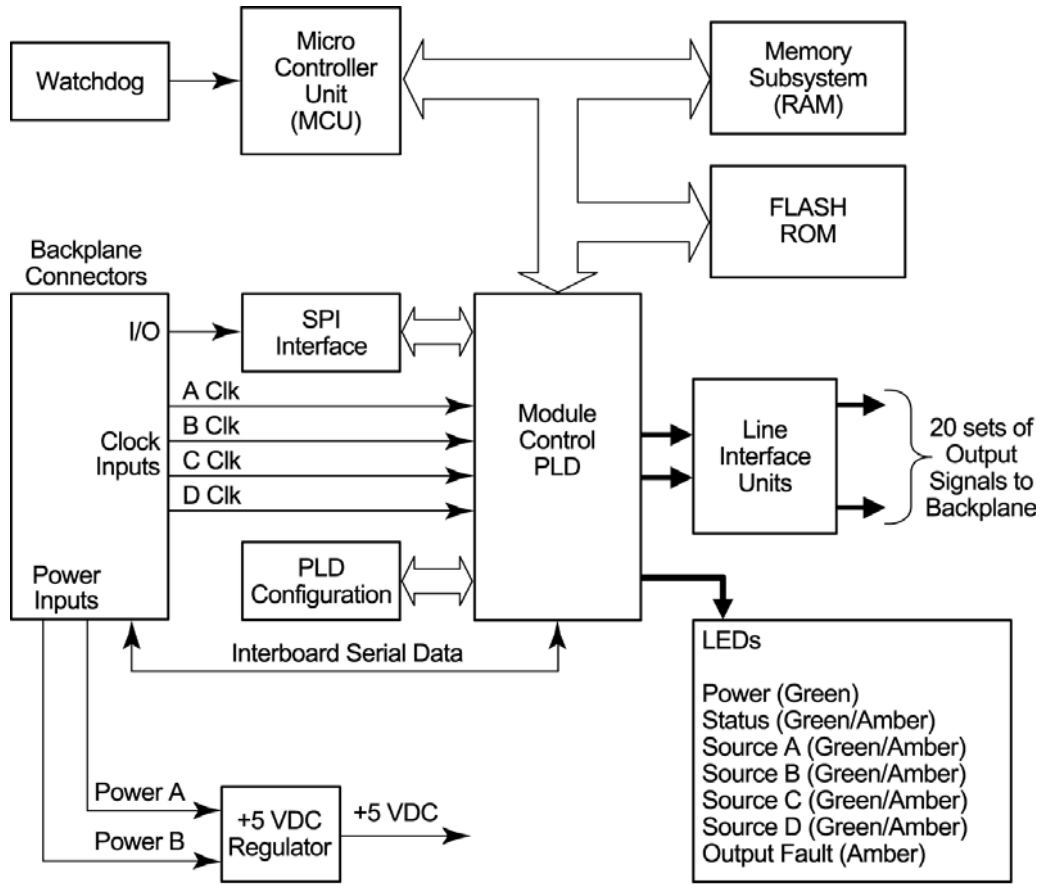

ssu00057

Figure 8-5. Block Diagram of the Composite Clock Output Module

Status LED Indicators

The Composite Clock Output module status LED indicators are shown in [Figure 8-6](#) and described in [Table 8-5](#).

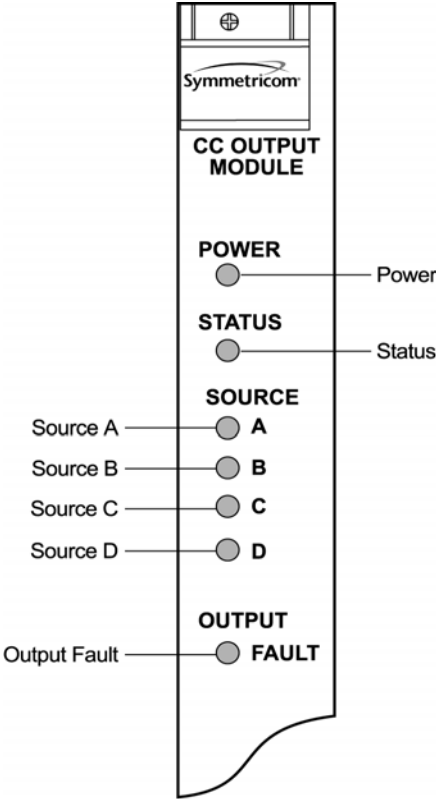

ssu00047

Figure 8-6. Front Panel of the Composite Clock Output Module

Table 8-5. Composite Clock Output Module Status LED Indicators

Indicator	Color	Description
POWER	Green	On = +5 VDC power available on the Output module Off = +5 VDC not present on the module
STATUS	Green/Amber	On (Green) = Module functioning correctly Blinking Amber = Output module is downloading firmware On (Amber) = Output module failure
SOURCE A	Green/Amber	On (Green) = Clock A is the selected source clock On (Amber) = Faulty or missing A source clock Off = Clock A is ignored or good and not selected
SOURCE B	Green/Amber	On (Green) = Clock B is the selected source clock On (Amber) = Faulty or missing B source clock Off = Clock B is ignored or good and not selected

Table 8-5. Composite Clock Output Module Status LED Indicators (Continued)

Indicator	Color	Description
SOURCE C	Green/Amber	On (Green) = The Bypass clock (Clock C) is the selected source clock. See Bypass Clock (Clock C) , on page 27 On (Amber) = Faulty or missing source C clock Off = Clock C is ignored or good and not selected
SOURCE D	Green/Amber	On (Green) = The Expansion clock (Clock D) is the selected source clock. The module is in an Expansion shelf On (Amber) = Faulty or missing source D clock Off = Clock D is ignored or good and not selected
OUTPUT FAULT	Amber	On = Module has detected one or more faulty outputs Off = All output signals are good

Performance Specifications

The performance specifications for the Composite Clock output module are provided in [Table 8-6](#).

Table 8-6. Composite Clock Output Module Performance Specifications

Performance Characteristic	Specification
Signal	Bipolar, Return to Zero, Alternate Mark Inversion (AMI)
Waveshape	Per Bellcore GR-378-CORE Table 6-2 & Figure 6-1
Rise/Fall time	<500 ns
Pulse Width	9.8 μ s \pm 2% for 62.5/37.5 duty cycle 7.8 μ s \pm 2% for 50/50 duty cycle
Pulse Interval	15.6 μ s, nominal
Duty Cycle	62.5/37.5 or 50/50 selectable
Pulse Amplitude	2.7 to 5.5 Vpk, 3.5 Vpk nominal into 133 Ω
Number of Outputs	20 Independent Channels

E1/2048 kHz Output Module

This section provides operating instructions and software provisioning procedures for the Symmetricom E1/2048 kHz Output module (part number 23413292-000-0) designed for use in the SSU-2000e Synchronization Supply Unit.

Functional Overview

The E1/2048 kHz Output module generates 20 outputs that are software-selectable for either E1 or 2048 kHz output signals. Each output port can be turned off independently of other ports; relays on each port disconnect the driver output from the output pins. A squelch feature turns off selected ports when the system PQL falls below predetermined quality levels.

The E1 signal has a multiframe format, with selectable Channel Associated Signaling (CAS) or Common Channel Signalling (CCS); CRC4 can be turned on or off. These default settings do not affect functionality. The Synchronization Status Message (SSM) can be turned on or off, and the bit position can be set to 4, 5, 6, 7, or 8 of time slot 0 of the odd frames. Zero suppression can be turned on or off as required. When zero suppression is off, the signal has Alternate Mark Inversion (AMI) encoding. When zero suppression is on, HDB3 encoding is used.

The output SSM can be automatically set by the input signal or manually using an ICS or TL1 command. See the *SSU-2000e Technical Reference* for details on setting the output SSM.

Provisioning the Signal Type

You use software commands to set the signal type on each port of the E1/2048 kHz Output module. To view or provision the output frequency using ICS commands, see the *SSU-2000e Technical Reference*.

To view the output frequency setting, use the TL1 command `RTRV-PRMTR-OUTE12048`, described in the *SSU-2000e Technical Reference*. To provision the output parameters, use the TL1 command `SET-PRMTR-OUTE12048`, described in the *SSU-2000e Technical Reference*.

Output Squelching

The E1/2048 kHz Output module allows you to selectively turn off (squelch) the outputs during periods of degraded performance.

This feature allows you to turn off any of the 20 output ports on redundant or non-redundant modules. The SSU-2000e uses the system Priority Quality Level (PQL) to determine when the system is operating within specified limits; if the outputs become degraded, the system automatically turns off the assigned ports.

To enable the squelching feature, you must provision a “threshold” PQL value using the OUTPUT command (for ICS mode) or the SET-PRMTR-OUTE12048 command (for TL1 mode). The syntax for each command is shown below. A threshold PQL value of zero disables the squelch function. Threshold PQL values above zero enable the squelch function; when the system PQL is greater than the threshold PQL, the output is squelched.

For example, you can provision output ports 1 through 5 for a threshold PQL of 3 and you can disable squelching for ports 6 through 20 (PQL is set to 0). In this example, if the system PQL is 1, 2, or 3, ports 1 through 20 generate outputs. If the system PQL changes to 4 or higher, outputs on ports 1 through 5 are squelched (turned off) and ports 6 through 20 continue to generate outputs. The response from the Output Status command appears as shown in the following example.

```
Copyright 1997-2005, Symmetricom
SSU_2000->out 2A10
2005-09-06T19:43:03Z ID: SSU2000, Name: SSU_2000
Module Name: Output E1/2048
OUT STATUS      Clk Clk Stat      Port Status      1 1 1 1 1 1 1 1 1 1 2
Loc# Type Sta Sel A B C D Redt PQL 1 2 3 4 5 6 7 8 9 0 1 2 3 4 5 6 7 8 9 0
-----
2A10 E12M Ok B / / / / 4 / / / / / / / / / / / / / / / / / / / / / /

OUTPUT SETUP      ----- E1 -----
Loc# Type Bypass ZS SIG CRC SSM BIT
-----
2A10 E12M On On CAS On On 8
Signal:
P[ 1]= E1, P[ 2]= E1, P[ 3]= E1, P[ 4]= E1, P[ 5]= E1,
P[ 6]= E1, P[ 7]= E1, P[ 8]= E1, P[ 9]= E1, P[10]= E1,
P[11]= E1, P[12]= E1, P[13]= E1, P[14]= E1, P[15]= E1,
P[16]= E1, P[17]= E1, P[18]= E1, P[19]= E1, P[20]= E1,
Squelch:
P[ 1]= 0, P[ 2]= 0, P[ 3]= 0, P[ 4]= 0, P[ 5]= 0,
P[ 6]= 0, P[ 7]= 0, P[ 8]= 0, P[ 9]= 0, P[10]= 0,
P[11]= 0, P[12]= 0, P[13]= 0, P[14]= 0, P[15]= 0,
P[16]= 0, P[17]= 0, P[18]= 0, P[19]= 0, P[20]= 0,
SSU_2000->
```

When the System PQL transitions to a PQL that crosses the user-defined Output-Squelching PQL threshold, the SSU generates a major alarm. The alarm message for Squelch indicates which port(s) are in alarm due to the PQL threshold being crossed. In the example Alarm message below, Port 20 of the E1/2048 kHz module is in alarm.

```
2002-12-12T10:25:26 2A10 Maj Squelch, Below Prov, 00001
```

A five-digit hexadecimal number (consisting of 20 bits) at the end of the alarm message identifies the affected port(s). Each digit represents four of the 20 ports on the module; the first digit represents ports 1 through 4, the second digit represents ports 5 through 8, and so on, as shown in [Figure 8-7](#).

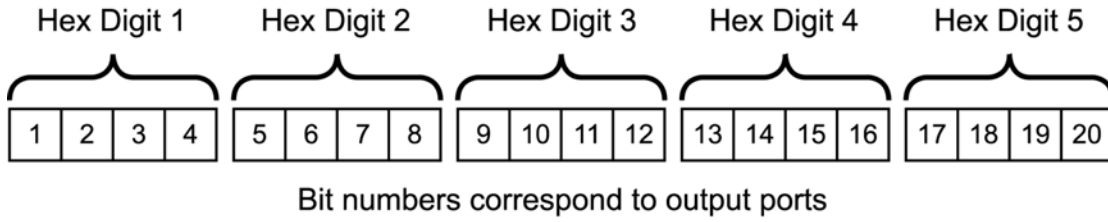

ssu00051b

Figure 8-7. Using the Hex Number to Identify Output Ports

Table 8-7 lists the failed output port number(s) for each possible hex digit. In the above alarm message, the hex number is 00001. To determine the port in alarm, locate the second row (corresponding to Hex Value 1) in Table 8-7. The right-most column has an X, which corresponds to Port 20 (read across from Digit 5).

As another example, if the hex number is A501F, then the following ports are squelched: 1 and 3 (corresponding to the A in Digit 1), 6 and 8 (corresponding to the 5 in Digit 2), 16 (corresponding to the 1 in Digit 4), and 17 through 20 (corresponding to the F in Digit 5).

Table 8-7. Identifying Failed Ports from the Hex Digit

Hex Value	Port	Port	Port	Port
Digit 1	1	2	3	4
Digit 2	5	6	7	8
Digit 3	9	10	11	12
Digit 4	13	14	15	16
Digit 5	17	18	19	20
0	–	–	–	–
1	–	–	–	X
2	–	–	X	–
3	–	–	X	X
4	–	X	–	–
5	–	X	–	X
6	–	X	X	–
7	–	X	X	X
8	X	–	–	–
9	X	–	–	X
A	X	–	X	–
B	X	–	X	X
C	X	X	–	–

Table 8-7. Identifying Failed Ports from the Hex Digit (Continued)

Hex Value	Port	Port	Port	Port
Digit 1	1	2	3	4
Digit 2	5	6	7	8
Digit 3	9	10	11	12
Digit 4	13	14	15	16
Digit 5	17	18	19	20
D	X	X	–	X
E	X	X	X	–
F	X	X	X	X

Use the Alarm command to display the alarm information for a given module; the display includes all E1/2048 kHz Output module alarms, including Alarm #10, Squelching. Use the ALARM command or the SET-PRMTR-OUTE12048 command (described in the *SSU-2000e Technical Reference*) to provision these alarms to Ignore, Report Only, Minor Alarm, Major Alarm (default), or a Critical Alarm.

```
SSU->a1 2a10
2002-07-04T10:25:31 ID: SSU2000 Name: SSU
```

```
Output # Alarm Status Level(*=Elev) Ports
-----
1A06 (00) Hdw Config Ok Major
1A06 (01) Configuration Ok Major
1A06 (02) Clk-A Ok Major
1A06 (03) Clk-B Ok Major
1A06 (04) Clk-C Ok Major
1A06 (05) Clk-D Ok Major
1A06 (06) Clk Selected Ok Major
1A06 (07) VCXO Ok Major
1A06 (08) PLL Ok Major
1A06 (09) Sync Ok Major
1A06 (10) Squelch Ok Major
1A06 (11) PortFlt Ok Major
SSU->
```

Provisioning the Squelch Parameter

To view or provision the squelch using ICS or TL1 commands, see the *SSU-2000e Technical Reference*.

Bypass Clock (CLK-C) Alarms

The SSU-2000e has many configuration options. In order for the system to generate the CLK-C used by the E1/2048 kHz Output module, you must install one of the following Input modules and connect an input signal to the module: DS1, E1, or CC.

If the SSU-2000e has only GPS Input module(s), then set the Bypass mode to OFF to prevent the Output modules from generating the CLK-C alarm (alarm 4).

Output Fault Handling

When an output fault occurs, a port fault alarm occurs. Fault recovery is automatic; when the fault is no longer present, normal operation continues. To prevent “bouncing,” or reporting errors continuously, the module increments an error counter each time a port fault occurs. If the error count exceeds a preset threshold, then the faulty port is disabled. You must disable and then enable the port using software commands to return it to normal service. The error counter automatically resets when there are no errors in 24 hours.

The port status message indicates the state of each port. The letter code for each port is as follows:

- F – port fault
- N – port is disabled
- blank – port is in normal service

The following example shows port 5 with an internal port fault, port 7 with an external port fault, and ports 10, 11, and 12 disabled.

```
SSU+>out
OUT STATUS Clk Clk Stat          Port Status          1 1 1 1 1 1 1 1 1 2
Loc# Type Sta Sel  A B C D    Redt PQL  1 2 3 4 5 6 7 8 9 0 1 2 3 4 5 6 7 8 9 0
-----
1A06 E12M Ok  A    / / /N/N          4    / / / / /I/ /E/ / /N/N/N/ / / / / / / /
```

Functional Block Diagram

A simplified block diagram of the E1/2048 kHz Output module is shown in [Figure 8-8](#).

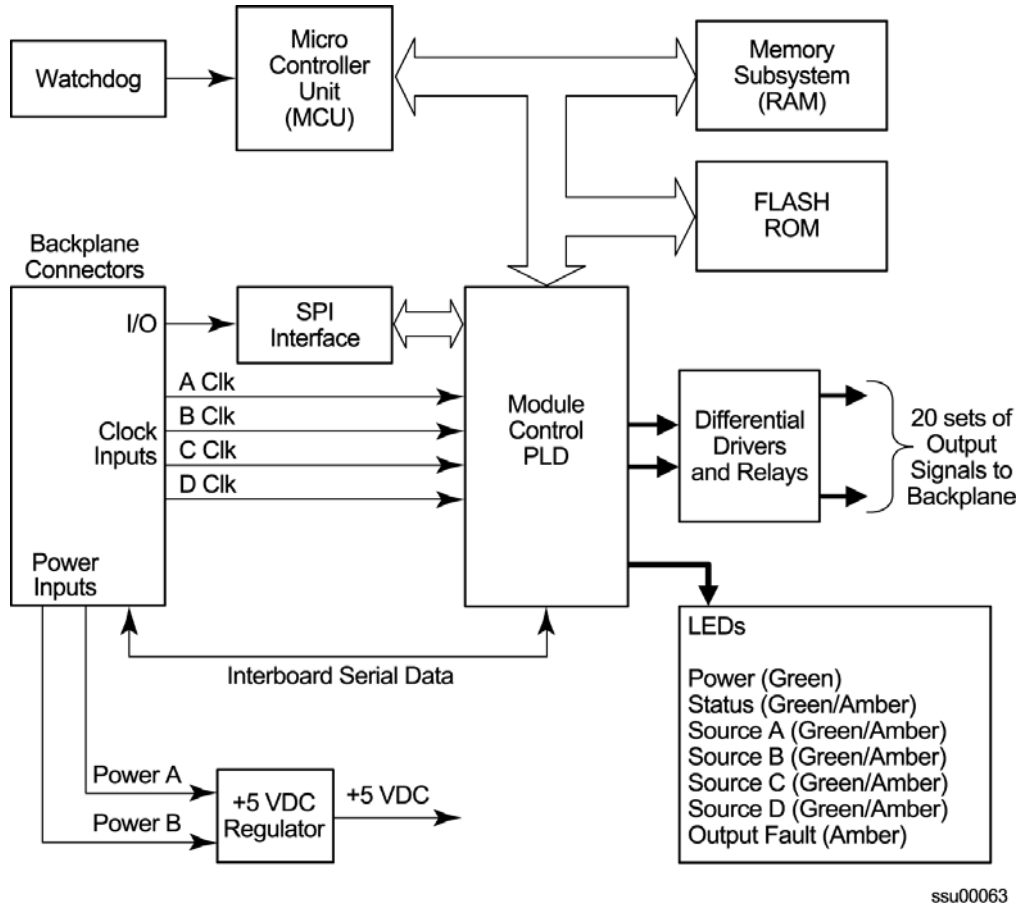

Figure 8-8. Block Diagram of the E1/2048 kHz Output Module

Status LED Indicators

The E1/2048 module has seven status indicators along the front edge of the module that are used for visually conveying status information to the user. The LEDs are shown in [Figure 8-12](#) and described in [Table 8-8](#).

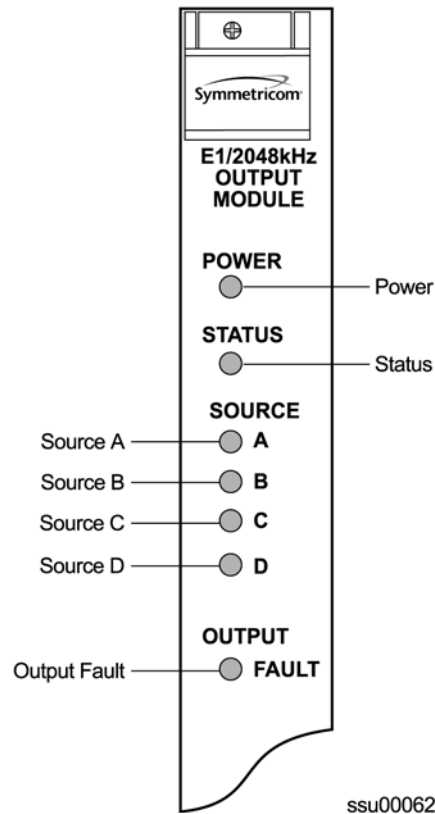

Figure 8-9. Front Panel of the E1/2048 kHz Output Module

Table 8-8. E1/2048 kHz Output Module Status LED Indicators

Indicator	Color	Description
POWER	Green	On = +5 VDC power available on the Output module Off = +5 VDC not present on the module
STATUS	Green/Amber	On (Green) = Output module functioning correctly Blinking Amber = Output module is downloading firmware or the module is disabled On (Amber) = Output module failure
SOURCE A	Green/Amber	On (Green) = Clock A is the selected source clock On (Amber) = Faulty or missing A source clock Off = Clock A is good and not selected
SOURCE B	Green/Amber	On (Green) = Clock B is the selected source clock On (Amber) = Faulty or missing B source clock Off = Clock B is good and not selected

Table 8-8. E1/2048 kHz Output Module Status LED Indicators (Continued)

Indicator	Color	Description
SOURCE C	Green/Amber	On (Green) = The Bypass clock (Clock C) is the selected source clock. See Bypass Clock (Clock C) , on page 27 On (Amber) = Faulty or missing source C clock Off = Clock C is ignored or good and not selected
SOURCE D	Green/Amber	On (Green) = The Expansion clock (Clock D) is the selected source clock. The module is in an Expansion shelf On (Amber) = Faulty or missing source D clock Off = Clock D is ignored or good and not selected
OUTPUT FAULT	Amber	On = Module has detected one or more faulty outputs Off = All output signals are good

Performance Specifications

The specifications for the E1/2048 kHz Output signals are provided in [Table 8-9](#).

Table 8-9. E1/2048 kHz Output Module Specifications

Signal	120 Ω	75 Ω
E1		
Specification	ITU-T G.703/9 (10/98)	ITU-T G.703/9 (10/98)
Signal	AMI or HDB3	AMI or HDB3
Format	CAS or CCS	CAS or CCS
CRC	On or Off	On or Off
SSM	On or Off	ON or Off
Cable	Twisted pair, 120 Ω	Coaxial, 75 Ω
Maximum Peak Voltage	3.3 V	2.61 V
Minimum Peak Voltage	2.7 V	2.13 V
2048 kHz		
Specification	ITU-T G.703/9 (10/98)	ITU-T G.703/9 (10/98)
Signal	Clock	Clock
Format	None	None
Cable	Twisted pair, 120 Ω	Coaxial, 75 Ω
Maximum Peak Voltage	1.90 V	1.50 V
Minimum Peak Voltage	1.00V	0.75 V

2048 kHz Output Module

This section provides operating instructions and software provisioning procedures for the 2048 kHz Output module (part number 23413159-000-0). It also contains default provisioning settings, and procedures for connecting to the SSU-2000e in order to enable, provision, and disable the module.

Functional Overview

The 2048 kHz Output module receives a set of three (four if installed in an expansion shelf) 4 kHz clocks from the Clock modules and uses these clocks to develop an 8.192 MHz phase-locked signal. This phase-locked signal is then used to generate 20 sets of 2048 kHz clock outputs.

The 20 sets of 2048 kHz signal pairs TTIP and TRING represent a transformer-coupled symmetrical pair. Each output can be turned on/off independently of other channels; relays on each output allow for disconnecting the driver output from the output pins. Each output signal is monitored for a failed output on an independent basis. An output signal is designated failed when the level falls below 0.75 volts base to peak.

In non-redundant configuration a failed output will not be turned off, as some equipment may tolerate a wide range of level and still be operating. In redundant operation a failed output will be turned off in one module at a time to try and isolate the source of the problem. The outputs meet the criteria set forth in ITU-T G.703 for signal type, amplitude, and waveshape.

Output Squelching

A new feature, available with Revision C of the firmware for the 2048 kHz Output module, allows you to selectively turn off (squelch) the outputs during periods of degraded performance. To use this feature, the Communications module must have Revision D or later firmware.

This feature allows you to turn off any of 20 output ports on redundant or non-redundant modules. The SSU-2000e uses the system Priority Quality Level (PQL) to determine when the system is operating within specified limits; if the outputs become degraded, then the system automatically turns off the affected ports.

To enable the squelching feature, you must provision a “threshold” PQL value using the OUTPUT command (for ICS mode) or the SET-PRMTR-CLKOUT command (for TL1 mode). The syntax for each command is shown below. A threshold PQL value of zero disables the squelch function. Threshold PQL values above zero enable the squelch function; when the system PQL is greater than the threshold PQL, the output is squelched.

For example, you can provision output ports 1 through 5 for a threshold PQL of 3 and you can disable squelching for ports 6 through 20 (PQL is set to 0). In this example, if the system PQL is 1, 2, or 3, then ports 1 through 20 generate 2048 kHz outputs. If the system PQL changes to 4 or higher, then outputs on ports 1 through 5 are squelched (disabled) and ports 6 through 20 continue to generate 2048 kHz outputs. The response from the Output Status command appears as shown below:

```
SSU->out 2a10
2002-12-03T15:30:14 ID: SSU2000 Name:SSU
Module Name: Output 2048 kHz
OUT STATUS      Clk Clk Stat          Port Status      1 1 1 1 1 1 1 1 1 1 2
Loc# Type Sta Sel      A B C D Redt Pql   1 2 3 4 5 6 7 8 9 0 1 2 3 4 5 6 7 8 9 0
-----
2A10  2048  Ok  A    /Y/Y/N/Y          4    /S/S/S/S/S/ / / / / / / / / / / / / / / / /

OUTPUT SETUP
Loc# Type ZS      MinClk Bypass
-----
2A10 2048 NA      ACQ     Off
Output fault action: Leave On
Squelch Level:
P[ 1]= 3, P[ 2]= 3, P[ 3]= 3, P[ 4]= 3, P[ 5]= 3,
P[ 6]= 0, P[ 7]= 0, P[ 8]= 0, P[ 9]= 0, P[10]= 0,
P[11]= 0, P[12]= 0, P[13]= 0, P[14]= 0, P[15]= 0,
P[16]= 0, P[17]= 0, P[18]= 0, P[19]= 0, P[20]= 0,
```

When the System PQL transitions to a PQL that crosses the user-defined Output-Squelching PQL threshold, the SSU generates an alarm. The alarm message for Alarm #14, Squelch, indicates which port(s) are in alarm due to the PQL threshold being crossed. In the example Alarm message below, Port 20 of the 2048 kHz Output module is in alarm.

```
2002-12-12T10:25:26 2A10 Maj Squelch, Below Prov, 00001
```

A five-digit hexadecimal number (consisting of 20 bits) at the end of the alarm message identifies the affected port(s). Each digit represents four of the 20 ports on the module; the first digit represents ports 1 through 4, the second digit represents ports 5 through 8, and so on, as shown in [Figure 8-10](#).

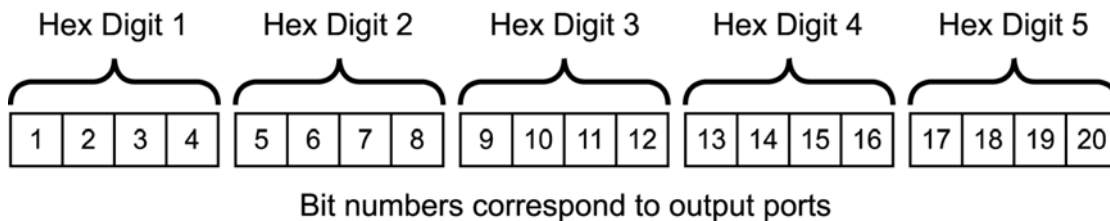

ssu00051b

Figure 8-10. Using the Hex Number to Identify Output Ports

Table 8-10 lists the failed output port number(s) for each possible hex digit. In the above alarm message, the hex number is 00001. To determine the port in alarm, locate the second row (corresponding to Hex Value 1) in **Table 8-10**. The right- most column has an X, which corresponds to Port 20 (read across from Digit 5).

As another example, if the hex number is A501F, then the following ports are squelched: 1 and 3 (corresponding to the A in Digit 1), 6 and 8 (corresponding to the 5 in Digit 2), 16 (corresponding to the 1 in Digit 4), and 17 through 20 (corresponding to the F in Digit 5).

Table 8-10. Identifying Failed Ports from the Hex Digit

Hex Value	Port	Port	Port	Port
Digit 1	1	2	3	4
Digit 2	5	6	7	8
Digit 3	9	10	11	12
Digit 4	13	14	15	16
Digit 5	17	18	19	20
0	–	–	–	–
1	–	–	–	X
2	–	–	X	–
3	–	–	X	X
4	–	X	–	–
5	–	X	–	X
6	–	X	X	–
7	–	X	X	X
8	X	–	–	–
9	X	–	–	X
A	X	–	X	–
B	X	–	X	X
C	X	X	–	–
D	X	X	–	X
E	X	X	X	–
F	X	X	X	X

Use the Alarm command to display the alarm information for a given module to display all 2048 kHz Output module alarms, including Alarm #14, Squelching. Use the Alarm command to provision these alarms to be Ignored or to generate a Report Only, Minor Alarm, Major Alarm (default), or a Critical Alarm.

```
SSU->a1 2a10  
2002-12-12T10:25:31 ID: SSU2000 Name: SSU
```

Output	#	Alarm	Status	Level(*=Elev)	Ports
2A10	(00)	Redundant	Ok	Major	
2A10	(01)	Module Match	Ok	Major	
2A10	(02)	Clk-A	Ok	Major	
2A10	(03)	Clk-B	Ok	Major	
2A10	(04)	Clk-C	Ok	Major	
2A10	(05)	Clk-D	Ok	Major	
2A10	(06)	Clk Level	Ok	Major	
2A10	(07)	Clk Selected	Ok	Major	
2A10	(08)	VCXO	Ok	Major	
2A10	(09)	PLL	Ok	Major	
2A10	(10)	Configuration	Ok	Major	
2A10	(11)	IntPortFlt	Ok	Major	
2A10	(13)	Hdw Config	Ok	Major	
2A10	(14)	Squelch Below Prov		Major	00001

SSU->

Provisioning the Squelch Parameter

To view or provision the squelch using ICS or TL1 commands, see the *SSU-2000e Technical Reference*.

Functional Block Diagram

A simplified block diagram of the 2048 kHz Output module is shown in [Figure 8-11](#).

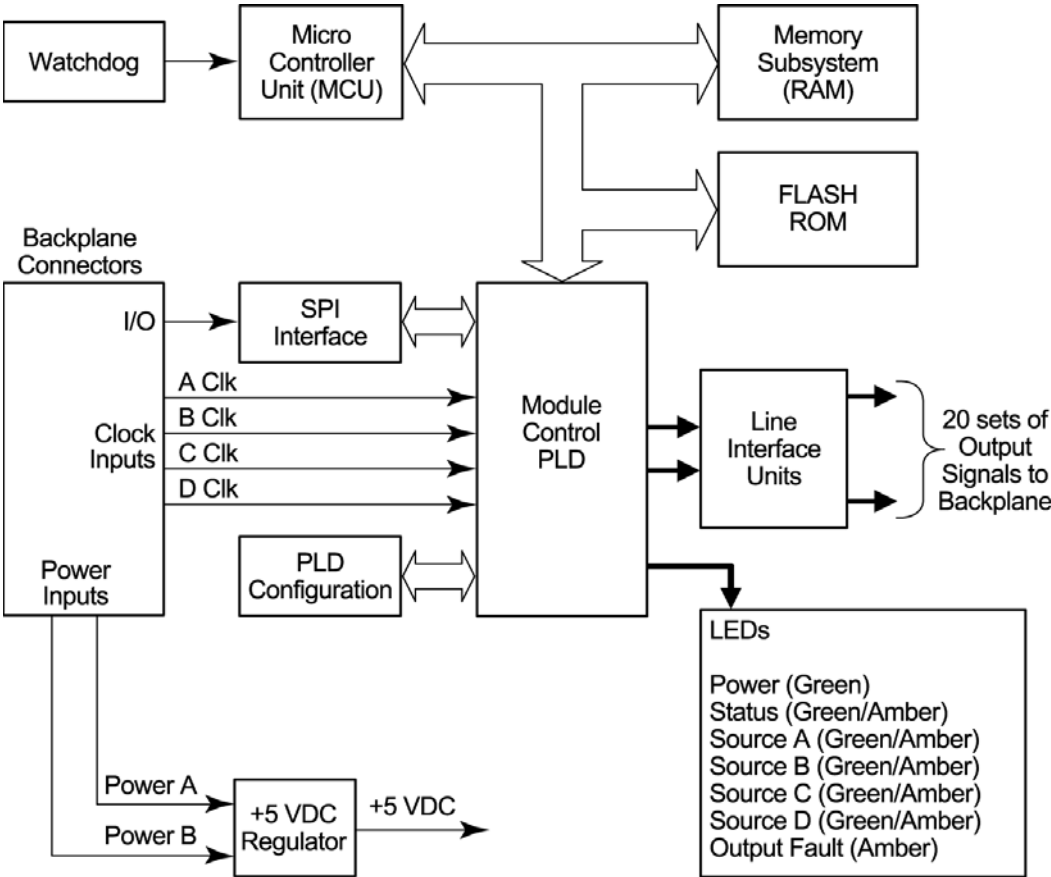

ssu00045

Figure 8-11. Block Diagram of the 2048 kHz Output Module

Status LED Indicators

The 2048 kHz Output module has seven status LED indicators along the front edge of the module that are used for visually conveying status information to the user. The LEDs are shown in [Figure 8-12](#) and described in [Table 8-11](#).

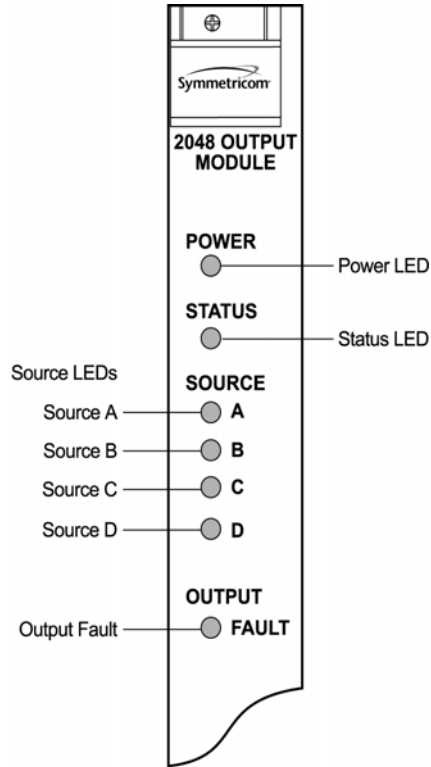

ssu00044

Figure 8-12. Front Panel of the 2048 kHz Output Module

Table 8-11. 2048 kHz Output Module Status LED Indicators

Indicator	Color	Description
POWER	Green	On = +5 VDC power available on the Output module Off = +5 VDC not present on the module
STATUS	Green/Amber	On (Green) = module functioning correctly Blinking Amber = Output module is downloading firmware On (Amber) = Output module failure
SOURCE A	Green/Amber	On (Green) = Clock A is the selected source clock On (Amber) = Faulty or missing A source clock Off = Clock A is ignored or good and not selected
SOURCE B	Green/Amber	On (Green) = Clock B is the selected source clock On (Amber) = Faulty or missing B source clock Off = Clock B is ignored or good and not selected
SOURCE C	Green/Amber	On (Green) = The Bypass clock (Clock C) is the selected source clock. See Bypass Clock (Clock C) , on page 27 On (Amber) = Faulty or missing source C clock Off = Clock C is ignored or good and not selected

Table 8-11. 2048 kHz Output Module Status LED Indicators (Continued)

Indicator	Color	Description
SOURCE D	Green/Amber	On (Green) = The Expansion clock (Clock D) is the selected source clock. The module is in an Expansion shelf On (Amber) = Faulty or missing source D clock Off = Clock D is ignored or good and not selected
OUTPUT FAULT	Amber	On = Module has detected one or more faulty outputs Off = All output signals are good

Performance Specifications

Specifications for the 2048 kHz Output module are provided in [Table 8-12](#).

Table 8-12. 2048 kHz Output Module Specifications

Performance Characteristic	Specification
Frequency	2048 kHz
Waveshape	Per ITU-T CC (Oct. 98) Table 11 and Figure 20
Pulse Amplitude	1.0 to 1.9 Vpk, 1.5 Vpk nominal into 120 Ω 0.75 to 1.5 Vpk, 1.0 Vpk nominal into 75 Ω
Jitter	≤ 0.01 UIpp, 20 Hz to 100 kHz
Number of Outputs	20 Independent

RS-422 Output Module

This section provides operating instructions and software provisioning procedures for the RS-422 Output module (part number 23413287-000-0) designed for use in the SSU-2000e Synchronization Supply Unit.

Functional Overview

The RS-422 Output module generates 10 balanced square-wave outputs (TTIP and TRING signal pairs) and 10 single-ended (Ring) square-wave outputs. Each output can be turned off independently of other ports; relays on each output disconnect the driver output from the output pins. A squelch feature turns off selected ports when the input signal falls below predetermined quality levels.

The user can provision the output port frequency from 8 kHz to 4096 kHz in 8 kHz increments. The frequency selected for port 1 (balanced) is also present on port 11 (single-ended); the frequency selected for port 2 determines the frequency for port 12, and so on.

The RS-422 Output module can be used individually or configured for operation as redundant pairs in the shelf. When redundant modules are installed and the frequency is changed on one module, the redundant module turns its output off, changes to the new frequency locking in phase with it, and then turns its output back on.

Provisioning Output Frequencies

You use software commands to set the frequency of each port on the RS-422 Output module. Commands are available in both ICS and TL-1 modes. To provision the output frequency using ICS or TL1 commands, see the *SSU-2000e Technical Reference*.



Note: You can set frequencies on port 1 through port 10. Port 11 follows the frequency setting of port 1. Port 12 follows the frequency setting of port 2, etc. Ports 1 and 11, 2 and 12, ... 10 and 20 have the same frequency setting.

Output Squelching

The RS-422 Output module allows you to selectively turn off (squelch) the outputs during periods of degraded performance. To use this feature, the Communications module must have Revision D or later firmware.

This feature allows you to turn off any of 20 output ports on redundant or non-redundant modules. The SSU-2000e uses the system Priority Quality Level (PQL) to determine when the system is operating within specified limits; if the outputs become degraded, the system automatically turns off the affected ports.

To enable the squelching feature, you must provision a “threshold” PQL value using the OUTPUT command (for ICS mode) or the SET-PRMTR-CLKOUT command (for TL1 mode). The syntax for each command is shown below. A threshold PQL value of zero disables the squelch function. Threshold PQL values above zero enable the squelch function; when the system PQL is greater than the threshold PQL, the output is squelched.

For example, you can provision output ports 1 through 5 for a threshold PQL of 3 and you can disable squelching for ports 6 through 20 (PQL is set to 0). In this example, if the system PQL is 1, 2, or 3, ports 1 through 20 generate outputs. If the system PQL changes to 4 or higher, outputs on ports 1 through 5 are squelched (disabled) and ports 6 through 20 continue to generate outputs. The response from the Output Status command appears as shown in the following example.

```

SSU+>out 2a10
2003-07-04T15:30:14 ID: SSU2000 Name:SSU
Module Name: Output RS-422
OUT STATUS   Clk Clk Stat      Port Status      1 1 1 1 1 1 1 1 1 1 2
Loc# Type Sta Sel  A B C D Redt Pql 1 2 3 4 5 6 7 8 9 0 1 2 3 4 5 6 7 8 9 0
-----
2A10 ???? Ok  A  /Y/Y/N/Y      4  /S/S/S/S/S/ / / / / / / / / / / / / / / / / /
OUTPUT SETUP
Loc# Type ZS   MinClk Bypass
-----
2A10 ???? NA   ACQ     Off
Output fault action: Leave On
Squelch Level:
P[ 1]= 3, P[ 2]= 3, P[ 3]= 3, P[ 4]= 3, P[ 5]= 3,
P[ 6]= 0, P[ 7]= 0, P[ 8]= 0, P[ 9]= 0, P[10]= 0,
P[11]= 0, P[12]= 0, P[13]= 0, P[14]= 0, P[15]= 0,
P[16]= 0, P[17]= 0, P[18]= 0, P[19]= 0, P[20]= 0,

```

When the System PQL transitions to a PQL that crosses the user-defined Output-Squelching PQL threshold, the SSU generates an alarm. The alarm message for Alarm #14, Squelch, indicates which port(s) are in alarm due to the PQL threshold being crossed. In the example Alarm message below, Port 20 of the RS-422 Output module is in alarm.

```
2002-12-12T10:25:26 2A10 Maj Squelch, Below Prov, 00001
```

A five-digit hexadecimal number (consisting of 20 bits) at the end of the alarm message identifies the affected port(s). Each digit represents four of the 20 ports on the module; the first digit represents ports 1 through 4, the second digit represents ports 5 through 8, and so on, as shown in [Figure 8-13](#).

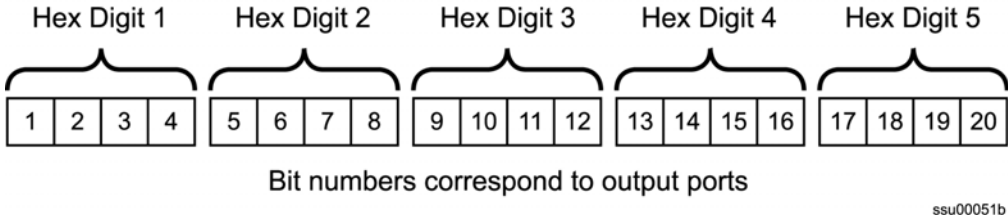

Figure 8-13. Using the Hex Number to Identify Output Ports

[Table 8-13](#) lists the failed output port number(s) for each possible hex digit. In the above alarm message, the hex number is 00001. To determine the port in alarm, locate the second row (corresponding to Hex Value 1) in [Table 8-13](#). The right-most column has an X, which corresponds to Port 20 (read across from Digit 5).

As another example, if the hex number is A501F, then the following ports are squelched: 1 and 3 (corresponding to the A in Digit 1), 6 and 8 (corresponding to the 5 in Digit 2), 16 (corresponding to the 1 in Digit 4), and 17 through 20 (corresponding to the F in Digit 5).

Table 8-13. Identifying Failed Ports from the Hex Digit

Hex Value	Port	Port	Port	Port
Digit 1	1	2	3	4
Digit 2	5	6	7	8
Digit 3	9	10	11	12
Digit 4	13	14	15	16
Digit 5	17	18	19	20
0	–	–	–	–
1	–	–	–	X
2	–	–	X	–
3	–	–	X	X
4	–	X	–	–
5	–	X	–	X
6	–	X	X	–
7	–	X	X	X
8	X	–	–	–
9	X	–	–	X
A	X	–	X	–
B	X	–	X	X
C	X	X	–	–
D	X	X	–	X
E	X	X	X	–
F	X	X	X	X

Use the Alarm command to display the alarm information for a given module; the display includes all RS-422 Output module alarms, including Alarm #14, Squelching. Use the Alarm command to provision these alarms to Ignore, Report Only, Minor Alarm, Major Alarm (default), or a Critical Alarm. Refer to the *SSU-2000e Technical Reference* for more information on using the Alarm command.

```
SSU+>a1 2a10
2002-07-04T10:25:31 ID: SSU2000 Name: SSU
```

Output #	Alarm	Status	Level(*=Elev)	Ports
2A10	(00) Hdw Config	Ok	Major	
2A10	(01) COnfiguration	Ok	Major	
2A10	(02) Clk-A	Ok	Major	
2A10	(03) Clk-B	Ok	Major	

2A10	(04) Clk-C	Ok	Major
2A10	(05) Clk-D	Ok	Major
2A10	(06) Clk Selected	Ok	Major
2A10	(07) VCXO	Ok	Major
2A10	(08) PLL	Ok	Major
2A10	(09) PortFlt Active	Ok	Major
SSU->			

Provisioning the Squelch Parameter

To view or provision the squelch using ICS or TL1 commands, see the *SSU-2000e Technical Reference*.

Functional Block Diagram

A simplified block diagram of the RS-422 Output module is shown in [Figure 8-14](#).

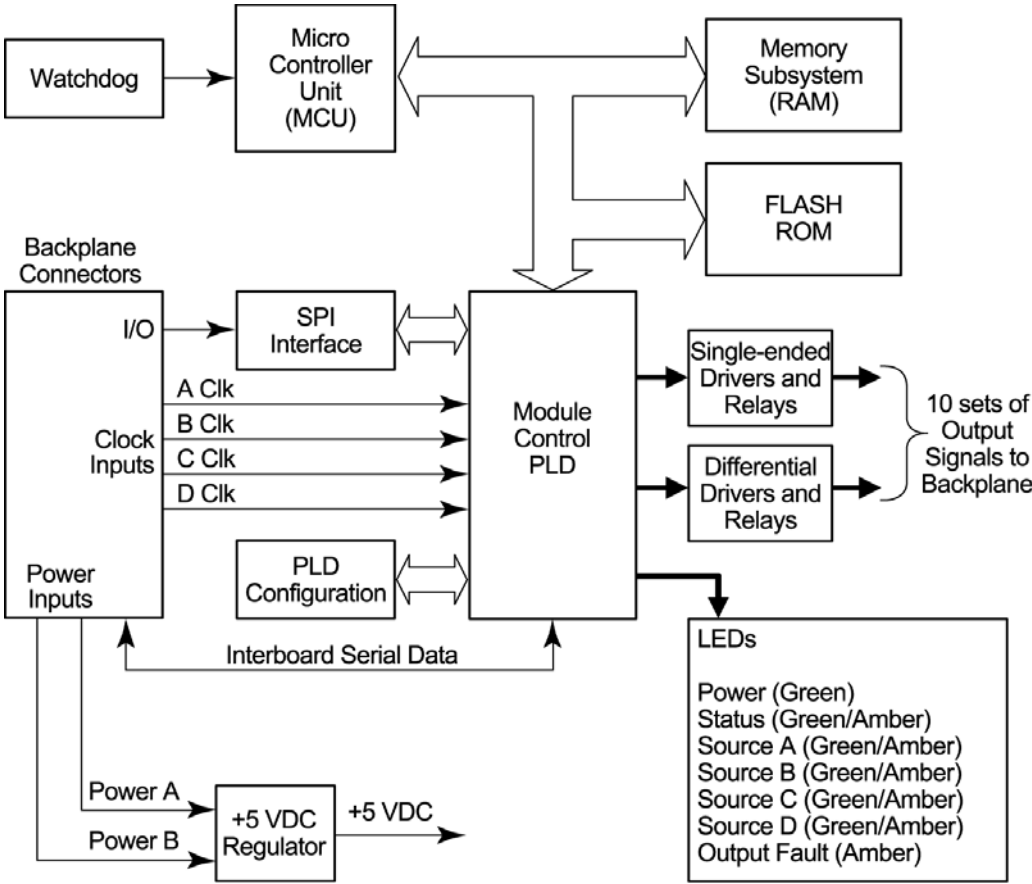

ssu00060

Figure 8-14. Block Diagram of the RS-422 Output Module

Status LED Indicators

The RS-422 Output module has seven LED status indicators along the front edge of the module that are used for visually conveying status information to the user. The LEDs are shown in [Figure 8-15](#) and described in [Table 8-13](#).

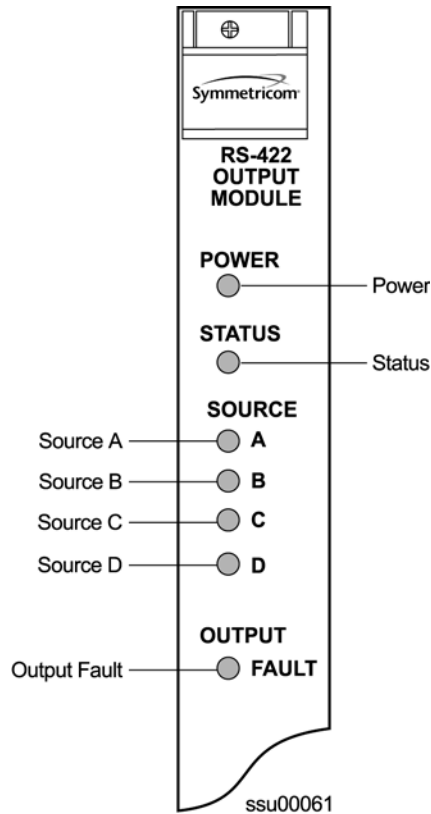

Figure 8-15. Front Panel of the RS-422 Output Module

Table 8-14. RS-422 Output Module Status LED Indicators

Indicator	Color	Description
POWER	Green	On = +5 VDC power available on the Output module Off = +5 VDC not present on the module
STATUS	Green/Amber	On (Green) = Output module functioning correctly Blinking Amber = Output module is downloading firmware On (Amber) = Output module failure
SOURCE A	Green/Amber	On (Green) = Clock A is the selected source clock On (Amber) = Faulty or missing A source clock Off = Clock A is ignored or good and not selected
SOURCE B	Green/Amber	On (Green) = Clock B is the selected source clock On (Amber) = Faulty or missing B source clock Off = Clock B is ignored or good and not selected

Table 8-14. RS-422 Output Module Status LED Indicators (Continued)

Indicator	Color	Description
SOURCE C	Green/Amber	On (Green) = The Bypass clock (Clock C) is the selected source clock. See Bypass Clock (Clock C) , on page 27 On (Amber) = Faulty or missing source C clock Off = Clock C is ignored or good and not selected
SOURCE D	Green/Amber	On (Green) = The Expansion clock (Clock D) is the selected source clock. The module is in an Expansion shelf On (Amber) = Faulty or missing source D clock Off = Clock D is ignored or good and not selected
OUTPUT FAULT	Amber	On = Module has detected one or more faulty outputs Off = All output signals are good

Performance Specifications

Specifications for the RS-422 Output module are provided in [Table 8-11](#).

Table 8-15. RS-422 Output Module Performance Specifications

Performance Characteristic	Specification
Frequency	8 kHz to 4096 kHz, in 8 kHz increments
Format/level	Ports 1–10: Per TIA/EIA-422V Ports 11–20: TTL
Waveshape	Differential square wave, 50/50 duty cycle Single-ended square wave, 50/50 duty cycle
Rise/Fall time	< 50 ns
Jitter	<0.03 UI up to 1.96 MHz
Number of Outputs	10 differential 10 single-ended

Buffer Module

This section describes the Buffer module (part number 23413122-000-0) used in the SDU-2000e Expansion shelf. The Buffer module buffers the backplane and clock signals sent from the main shelf; the modules are installed in slots 15 and 16 of the SDU-2000e. Symmetricom recommends a minimum of one Buffer module in each expansion shelf; a second Buffer module provides redundancy.

Status LED Indicators

The Buffer module indicators (LEDs) are shown in [Figure 8-16](#) and described in [Table 8-15](#).

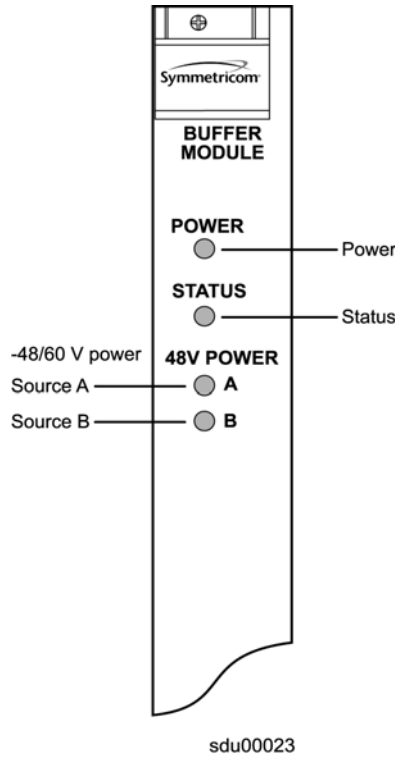

Figure 8-16. Front Panel of the Buffer Module

Table 8-16. Buffer Module Status LED Indicators

Indicator	Color	Description
POWER	Green	On = +5 VDC power available on the Output module Off = +5 VDC not present on the module
STATUS	Green/Amber	On (Green) = Output module functioning correctly On (Amber) = Output module failure
-48V Power A	Green/Amber	On (Green) = Receiving input power from Source A On (Amber) = Power connections reversed Off = Loss of Source A
-48V Power B	Green/Amber	On (Green) = Receiving input power from Source B On (Amber) = Power connections reversed Off = Loss of Source B

Chapter 9 Hardware Configuration Guide

This chapter describes how to configure the SSU-2000e into a variety of telecommunications configurations, depending on which modules are installed.

In This Chapter

- [Configuring a Conventional SSU/TSG System](#)
- [Configuring a Primary Reference Source \(PRS\) System](#)
- [Configuring a Monitor-Only System](#)
- [SSU-2000e Configuration Chart](#)
- [SDU-2000e Configuration Chart](#)

Configuring a Conventional SSU/TSG System

The SSU/TSG configuration allows for input of external references to which the Clock modules are phase locked. This configuration allows for monitoring of several inputs and for synchronization of output signals. [Figure 9-1](#) shows a TSG configuration.

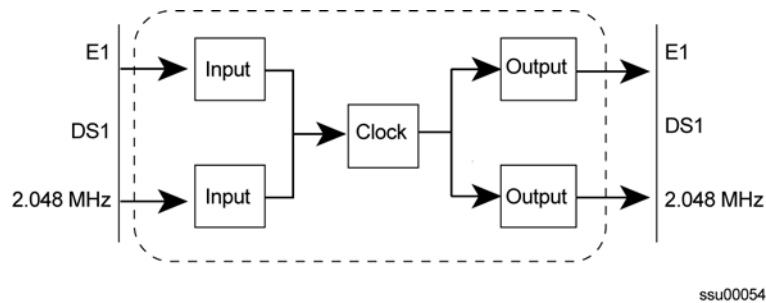

Figure 9-1. Timing Sync Generator (TSG) System Configuration

The TSG configuration consists of the following:

- SSU-2000e main chassis
- Communications module
- Up to three E1/DS1 Input modules
- One or two Clock module(s) (2E/3E)
- Up to three E1 and/or DS1 Output module pairs
- Corresponding number of Output I/O adapter panels and SCSI output cables
- 1.0-inch wide filler panels and a 3-1/2" wide filler panel as necessary

Configuring a Primary Reference Source (PRS) System

In a Primary Reference Source (PRS) configuration, the SSU-2000e meets the specifications defined in American National Standards Institute (ANSI) T1.101-1994. ANSI defines a Primary Reference Source as “equipment that provides a timing signal whose long-term accuracy is maintained at $1 \times 10E^{-11}$ or better, with verification to Universal Coordinated Time (UTC), and whose timing signal is used as the basis of reference for the control of other clocks within a network”. If standard Input modules are installed in the remaining input slots, this configuration also allows for monitoring of other external signals, such as DS1, E1, composite clock, and various clock frequencies. Time-of-day functionality is available via the Ethernet port employing NTP. [Figure 9-2](#) shows a PRS configuration.

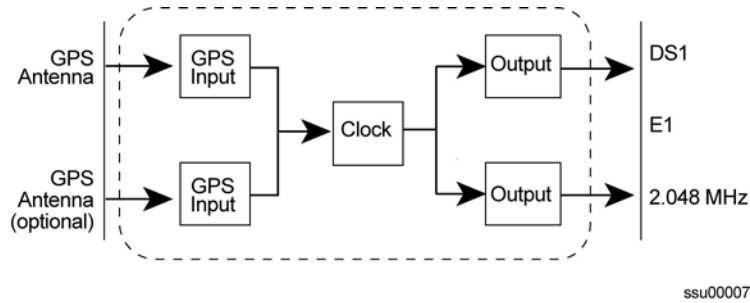

Figure 9-2. SSU-2000e Configured as PRS System

The SSU-2000e PRS configuration consists of the following:

- SSU-2000e main chassis
- Communications Module
- One or two GPS Input Modules
- One Clock Module (2E or 3E)
- Up to three E1 and/or DS1 Output Module pairs
- 1.0-inch wide filler panels and a 3-1/2" wide filler panel as necessary

Configuring a Monitor-Only System

In a monitor-only configuration, no output signals are required. One of the inputs is designated as the reference, and the SSU-2000e Clock module is locked directly to this signal. All remaining input signals are then compared to the phase-locked oscillators (and indirectly to the designated input reference). The SSU-2000e can support up to 27 inputs in this type of configuration. [Figure 9-3](#) shows a monitor-only configuration.

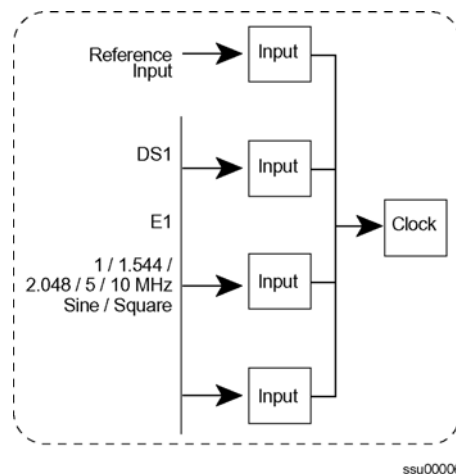

Figure 9-3. SSU-2000e Configured as Monitor-Only System

A monitor-only configuration consists of the following:

- SSU-2000e main chassis with SDU Termination Plug
- Communications Module
- Up to three Input Modules (1-Port or 3-Port DS1 or E1)
- Stratum 2E Clock Module
- Stratum 3E Clock Module
- 1.0-inch wide filler panels and a 3-1/2" wide filler panel as necessary

Configuring a Subtending SSU

The SSU-2000e configured as a Subtending Synchronization Supply Unit (SSU) provides remote phase synchronization and holdover capabilities to telecom network elements, such as digital switches, Digital Access Crossover Systems (DACs), and channel banks for customers with very large equipment offices. For further information on Subtending SSUs, refer to Section 7 of Telcordia Specification GR-378-CORE.

The Subtending SSU configuration is designed in accordance with the Building Integrated Timing Supply (BITS) concept for intraoffice synchronization distribution. The BITS concept provides a synchronization hierarchy that is traceable back to one master clock (SSU), or redundant master clock pairs, referred to as the BITS. The BITS provides DS1 and Composite Clock (CC) timing to all synchronized clocks in the office, which provides timing inputs for all remote (subtending) SSUs.

The Subtending SSU configuration provides Composite Clock (CC) outputs that are frequency-locked and phase-aligned to the CC reference signal. If the CC input signal fails, the Clock module provides holdover.

This section contains an introduction to the hardware and software that is specific to a Subtending SSU configuration.

Functional Description

The SSU-2000e configured as a Subtending SSU broadens the Symmetricom SSU-2000 family of products by providing subtending clock functionality when referenced to a master TSG/BITS equipped with a Stratum 3E or better clock. The following combination of hardware and software configuration meets Subtending SSU criteria described in Section 7 of Telcordia Specification GR-378-CORE.

Hardware – Use the Subtending SSU when there is a need for more timing outputs or longer distribution paths than can be supplied by a single TSG. The Subtending SSU receives redundant Composite Clock (CC) reference signals directly from the Master BITS Clock. The CC signals are used for primary and secondary inputs and the SSU phase-locks to the selected reference to ensure proper DS0 phase alignment throughout the office. If both CC reference inputs fail, the shelf provides Stratum 3E holdover stability. If both 3E Clock modules fail, the Subtending SSU uses the CC reference input for clock bypass operation.

Input Reference Signals – The Subtending SSU configuration requires at least one CC input signal for phase alignment of the CC output signals. The selected CC input provides measured phase information to each Clock module, where it is used to control the clock's frequency and establish the holdover value for the Clock modules. The operator can manually or automatically select the reference. Switching references can occur repeatedly without accumulating phase or frequency error. Restoring the primary reference source can return the unit to tracking the primary signal.

Software – The Subtending SSU software contains a command that allows the user to select between the normal SSU mode and the subtending mode of operation.

A Communications module with Subtending SSU software installed identifies the Input, Output, and Clock modules that are provisioned in the system.

Input Section

The Input section consists of one or more CC Input modules connected to CC signals from a Master BITS shelf. Other input modules (DS1, etc.) may be installed, but in the Subtending mode these inputs are used for monitoring only, and are never selected as reference inputs for phase and frequency control of the outputs.

The CC Input modules make phase measurements between the input signal and the clock oscillator(s). From these phase measurements on the selected input, the Clock modules compute frequency offset correction and holdover value. The selected Input module also generates a 4 kHz “C” clock that is used to align the phase of the CC output signals.

Operating Mode

The operating mode of the SSU is set with the ICS command OPERMODE [NORMAL | SUB]. In Normal mode, the unit operates as specified in [Chapter 1, Product Overview](#). In the Subtending mode, the unit uses only the CC inputs as reference sources. The bipolar violation (BPV) occurrences in the selected input are used to generate a signal output for phase alignment of the CC output signals. In addition, phase measurements on the selected input are used to control the average frequency of the outputs. If there is a significant difference in the BPV alignment between the selected CC input and any secondary CC inputs, the unit

issues a warning that the reference signals are not phase aligned. It is the operator's (or installer's) responsibility to ensure that the CC inputs are from the same (master) BITS and that they are wired correctly to maintain the same polarity. A valid CC input is required when starting the Subtending mode in order to align the phase of the CC outputs.



Note: When provisioning the SSU-2000e to phase align Composite Clock Outputs to Composite Clock Inputs, you can instruct the SSU to transition or change modes of operation (Normal, Subtending). Changing modes of operation is a system "turn-up procedure" and should only be performed when the SSU Composite Clock Outputs are not "in-service". Switching modes of operation is not defined by any Telecom Standard or Requirement; if you instruct the system to change the current mode of operation, you should expect the CC outputs to generate a momentary phase transient.

Selecting Input References and Switching References

In the Subtending mode, the unit selects the highest priority valid CC input available. If the selected input is lost, the unit switches to any alternate CC input as specified by priority assignments; the phase and frequency of the CC outputs follow the new reference signal. If all CC inputs are invalid, the output phase continues at the last valid alignment before the input was lost; the frequency is established by the learned holdover values in the Clock modules. When a valid CC input is re-established, the CC output is immediately aligned to the selected input signal. A CC input is invalid when it is in LOS or it has invalid BPV occurrences. LOS is declared when the Input module is unable to track the expected 64 kHz input; an invalid BPV event occurs when the expected 8000 BPVs per second varies by more than $\pm 10\%$.

Output Section

The output section operates exactly the same in Subtending mode as in Normal mode, except for the CC Output modules. In the Subtending mode, the CC outputs are phase aligned with the selected CC input reference signal. The output section consists of up to 120 channels from six Output modules (60 channels from 3 redundant pairs) that reside in the main shelf and up to 1120 channels from 56 modules (560 channels from 28 redundant pairs) in a fully expanded system with four SDU-2000e expansion shelves. Each Output module type provides 20 independent output synchronization signals.

Output modules are available to support the following formats:

- DS1, SF (D4) and ESF
- E1, CAS, and CCS
- 2048 kHz
- Composite Clock (CC) (64/8 kHz)
- Other typical clock frequencies

Setting Subtending Parameters

The SSU-2000e software includes the following new command that allows you to enable and disable the Subtending mode. For additional information on general syntax and usage, refer to the *SSU-2000e Technical Reference*.

OPERMODE

This command allows you to view and change the operating mode of the SSU-2000e.

Level 0	Not applicable
Level 1	Not applicable
Level 2	Not applicable
Level 3	OPERMODE [SUB NORMAL] OPERMODE SYNC [1 - 10]

If you do not specify a parameter, the system displays the current mode.

SUBTENDING	Sets the SSU to Subtending mode.
NORMAL	Sets the SSU to normal TSG operation.
SYNC	Perform a special operation to sync a reference clock to Clock C.
1-10	Number of steps in NCO offset, each step is 100 ns. The default value is 1 (i.e. 100 ns)

The unit must be in the subtending mode (either ANSI or Japanese) when you enter this command.

Once this command takes effect, the unit enters the SYNC process. During process, don't change selected clock and selected input reference. Typing ^C will interrupt the SYNC process. You will have a choice to stay or leave the SYNC process.

Level 4	Same as Level 3 operation.
Restrictions	See Changing to Subtending SSU Mode , on page 234, for hardware and software requirements.

Changing to Subtending SSU Mode

To change an SSU-2000e to a Subtending SSU, you must verify that the proper hardware is present, and you must install the appropriate software. The minimum software versions for the modules is listed in [Table 9-1](#).

Table 9-1. Minimum Software Versions for Subtending Operation

Module	Minimum Revision Level
Communications:	
Basic Load	D.00
Basic + NTP	B.00
Basic + SNMPv2	B.00
Basic + NTP + SNMPv2	B.00
Basic + NTP + SNMPv3	A.00
Clock (ST2 or ST3E)	C.00
Composite Clock Input	A.00
Composite Clock Output	PLD: B.00 S/W: B.00

Required Hardware

The Subtending SSU mode *requires* the following modules in the shelf:

- CC Input module and CC Output module or

All other available modules can be used in the Subtending SSU mode. The shelf must contain the appropriate Clock module(s), Communications module, and Input and Output modules.

Installing Software

The Subtending SSU requires the software listed in [Table 9-2](#):

Table 9-2. Files Required for Upgrading the Firmware

Item Number to be Upgraded	Description	File for Module Firmware Upgrade	File for Module PLD/FPGA Upgrade
23413012-000-0 23413012-001-0 23413012-002-0 23413012-003-0 23413012-004-0 23413012-005-0	Comms Module	01200D00.DN1 01201B00.DN1 01202B00.DN1 01203B00.DN1 01204B00.DN1 01205B00.DN1	SCOMFPGA.DN9
23413015-000-0	Stratum 3E Clock Module	01500C00.DN1	SCLKFPGA.DN9
23413016-000-0	Stratum 2 Clock Module	01500C00.DN1	SCLKFPGA.DN9
23413279-000-0	CC Input Module	27900A00.DN1	SSUCCINP.DN9
23413158-000-0	CC Output Module	15800B00.DN1	SSUCCOUT.DN9

To install the software you need to use either the SynCraft application or the SSU-2000 Download application

Using the SynCraft Application

To use the SynCraft application to install software, refer to the on-line documentation provided within the program.

Changing From Subtending SSU Mode

To change a Subtending SSU back to the normal mode:

1. Log in to the SSU-2000e and press **Enter**. The system prompt appears.
2. Type `opermode normal` and press **Enter**. The system responds with:

```
2002-08-15-T15:57:56Z ID: SSU2000 Name: SSU_2000e
The SSU2000e is in Normal Mode
```
3. Type `bye` and press **Enter** to log off.

No hardware changes are necessary.

SSU-2000e Configuration Chart

A fully-populated SSU-2000e main shelf is shown in [Figure 9-4](#). [Table 9-3](#) contains a listing of all SSU-2000e components, provides the associated Symmetricom part numbers and provides other configuration data required to procure a custom system.

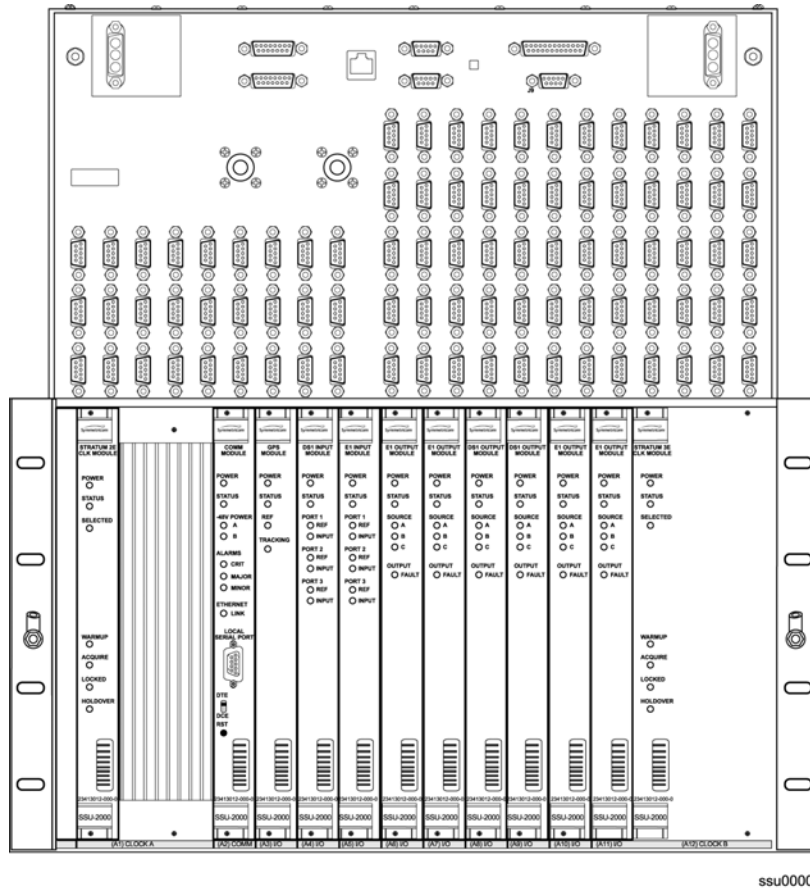

Figure 9-4. SSU-2000e Main Shelf, Front View

Table 9-3. SSU-2000e System Components

Item	Description	Part Number	Notes
SSU-2000e Main Shelf and Associated Hardware			
1	SSU-2000e Main Shelf (Chassis) with SDU termination plug and SSU-2000e Synchronization Supply Unit User Guide	25413140-000-0	Required for all systems. If an expansion chassis (SDU-2000e) is not attached to J8, an SSU Expansion Terminator, P/N 12013049-000-0 must be installed on the SSU-2000e chassis, connector J8. Otherwise, the terminator must be installed on the last expansion chassis in the system. Requires minimum of one Comms module, one Clock module, one Input module, one Output module, and eight filler panels (including one wide panel).
2	Bracket, rack ear, 530mm	00413140-001-1-2	Two each provided with the main shelf.
3	Bracket, rack ear, 480mm	00413140-000-1	Two each required per main shelf (must specify 23" rack).
Clock Modules			
4	Stratum 2E Rb Clock module	23413016-000-0	<ol style="list-style-type: none"> 1. Minimum of one Clock module per system (item 4, 5, or 6). 2. Redundant configuration with automatic switching in case of clock failure requires two Clock modules. 3. The system will operate with 2E, 3E, or Type I clocks combined. 2E clock should be installed in chassis slot A1.
5	3E Clock module	23413015-000-0	<ol style="list-style-type: none"> 1. Minimum of one Clock module per system (item 4, 5, or 6). 2. Redundant configuration with automatic switching in case of clock failure requires two Clock modules. 3. The system will operate with 2E, 3E, or Type I clocks combined. 2E clock should be installed in chassis slot A1.
6	Type I Clock module	23413015-001-0	<ol style="list-style-type: none"> 1. Minimum of one Clock module per system (item 4 or item 5). 2. Redundant configuration with automatic switching in case of clock failure requires two Clock modules. 3. The system will operate with 2E, 3E, or Type I clocks combined. 2E clock should be installed in chassis slot A1.

Table 9-3. SSU-2000e System Components (Continued)

Item	Description	Part Number	Notes
Communications Module			
7	Communications module	23413012-000-0	One required per SSU-2000e system.
Input Modules			
8	3-Port DS1 Input module	23413013-002-0	Accepts up to three DS1 or clock signals.
9	1-Port DS1 Input module	23413013-001-0	Accepts one DS1 or clock signal.
10	3-Port E1 Input module	23413014-002-0	Any combination of three G.703/9, G.703/13, or clock inputs.
11	1-Port E1 Input module	23413014-001-0	Any G.703/9, G.703/13, or clock input.
12	GPS Input module	23413019-000-0	One radio input signal
13	Composite Clock Input module	23413279-000-0	<ol style="list-style-type: none"> 1. Accepts one Composite Clock signal 2. Requires Composite Clock Input Adapter
14	Input signal terminator 120Ω (DS1)	5511021-0038	As required
15	Input signal terminator 100Ω (E1)	5511021-0039	As required
16	Input signal terminator 75Ω (Coaxial cable)	5511021-0041	As required
Output Modules			
17	E1 Output Module	23413018-000-0	<ol style="list-style-type: none"> 1. Minimum of 1 Output module required. 2. Each Output module provides 20 single output signals or 20 redundant signals (if desired) in even/odd slots.
18	DS1 Output Module	23413017-000-0	<ol style="list-style-type: none"> 1. Minimum of 1 Output module required. 2. Each Output module provides 20 single output signals or 20 redundant signals (if desired) in adjacent slots.
19	2048 kHz Output Module	23413159-000-0	<ol style="list-style-type: none"> 1. Installed in sets of two. 2. Each Output module pair provides 20 sets of summed output signals (redundant configuration). 3. Maximum of 6 redundant output modules can be installed in main shelf (60 summed outputs). 4. Applications requiring more than 60 output clocks require SDU-2000e Expansion Shelf (see Table 9-4).

Table 9-3. SSU-2000e System Components (Continued)

Item	Description	Part Number	Notes
20	Composite Clock Output Module	23413158-000-0	<ol style="list-style-type: none"> 1. Installed in sets of two. 2. Each Output module pair provides 20 sets of summed output signals (redundant configuration). 3. Maximum of 6 redundant output modules can be installed in main shelf (60 summed outputs). 4. Applications requiring more than 60 output clocks require SDU-2000e Expansion Shelf (see Table 9-4).
21	RS-422 (Select Rate) Module	23413287-000-0	<ol style="list-style-type: none"> 1. Installed in sets of two. 2. Each Output module pair provides 20 sets of summed output signals (redundant configuration). 3. Maximum of 6 redundant output modules can be installed in main shelf (60 summed outputs). 4. Applications requiring more than 60 output clocks require SDU-2000e Expansion Shelf (see Table 9-4).
22	E1/2048 Module	23413292-000-0	<ol style="list-style-type: none"> 1. Installed in sets of two. 2. Each Output module pair provides 20 sets of summed output signals (redundant configuration). 3. Maximum of 6 redundant output modules can be installed in main shelf (60 summed outputs). 4. Applications requiring more than 60 output clocks require SDU-2000e Expansion Shelf (see Table 9-4).
Adapter and Blank Filler Panels			
23	Adapter, 9-pin to wire-wrap	22013085-000-0	One DE9 I/O connector to wire wrap adapter for each DE9 I/O connector (optional).
24	Clock Module Filler Panel (8.1cm wide)	10913022-000-0	Filler panels are required in all unused clock slots.
25	Standard Module Filler Panel (1.5cm wide)	10913021-000-0	Filler panels are required in all unused SSU-2000e and SDU-2000e chassis slots. The 1.5cm panel fits all unused slots in Expansion Chassis and all except A1 and A12 (the two end slots) in the Main chassis.

SDU-2000e Configuration Chart

The SSU-2000e and SDU-2000e modular construction and the plug-and-play features allow the system to be available in a variety of telecommunications configurations. Adding one or more expansion chassis to a new or existing SSU-2000e system is a relatively simple process.

In this section, expansion chassis components and associated Symmetricom part numbers are provided to help with configuring an expansion system.

A fully-populated SDU-2000e expansion shelf is shown in [Figure 9-5](#). [Table 9-3](#) contains a listing of all SDU-2000e components and associated Symmetricom part numbers. This table also provides other configuration data required to design a custom system.

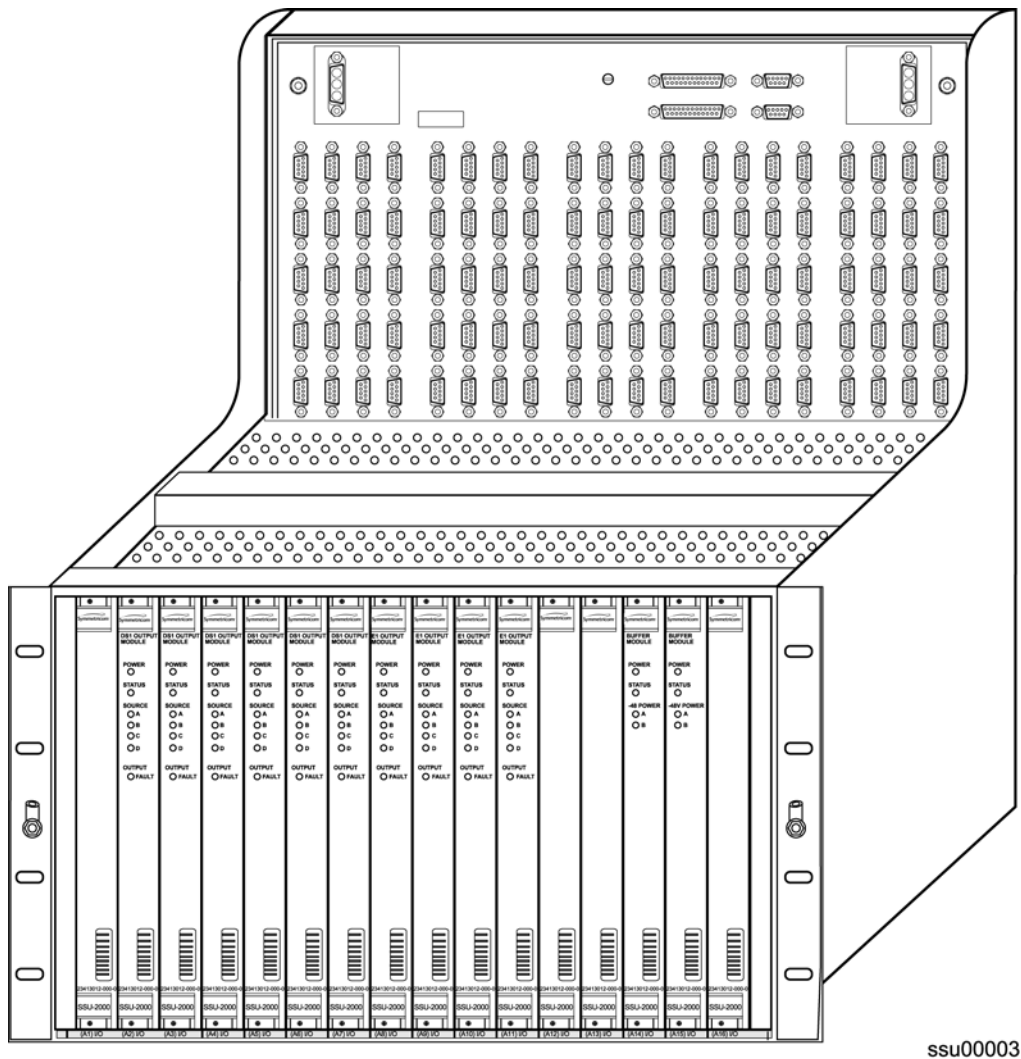

Figure 9-5. SDU-2000e Expansion Shelf, Front View

Table 9-4. SDU-2000e System Components

Item No.	Description	Symmetricom Part Number	Notes
SDU-2000e Expansion Shelf and Associated Hardware			
1	SDU-2000e Expansion Shelf (Chassis)	25413141-000-0	<ol style="list-style-type: none"> 1. Required for all expansion systems. 2. The SSU Expansion Terminator and SDU Backup Clock Terminator must be moved from the SSU-2000e chassis, connectors J8 and J9 to connectors J105 and J106, respectively, on the last expansion chassis in the daisy chain. 3. Requires minimum of one Buffer module (two required for redundancy) and one or more (maximum of ten) Output modules. 4. Unpopulated slots in the chassis require a filler panel.
Buffer Module			
2	Buffer Module	23413122-000-0	One minimum required per SDU-2000e expansion chassis; two required for robust configuration.
Output Modules			
3	E1 Output Module	23413018-000-0	<ol style="list-style-type: none"> 1. Installed in sets of two. 2. Each Output module pair provides 20 sets of summed Output signals (redundant configuration). 3. Maximum of 10 redundant Output modules can be installed in expansion shelf.
4	DS1 Output Module	23413017-000-0	<ol style="list-style-type: none"> 1. Installed in sets of two. 2. Each Output module pair provides 20 sets of summed output signals (redundant configuration). 3. Maximum of 10 10 redundant Output modules can be installed in expansion shelf.
5	2048 kHz Output Module	23413159-000-0	<ol style="list-style-type: none"> 1. Installed in sets of two. 2. Each Output module pair provides 20 sets of summed output signals (redundant configuration). 3. Maximum of 10 redundant Output modules can be installed in expansion shelf.

Table 9-4. SDU-2000e System Components (Continued)

Item No.	Description	Symmetricom Part Number	Notes
6	Composite Clock Output Module	23413158-000-0	<ol style="list-style-type: none"> 1. Installed in sets of two. 2. Each Output module pair provides 20 sets of summed output signals (redundant configuration). 3. Maximum of 10 redundant Output modules can be installed in expansion shelf.
7	E1/2048 kHz Output Module	23413292-000-0	<ol style="list-style-type: none"> 1. Installed in sets of two. 2. Each Output module pair provides 20 sets of summed output signals (redundant configuration). 3. Maximum of 10 redundant Output modules can be installed in expansion shelf.
Blank Filler Panels			
8	Standard Module Filler Panel (1.5cm wide)	10913021-000-0	Filler panels are required in all unused SDU-2000e chassis slots.
EIA-232 Cabling			
9	Cable, EIA-232 Shielded, DB9P to DB9S, 5 ft. (1.5 m)	551026-0038	Used for communication with the SSU-2000e.

Index

Numerics

- 1-Port DS1 Input module [42](#), [174](#)
- 1-Port E1 Input module [42](#), [164](#)
- 2048 kHz Output module [44](#), [213](#)
 - block diagram [216](#)
 - front panel [218](#)
 - LED indicators [217](#), [218](#)
 - Specifications [219](#)
 - specifications [219](#)
- 3-Port DS1 Input module [42](#), [174](#)
- 3-Port E1 Input module [42](#), [164](#)
- 3-sigma test [166](#), [176](#)

A

- access levels
 - adding a user [96](#)
 - adding the administrator [95](#)
 - overview [94](#)
- adding a module [106](#)
- adding a user, ICS procedure [96](#)
- address, IP
 - setting, example [92](#)
- address, shipping [142](#)
- addressing
 - expansion shelf [53](#)
- administrator
 - adding an administrator-level user [95](#)
- administrator user level [95](#)
- alarm
 - relay contacts, Communications module [36](#)
- Alarm Indication Signaling. See AIS
- alarm modes [30](#)
- alarms [176](#)
 - categories [36](#)
 - checking current [113](#)
 - connections [71](#)
 - connections, general [36](#)
 - connections, pin assignments [37](#)
 - critical [36](#)
 - hex digits [206](#), [214](#), [221](#)
 - input, reporting [169](#)
 - major [36](#)
 - minor [36](#)
 - MTIE [166](#)
- alarms and events [29](#)
- antenna
 - connections [33](#)
 - connections, general [38](#)
- architecture SSU-2000e [23](#)

- autoreturn [26](#)
- autoswitch [26](#)

B

- backing up a configuration [115](#)
- basic system load [46](#)
- Bipolar Violations. See BPV
- block diagram
 - 2048 kHz Output module [216](#)
 - CC Input module [189](#)
 - Communications module [158](#)
 - Composite Clock Output module [202](#)
 - DS1 Input module [175](#)
 - DS1 Output module [198](#)
 - E1 Input module [165](#)
 - E1 Output module [195](#)
 - E1/2048 kHz Output module [210](#)
 - GPS Input module [184](#)
 - RS-422 Output module [223](#)
 - SDU-2000e [50](#)
 - SSU-2000e [24](#)
 - Stratum 2E Clock module [145](#)
 - stratum 3E Clock module [149](#)
- Buffer module [44](#)
- buffered clocks [53](#)
- bypass clock [27](#)

C

- calculating MTIE [176](#)
- calculating TDEV [176](#)
- cautions defined [16](#)
- Cesium fault, DS1 Input module [179](#)
- changing mode [235](#)
- chassis slot assignments, SSU-2000e [32](#)
- checking current alarms [113](#)
- checklist
 - installation procedure [84](#)
 - pre-installation, SSU-2000e [58](#)
 - pre-installation, tools and materials [59](#)
 - system readiness [120](#)
- Clock
 - connection, backup [34](#)
 - connections, input [33](#), [67](#)
 - connections, output [35](#), [70](#)
 - output pin assignments [70](#)
 - output slots [70](#)
- clock
 - overview [28](#)
 - SDU backup [52](#)
- Clock C [27](#), [208](#)

- clock input connector pinout [68](#)
- clock input connectors [34](#)
- clock module section, SSU-2000e [28](#)
- Clock module STR 2E [144–147](#)
- Clock module STR 3E [148–151](#)
- clock output connector pinout [70](#)
- clock source [51](#)
- clocks
 - buffered [53](#)
- Commands
 - ICS see ICS commands
 - TL1 see TL1 commands
- communication
 - connections [33](#)
 - connections, general [39](#)
 - EIA-232 changes, procedure [65](#)
- communication interface
 - connections [63](#)
 - expansion shelf, procedure [70](#)
 - SDU-2000e, procedure [70](#)
- communication module section, SSU-2000e [28](#)
- communications
 - port assignments [90](#)
 - protocol [44](#)
 - requirements, input control [67](#)
 - requirements, output control [67](#)
- communications interface
 - setting up [63](#)
- Communications module [42](#), [156–162](#)
 - connections [66](#)
 - software loads [45](#)
 - software part numbers [46](#)
- communications module ports [28](#)
- communications ports [39](#)
- components
 - SDU chassis [52](#)
- Composite Clock Input module [188](#)
 - block diagram [189](#)
 - factory default settings [191](#)
 - front panel [190](#)
 - overview [43](#)
- Composite Clock Output module [43](#), [201](#), [204](#)
 - front panel [203](#)
- configuration
 - backing up [115](#)
 - changing defaults [113](#)
 - customizing options [114](#)
 - Ethernet port [92](#)
 - factory default [113](#)
 - hardware, mounting procedure [61](#)
 - monitor only [229](#)
 - monitor only illustration [23](#)
 - PRS illustration [22](#)
 - restoring [116](#)
 - restoring factory defaults [114](#)
 - SDU-2000e [240](#)
 - SSU-2000e [236](#)
 - TSG illustration [22](#)
- Configuration Settings [187](#)
- connections
 - alarm closure [36](#)
 - alarm status [33](#)
 - alarm, pin assignments [37](#)
 - antenna, general [38](#)
 - backup clock [34](#)
 - clock input signals [33](#)
 - clock input, procedure [67](#)
 - clock output, procedure [70](#)
 - communication interface [63](#)
 - communication ports [33](#)
 - communication, general [39](#)
 - DCE/DTE [65](#)
 - DTE/DCE [33](#)
 - east and west [35](#)
 - EIA-232, functional description [64](#)
 - EIA-232, pin assignments [39](#)
 - EIA-232, procedure [64](#)
 - Ethernet, pin assignments [66](#)
 - ethernet, pin assignments [40](#)
 - features, main shelf [33](#)
 - functional description [35](#)
 - ground, use of [38](#)
 - grounding lugs, rack [33](#)
 - groups, input [34](#)
 - input [35](#)
 - input group map [34](#)
 - input module references [34](#)
 - input power, procedure [63](#)
 - load [35](#)
 - main shelf [32](#)
 - monitoring [35](#)
 - normally closed [71](#)
 - normally open [71](#)
 - optional interface [34](#)
 - output module references [36](#)
 - power A label [62](#)
 - power B label [62](#)
 - power, general [37](#)
 - power, pin assignments [62](#)
 - procedure, ethernet [65](#)
 - slot references [34](#), [36](#)
- connector
 - J10-J36 [34](#)
 - J1-J2 [37](#)
 - J3-J5 [39](#)
 - J40-J99 [36](#)
 - J6-J7 [38](#)
- connector panel [54](#)
- connector pin assignment

- clock input [68](#)
- clock output [70](#)
- connectors
 - clock input [34](#)
 - expansion [55](#)
 - output clock [35](#)
- Control
 - overview [47](#)
- Cyclical Redundancy Check. See CRC

D

- damage
 - shipping [58](#)
- DCE/DTE
 - connections [33](#)
 - signal requirements [65](#)
- DDS see direct digital synthesis
- default configuration
 - restoring [114](#)
- Default settings
 - EIA-232 [64](#)
- Digital voltmeter [59](#)
- direct digital synthesis (DDS) [28](#)
- disabling a module, procedure [76](#)
- documentation, related [17](#)
- DS1
 - phase measurement averages [175](#)
- DS1 Input module [174](#), [180](#), [181](#)
 - alarm modes [177](#)
 - Cesium fault [179](#)
 - front panel [180](#)
- DS1 Output module [43](#), [198](#), [200](#)
- DS1/E1 Input modules [42](#)
- DTE/DCE
 - connections [33](#)
 - signal requirements [65](#)
 - switch settings [65](#)
- DTE/DCE switch, serial port [65](#)
- DVM see digital volt meter

E

- E1 Input module [164–171](#)
- E1 Input module Alarm Modes [167](#)
- E1 Input module Hardware Alarms [168](#)
- E1 Output module [43](#), [194](#), [197](#)
 - front panel [196](#)
- E1/2048 kHz Output module [43](#), [205](#)
 - block diagram [210](#)
 - front panel [211](#)
 - specifications [212](#)
- E1/DS1 Input modules [42](#)
- East
 - connections [35](#)
- EIA-232 [47](#)

- changes procedure, communication [65](#)
- connections, functional description [64](#)
- connections, pin assignments [39](#)
- connections, procedure [64](#)
- connector pin assignments [39](#)
- default settings [64](#)
- electromagnetic interference considerations [59](#)
- electrostatic discharge [74](#)
- EMI considerations [59](#)
- EMI precautions, considerations [59](#)
- equipment, returning [142](#)
- error counts, inputs [168](#)
- ESD see electrostatic discharge
- Ethernet
 - connections procedure [65](#)
 - connections, pin assignments [40](#), [66](#)
- Ethernet port [64](#)
 - assignment [90](#)
 - configuring [92](#)
 - connector [65](#)
 - protocol [90](#)
- event detection, modes [21](#)
- Events [180](#)
 - E1 Input module [170](#)
- events and alarms [29](#)
- exchanging a module, procedure [75](#)
- expansion connectors [55](#)
- expansion shelf
 - communication interface, procedure [70](#)
- expansion shelf addressing [53](#)

F

- fail mode [31](#)
- filler (blank) panel
 - clock [239](#)
 - standard [239](#)
- fire protection
 - fusing [60](#), [133](#)
- frequency
 - output, setting, RS-422 Output module [220](#)
- front panel
 - CC Input module [190](#)
 - CC Output module [203](#)
 - DS1 Input module [180](#)
 - E1 Output module [196](#)
 - E1/2048 kHz Output module [211](#)
 - RS-422 Output module [224](#)
- front view, SSU-2000e [20](#)
- functional description
 - connections [35](#)
 - EIA-232 connections [64](#)
 - output signal [36](#)
 - power [38](#)
- fuse replacement

warning [60](#), [133](#)

G

GPS antenna
 caution near high voltage lines [73](#)
 connections [33](#)

GPS Input module [184](#), [186](#), [187](#)
 overview [42](#)

graphical user interface [46](#)

ground
 DVM measurement, use of [62](#)
 precautions, considerations [62](#)
 rack connections [33](#), [38](#)

grounding [60](#), [73](#), [133](#)

Groups
 input map [34](#)

GUI. See graphical user interface

H

Hardware
 mounting procedure, configuration [61](#)

I

ICS
 overview [44](#)

idle-level users [95](#)

ignore mode [30](#)

indicators overview [47](#)

input
 communication requirements [67](#)
 connections [35](#)
 pin assignments, slots [69](#)
 termination, non-payload, E1/DS1 [68](#)
 through payload termination, E1/DS1 [69](#)

input connections [35](#)

Input modules
 connection references [34](#)

input reference
 overview [25](#)

input section, SSU-2000e [24](#)

Input selection mode [26](#)

inputs
 error counts [168](#)
 group maps [34](#)

inspecting
 procedure [58](#)

installation
 checklist, procedure [84](#)
 EMI considerations [59](#)
 modules, precautions [74](#)
 modules, procedure [73](#)
 procedure, general [60](#)
 procedure, main shelf [62](#)

 procedure, overview [57](#)
 SSU-2000e system [57](#)
 tools and materials [59](#)

installing modules [75](#)

interface connections, optional [34](#)

interference, electromagnetic [59](#)

L

LED Indicators [186](#)
 E1 Input module [170](#)

LED indicators [47](#), [56](#)
 2048 kHz Output module [217](#), [218](#)

LEDs
 CC Input module [190](#)
 CC Output module [203](#)
 DS1 Input module [180](#)
 E1 Output module [196](#)
 E1/2048 kHz Output module [211](#)
 RS-422 Output module [224](#)

load connections [35](#)

locked mode [47](#)

Loss of Signal. See LOS

M

main shelf
 communications ports [39](#)
 connection features [33](#)
 connections [32](#)
 connections, upper half [34](#)
 installation procedure [62](#)
 module assignments [31](#)
 power connections [37](#)

master controller function [28](#), [157](#)

modes
 alarm [30](#)
 fail [31](#)
 ignore [30](#)
 report [30](#)

module
 disabling, procedure [76](#)
 exchanging, procedure [75](#)
 removing, procedure [77](#)

module assignments [31](#)

modules
 2048 kHz Output module [213](#)
 2E Clock module [41](#)
 adding or enabling [106](#)
 Buffer [44](#)
 CC Output module [201](#)
 Clock module STR 2E [144–147](#)
 Clock module STR 3E [148–151](#)
 Communication module, configuration data [161](#)
 Communications module [42](#), [152](#), [156–162](#)

Composite Clock Input [43](#), [188](#)
 Composite Clock Output [43](#)
 Composite Clock Output module [204](#)
 composite clock output module, specifications [204](#)
 disabling [107](#)
 DS1 Input module [42](#), [174](#), [181](#)
 DS1 Input module, factory defaults [182](#)
 DS1 Output [43](#)
 DS1 Output module [198](#), [200](#)
 DS1 output module [198](#)
 DS1 output module, block diagram [198](#)
 DS1 output module, status LEDs [199](#)
 E1 Input module [42](#), [164–171](#)
 E1 Input module, configuration data [172](#)
 E1 input module, configuration data [182](#)
 E1 input module, factory defaults [172](#)
 E1 Input module, software options [172](#)
 E1 Output module [43](#), [194](#), [197](#)
 GPS Input module [42](#), [184](#), [186](#)
 installation precautions [74](#)
 installation, procedure [73](#)
 installing, procedure [75](#)
 overview [40](#)
 removing [107](#)
 RS-422 Output [44](#)
 Stratum 3E Clock module [41](#)
 Type 1 Clock [41](#)
 monitoring connections [35](#)
 monitor-only configuration [23](#)
 mounting
 procedure, system hardware [61](#)
 MTIE [176](#)
 alarms [176](#)
 calculation [176](#)
 MTIE Calculation [166](#)

N

NC normally closed connections [71](#)
 NO normally open connections [71](#)
 non-revertive mode [26](#)
 normal mode
 changing to [235](#)
 notes defined [16](#)
 NTP [45](#)

O

Operation
 overview [47](#)
 OPERMODE command [233](#)
 Out of Frame. See OOF
 output
 communications requirements [67](#)
 connections, clock [35](#)

output clock connectors [35](#)
 Output module
 connection references [36](#)
 output module section, SSU-2000e [27](#)
 output signal
 connections [33](#)
 functional description [36](#)
 outputs
 failed, identifying [207](#), [215](#)
 RS-422 Output module, frequency [220](#)
 squenching, 2048 kHz Output module [213](#)
 squenching, E1/2048 kHz Output module [205](#)
 squenching, RS-422 Output module [220](#)
 overview
 indicators and control [47](#)
 installation procedure [57](#)
 operation [47](#)

P

packaging for shipment [141](#)
 parts, reordering [141](#)
 password requirements [94](#), [96](#)
 performance
 SSU-2000e specifications [21](#)
 phase buildout, description [165](#)
 phase zeroing [167](#)
 pin assignments
 alarm connection [37](#)
 EIA-232, serial port [39](#)
 ethernet [40](#)
 Ethernet connections [66](#)
 input, slots [69](#)
 output, slots [70](#)
 power connections [62](#)
 pinouts
 serial port [39](#)
 ports
 communications module [28](#)
 power
 connections [33](#)
 connections, general [37](#)
 connections, pin assignments [62](#)
 functional description [38](#)
 input and grounding [54](#)
 input connections, procedure [63](#)
 Power A connections, label [62](#)
 Power B connections, label [62](#)
 power connections
 main shelf [37](#)
 power-up [47](#)
 PQL
 and squelching outputs [205](#), [213](#)
 Precautions
 module installation [74](#)
 ventilation considerations [60](#)

precautions
 grounding considerations [62](#)

pre-installation
 procedure, checklist [58](#)

primary reference source configuration [22](#)

Priority level [25](#)

priority mode
 overview [26](#)

Procedure
 clock input connections [67](#)
 clock output connections [70](#)
 EIA-232 connections [64](#)
 expansion shelf, communication interface [70](#)
 installation checklist [84](#)
 installation, general [60](#)
 module installation [73](#)
 SDU-2000e, communication interface [70](#)
 unpacking [58](#)

procedure
 EIA-232 changes, communication [65](#)
 inspecting [58](#)
 installation, main shelf [62](#)
 mounting, system hardware [61](#)
 power input connections [63](#)
 pre-installation, SSU-2000e [58](#)

product overview, SSU-2000e [19](#)

protocol, communications [44](#)

provisioning
 general parameters, ICS and TL1 examples [105](#)
 GPS Input modules, ICS and TL1 examples [108](#)
 Other Input modules, ICS and TL1 examples [109](#)
 Output modules, ICS and TL1 examples [111](#)
 saving the setup [112](#)

PRS configuration [22](#)

PRS configuration Illustration [22](#)

R

readiness
 checklist, system [120](#)

recommendations defined [16](#)

Reference switching [26](#)

related documentation [17](#)

removing a module, procedure [77](#)

reordering parts [141](#)

repacking [141](#)

repacking equipment [141](#)

report mode [30](#)

reporting input alarms [169](#)

requirements
 communication control, input/output [67](#)
 terminator, SSU expansion [71](#)

restoring a configuration [116](#)

Return Authorization [142](#)

returning equipment [141](#)

revertive mode [26](#)

RMA number see returning equipment

RS-422 Output module [44](#)
 block diagram [223](#)
 front panel [224](#)
 specifications [225](#)

rubidium oscillator [41](#)

S

SDU
 chassis components [52](#)

SDU backup clock [52](#)

SDU-2000e
 communication interface, procedure [70](#)
 setting address [53](#)
 specifications [56](#)
 synchronization distribution unit [48](#)

security
 overview [93](#)

security log [94](#)

security system
 user levels

selecting the system reference [26](#)

serial port [64](#)
 assignment [90](#)
 pin assignments [39](#)
 protocol [90](#)

serial port pinouts [39](#)

shipping
 containers [141](#)

shipping address [142](#)

signal requirements
 DCE/DTE [65](#)

Simple Network Management Protocol. See SNMP slots
 connection references [34](#), [36](#)
 input pin assignments [69](#)
 output, pin assignments [70](#)

SNMP
 overview [45](#)

software
 versions [45](#)

Software OptionsDS1 Input module [182](#)

specifications
 2048 kHz Output module [219](#)
 E1/2048 kHz Output module [212](#)
 RS-422 Output module [225](#)

squelch
 2048 kHz Output module [213](#)
 E1/2048 kHz Output module [205](#)
 RS-422 Output module [220](#)

SSM [167](#), [177](#)

SSM Selection Criteria [167](#)

SSM, Synchronization Status Messages [25](#)

SSU-2000e

- architecture [23](#)
- block diagram [24](#)
- clock module section [28](#)
- communication module section [28](#)
- connections [32](#)
- connections, upper half [34](#)
- front view [20](#)
- input section [24](#)
- installation [57](#)
- installation procedure [62](#)
- main shelf [31](#)
- modules [40](#)
- output module section [27](#)
- system [20](#)
- system components [31](#)
- status indicators
 - 2048 KHz Output module [218](#)
 - Composite Clock Input module [190](#)
 - E1 Output module [196](#)
- Stratum 2E Clock module [41](#)
- Stratum 3E Clock module [41](#)
- structure of this guide [15](#)
- subtending mode
 - setting, procedure [234](#)
- summed pair [49](#)
- supervisor-level users [95](#)
- sync status messages [167](#)
- Synchronization Status Messages,SSM [25](#)
- Synchronization Status Messaging [21](#), [177](#)
- Syncraft [46](#)
- system components [31](#)
- system configurations [21](#)
- system hardware, mounting procedure [61](#)
- system load
 - basic [46](#)
- system modules [31](#)
- system readiness checklist [120](#)
- system reference, selecting [26](#)

T

- TDEV [166](#), [176](#)
 - calculation [166](#), [176](#)
- technician-level users [95](#)
- Telcordia Technologies (formerly Bellcore)
 - GR-1244 [26](#)
 - GR-378 [26](#)
- Telnet ports. See Ethernet port

- termination
 - input through payload, E1/DS1 [69](#)
 - non-payload input, E1/DS1 [68](#)
- termination plugs [51](#)
- terminator
 - requirements, SSU expansion [71](#)
- Three-Sigma Test [166](#)
- three-sigma test [166](#)
- TL1
 - overview [44](#)
- tools and materials
 - system installation [59](#)
- troubleshooting [133](#)
- TSG configuration [22](#)
- Type 1 Clock module [41](#)
 - block diagram [153](#)
 - functional overview [152](#)

U

- unpacking [58](#)
- unpacking and inspection [58](#)
- use of
 - DVM, ground measurement [62](#)
 - ground, integrated environment [38](#)
 - grounding lugs, rack [33](#)
- user
 - access levels [94](#)
 - adding, ICS [96](#)
- user access levels
 - adding a user [96](#)
 - adding the administrator [95](#)
- user access levels. see security system
- user-level users [95](#)

V

- ventilation precautions, considerations [60](#)

W

- warnings defined [16](#)
- web address [18](#)
- West connections [35](#)

Z

- zeroing phase [167](#)

